

BELMONT RESIDENCES AT CORAL GABLES

BEING A REPLAT OF LOTS 12 TO 31, A PORTION OF LOTS 11 AND 32, AND A PORTION OF THE 30 FOOT PLATTED ALLEY, ALL WITHIN BLOCK 3, REVISED PLAT CORAL GABLES INDUSTRIAL SECTION, RECORDED IN PLAT BOOK 28, PAGE 22, PUBLIC RECORDS OF MIAMI-DADE COUNTY, FLORIDA. LYING AND BEING IN THE NORTHEAST 1/4 OF SECTION 20, TOWNSHIP 54 SOUTH, RANGE 41 EAST, CITY OF CORAL GABLES, MIAMI-DADE COUNTY, FLORIDA.

PLAT BOOK _____

PAGE _____

SHEET 3 OF 3 SHEETS

PREPARED BY:

SSA SCHWEBKE SHISKIN + ASSOCIATES

LAND PLANNERS ENGINEERS LAND SURVEYORS
 BUSINESS LICENSE NO. LB # 87
 3240 CORPORATE WAY, MIRAMAR, FLORIDA 33025 TEL: (954)435-7010 FAX: (954)438-3288 DADE: (305)652-7010 FAX: (305)652-8284
 ORDER NO. 211400 MARCH, 2021

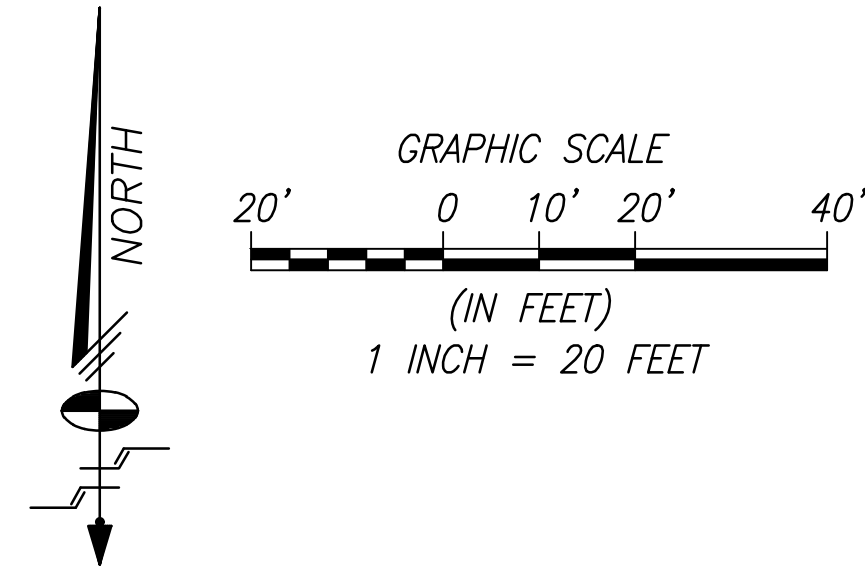

SURVEYOR'S NOTES:

THE BEARINGS SHOWN HEREON RELATE TO AN ASSUMED BEARING OF N88°09'42"W ALONG THE NORTH RIGHT-OF-WAY LINE OF AVENUE ALTARA BETWEEN SALZEDO STREET AND AURORA STREET.

- P.C.P. • DENOTES PERMANENT CONTROL POINT
- P.R.M. ⊙ DENOTES PERMANENT REFERENCE MONUMENT
- ⊕ DENOTES CENTERLINE
- P.B. DENOTES PLAT BOOK
- PG. DENOTES PAGE
- O.R.B. DENOTES OFFICIAL RECORDS BOOK
- T54S-R41E DENOTES TOWNSHIP 54 SOUTH-RANGE 41 EAST
- (R) DENOTES RECORD INFORMATION
- ± DENOTES MORE OR LESS
- ⊕ DENOTES SECTION CORNER

THE LANDS SHOWN HEREON ARE SUBJECT TO THE FOLLOWING INSTRUMENTS RECORDED IN THE PUBLIC RECORDS OF MIAMI-DADE COUNTY, FLORIDA, AS MAY BE AMENDED:

- DEED BOOK 3416, PAGE 94
- OFFICIAL RECORDS BOOK 31451, PG. 911
- DEED BOOK 1304, PAGE 9
- (a) DEED BOOK 839, PAGE 106, DEED BOOK 506, PAGE 37
- (b) DEED BOOK 939, PAGE 435, DEED BOOK 1004, PAGE 496
- (c) DEED BOOK 939, PAGE 443, DEED BOOK 1004, PAGE 499
- OFFICIAL RECORDS BOOK 10966, PAGE 1275
- OFFICIAL RECORDS BOOK 12066, PAGE 1838
- OFFICIAL RECORDS BOOK 18872, PAGE 1985
- OFFICIAL RECORDS BOOK 20575, PAGE 1753
- OFFICIAL RECORDS BOOK 12670, PAGE 1223
- OFFICIAL RECORDS BOOK 12786, PAGE 903
- OFFICIAL RECORDS BOOK 13476, PAGE 3245
- OFFICIAL RECORDS BOOK 27196, PAGE 2990
- OFFICIAL RECORDS BOOK 27373, PAGE 3568
- OFFICIAL RECORDS BOOK 27853, PAGE 1707
- OFFICIAL RECORDS BOOK 28252, PAGE 220
- OFFICIAL RECORDS BOOK 28252, PAGE 244
- OFFICIAL RECORDS BOOK 31451, PAGE 911
- OFFICIAL RECORDS BOOK 32798, PAGE 3180

NOTICE: THIS PLAT, AS RECORDED IN ITS GRAPHIC FORM, IS THE OFFICIAL DEPICTION OF THE SUBDIVIDED LANDS DESCRIBED HEREIN AND WILL IN NO CIRCUMSTANCES BE SUPPLANTED IN AUTHORITY BY ANY OTHER GRAPHIC OR DIGITAL FORM OF THE PLAT. THERE MAY BE ADDITIONAL RESTRICTIONS THAT ARE NOT RECORDED ON THIS PLAT THAT MAY BE FOUND IN THE PUBLIC RECORDS OF THIS COUNTY.

RECORDING STATEMENT:

FILED FOR RECORD THIS _____ DAY OF _____ A.D., 20____, AT _____ M., IN BOOK _____ OF PLATS, AT PAGE _____ OF THE PUBLIC RECORDS OF MIAMI-DADE COUNTY, FLORIDA. THIS PLAT COMPLIES WITH THE LAWS OF THE STATE OF FLORIDA AND MIAMI-DADE COUNTY, FLORIDA.

ATTEST: HARVEY RUVIN
 CLERK OF THE CIRCUIT COURT

BY: _____ DEPUTY CLERK

