



City of Coral Gables Planning and Zoning Staff Report

Property:	141 Grand Avenue
Applicant:	Spark Learning, Inc., DBA Spark Learning XIV
Application:	Conditional Use – School in MX1
Public Hearing:	Planning and Zoning Board
Date & Time:	October 11, 2023; 6:00 – 9:00 p.m.
Location:	City Commission Chambers, City Hall, 405 Biltmore Way, Coral Gables, Florida 33134

1. APPLICATION REQUEST

The application request is for conditional use review of a proposed school located at 141 Grand Avenue. The Resolution under consideration is as follows:

A Resolution of the City Commission of Coral Gables, Florida granting conditional use approval pursuant to Zoning Code Article 14, "Process," Section 14-203, "Conditional Uses" for a School on a property zoned as Mixed-Use-1 (MX1) located at 141 Grand Avenue, Coral Gables, Florida; providing for a repealer provision, severability clause, and an effective date.

An application for conditional use review of a school in a Mixed-Use 1 District is subject to review and recommendation by the Planning and Zoning Board at one (1) public hearing, and consideration by the City Commission at one (1) public hearing (Resolution format).

2. APPLICATION SUMMARY

A conditional use application has been submitted by Mr. Edward Baker, Esq. of Berger Singerman LLP on behalf of Spark Learning, Inc., DBA Spark Learning XIV (the "Applicant") to the City of Coral Gables for a proposed private school on a property zoned as Mixed-Use 1 (MX1). Per Section 3-101 of the Zoning Code, a school is a conditional use in Mixed-Use 1 Districts.

The proposed school, referred as Spark Learning, will serve 35 students ranging from the third to eighth grade between the hours of 8:00 a.m. and 3:00 p.m. Monday through Friday. These students will take virtual core classes with Primer Microschool teachers who are experts in their subject field. Students will be supervised and assisted by an educator who has prior professional experience as a teacher or homeschooler. The students will also have the opportunity to work individually and collaboratively on projects that help achieve their personal goals and build critical thinking and artistic skills.

The subject property is approximately 5,224 square feet (0.12 acres). It is located south of US-1 and north of Grand Avenue between Jefferson Street and Brooker Street at 141 Grand Avenue within MacFarlane Homestead. It is surrounded by single-family residences and mixed-use 1 zoned properties. South of the property and across Grand Avenue is George W Carver Elementary and Middle School, inside City limits.

The property is zoned as Mixed-Use 1 (MX1) and has a future land use designation of Commercial Low-Rise Intensity. The site has an existing 1-story office building, where the top floor is a mezzanine, that comprises 2,634 square feet. The Applicant seeks to utilize the existing office building and only make minor modifications to the exterior and interior of the building. These alterations aim to improve the site and to accommodate a learning space. The Applicant plans to increase the concrete wall at the rear of the property, which abuts a single-family residence, to be 6 feet to comply with the Zoning Code. Section 5-403.G. states where residential and commercial districts adjoin each other, a 6 foot high wall must be constructed along the property line between the commercial and residential properties. The wall must be constructed and maintained by the commercial property owner. Additionally, the Applicant is adding a crosswalk crossing Grand Avenue, supplying a bike rack, providing landscape design elements, such as planting shrubs and shade trees, as well as reconfiguring the rear parking lot to provide pick up and drop off accommodations for students and parents/guardians.

Location map and aerial shown below:

Lot, Subdivision, and Plat Map

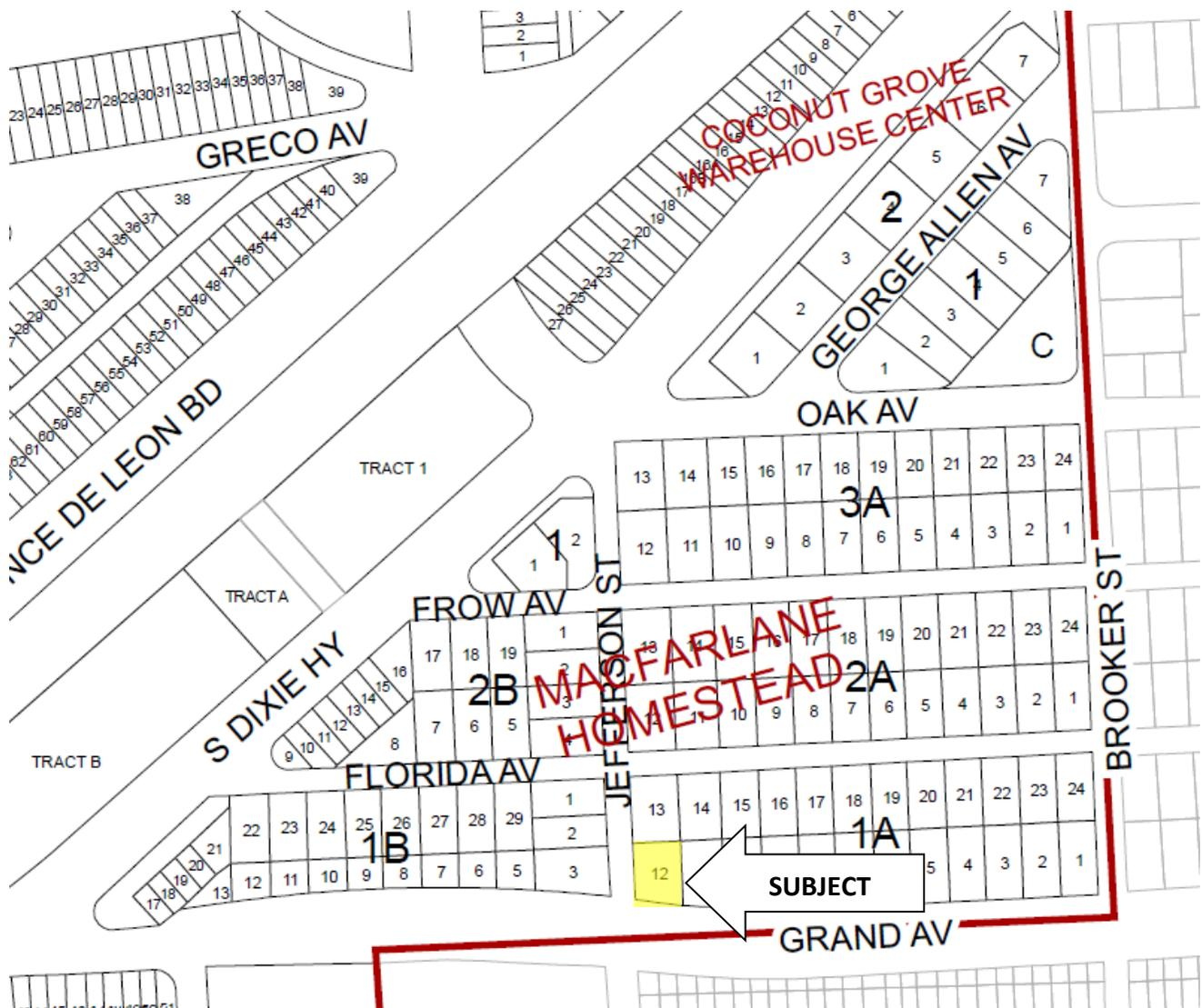

Aerial Map



Property Designations and Surrounding Uses

The following tables provide the subject property’s designations and surrounding land uses:

Existing Property Designations

Comprehensive Plan Future Land Use Map designation	Commercial Low-Rise Intensity
Zoning Map designation	Mixed-Use (1)

Surrounding Land Uses

Location	Existing Land Uses	CP Designations	Zoning Designations
North	Residential	Single-Family Low Density	Single-Family Residential (SFR)
Southwest (City of Miami)	Civic	Major Institution, Public Facilities, and Educational use	Parks and Recreation
West	Commercial	Commercial Low Rise Intensity	Mixed-Use 1 (MX1)
East	Other	Commercial Low Rise Intensity	Mixed-Use 1 (MX1)

The subject property currently has the existing land use and zoning designations, as illustrated in the following maps:

Future Land Use Map

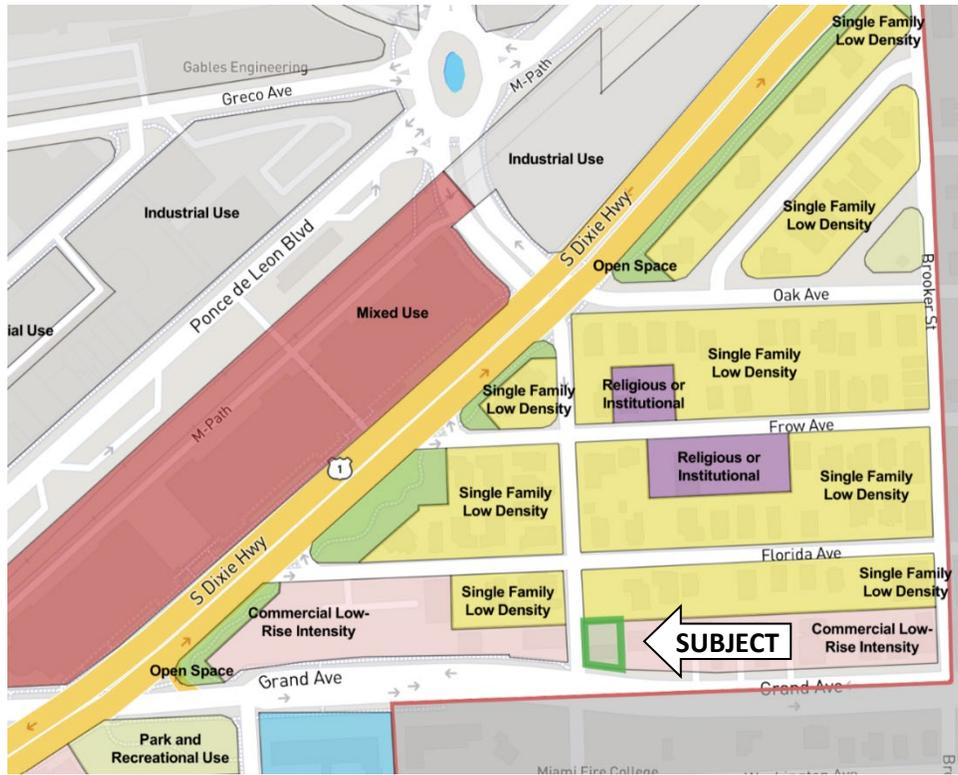

Existing Zoning Map

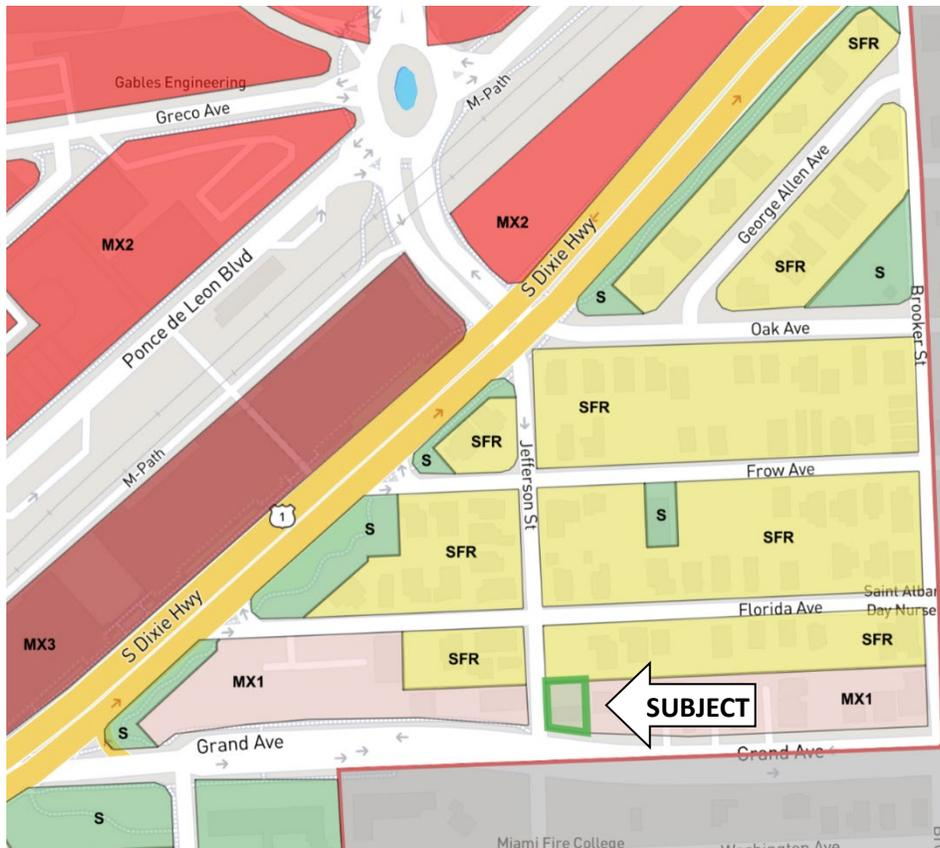

3. FINDINGS OF FACT

This section of the report presents City Staff’s evaluation of the Application and Findings of Facts for Conditional Use Site Plan review. The City’s responsibility is to review the Application for consistency with the City’s Comprehensive Plan Goals, Objectives and Policies and compliance with the Zoning Code and City Code.

To provide an overview of the purpose and intent of the Conditional Use provisions, Zoning Code Section 14-203, “Purpose and Applicability” provides for the following:

“The purpose of providing for conditional uses within each zoning district is to recognize that there are uses which may have beneficial effects and serve important public interests, but which may, but not necessarily, have adverse effects on the environment, particularly residential areas, overburden public services, or change the desired character of an area. Individualized review of these uses is necessary due to the potential individual or cumulative impacts that they may have on the surrounding area or neighborhood. The review process allows the imposition of conditions to mitigate identified concerns or to deny the use if concerns cannot be resolved.”

A Conditional Use review must comply with Zoning Code Section 14-203.8, “Standards for Review” as follows:

STANDARD	STAFF EVALUATION
A. The proposed conditional use is consistent with and furthers the goals, objectives and policies of the Comprehensive Land Use Plan and furthers the purposes of these regulations and other City ordinances and actions designed to implement the Plan.	<p>The proposed private school is consistent with and further the goals, objectives, and policies of the Comprehensive Plan. The proposed school adds another educational opportunity in the vicinity and City. Parents and students will benefit from its accessibility and small school environment.</p> <p>The school is particularly valuable for students who are interested in taking virtual classes but need a dedicated workspace and social environment. The school is utilizing Armbrister Park across the street for recreational open space, which the Applicant obtained a permit from the City of Miami. Parents will benefit from enrolling their children at Spark Learning, which offers a supervised space for their students to learn throughout the day. Therefore, a conditional use approval for the proposed school will offer students the opportunity and benefits of education.</p> <p>The exterior modifications improve the existing site conditions, such as increasing the existing concrete wall to 6 feet at the rear of the property and adding a crosswalk, bike rack, and landscaping in the private property and public right-of-way.</p>
B. The available use to which the property may be put is appropriate to the property that is subject to the proposed conditional use and compatible with existing and planned uses in the area.	The proposed school is appropriate for this Mixed-Use 1 District and its surrounding uses that are primarily single-family residences and mixed uses. Additionally, another school, GW Carver Elementary and Middle School, is located southwest of the property, across Grand Avenue. Although the existing structure is being utilized as an office, there is sufficient space to accommodate 35 students with interior

STANDARD	STAFF EVALUATION
	<p>arrangements. Staff’s recommended conditions of approval ensure Police enforcement of the proposed drop-off and pick-up school operations.</p>
<p>C. The proposed conditional use does not conflict with the needs and character of the neighborhood and the City.</p>	<p>The needs and character of the area will not be compromised by approving the proposed school in this Mixed-Use 1 zoned district. Existing and future residents will benefit from having another school in the area, particularly for students that seek a small school setting, virtual core classes, and engagement with other students. The parents/guardians of the students will also benefit by having a space to leave their children while they are working. Lastly, the proposed condition to require Police enforcement of the school’s traffic operations will ensure that the needs and character of the neighborhood are not impacted.</p>
<p>D. The proposed conditional use will not adversely or unreasonably affect the use of other property in the area.</p>	<p>The Applicant’s proposal will not adversely or unreasonably affect the use of other neighboring properties surrounding the site. The Applicant estimates there will be 35 students enrolled in the school and operate Monday through Friday from 8:00 a.m. to 3:00 p.m. The proposed school will only generate 32 trip-generation estimates during AM peak-hour trips according to the trip generation letter prepared by Vala Group, Inc. School zones times are already in place, from 7:30 a.m. to 9:15 a.m. and from 1:45 p.m. to 4:15 p.m.</p> <p>The proposed school will not have timeframe accommodations since all students, due to the small enrollment, will start school at the same time, being 8 a.m. Furthermore, the Applicant agreed to work with the County to mount pavement markings and traffic control devices for a school zone extension on Grand Avenue.</p> <p>Additionally, the Spark Learning should not be a nuisance to single-family residences neighboring the site. The rear of the property does not have open space for students to socialize loudly, and has the parking lot, concrete wall and vegetation that serve as buffers.</p> <p>Lastly, Staff is recommending Police enforcement of the Applicant’s proposed traffic operations so that the school use will not adversely or unreasonably affect the neighborhood.</p>
<p>E. The proposed use is compatible with the nature, condition and development of adjacent uses, buildings and structures and will not adversely affect the adjacent uses, buildings or structures</p>	<p>As aforementioned, the proposed school is compatible with the nature, condition, and development of adjacent uses, buildings, and structures in the area, which are single-family residences, retail, office, and a school. Immediately southwest of Grand Avenue is GW Elementary and Middle School. Establishing Spark Learning, a small school, in the area may attract more families to the neighborhood,</p>

STANDARD	STAFF EVALUATION
	boost the local economy, and offer better access to other educational resources.
F. The parcel proposed for development is adequate in size and shape to accommodate all development features.	The project site sits on Lot 12 of Block 1A within MacFarlane Homestead, and is approximately 5,224 square feet in size. The project is utilizing the existing building. Remodeling the interior space will accommodate the small 35 student population taking classes within the building. No addition to the existing structure is proposed.
G. The nature of the proposed development is not detrimental to the health, safety and general welfare of the community.	The proposed request for a school is not detrimental to the health, safety, and general welfare of the community. Adding this school can provide an array of opportunities for the neighborhood such as economic development and educational access for residents in the area and in the City of Coral Gables.
H. The design of the proposed driveways, circulation patterns and parking is well defined to promote vehicular and pedestrian circulation.	<p>The Applicant submitted a “Trip Generation Analysis” prepared by Vala Group, Inc., dated September 7, 2023, provides an analysis of the current traffic conditions and field observations regarding the traffic circulation for the student drop off and pick up operations (See Attachment A).</p> <p>Drop off and Pick up Operations</p> <p>Vehicular circulation and access to the school is provided by a driveway on Jefferson Street. Pedestrians can access the school through its main entrance. The Applicant is not providing bus services to transport students to the school.</p> <p>The Applicant has coordinated with 213/215 Grand Avenue (Offsite Area A) and 127 Grand Avenue (Offsite B) in a parking agreement at two off-site properties. Staff and teachers are assigned to park at Offsite A, which is west of the property. Meanwhile parents/guardians and student drop off and pick up are allotted to park on-site and at Offsite B that is east of the site. Students are not permitted to walk or ride a bike alone to and from school per County rules. Parents/guardians must walk their children to and from school. The Applicant states there will be a staggered schedule for drop-off and pick up times, between 7 a.m. and 8 a.m., and 3 p.m. and 4 p.m. Parents/guardians will have a 10-minute timeframe to drop off and pick up their children in the morning and afternoon.</p>
I. The proposed conditional use satisfies the concurrency standards of Section 14-218 and will not adversely burden public facilities,	A trip generation letter was prepared by Vala Group, Inc. According to the letter, the proposed school will generate less than 50 vehicle trips, and therefore, would not require a Traffic Impact Study.

STANDARD	STAFF EVALUATION
including the traffic-carrying capacities of streets, in an unreasonable or disproportionate manner.	

Staff's Findings: Based upon the Findings of Facts provided herein, Staff finds the Application satisfies the provisions of the Zoning Code for the Conditional Use of the proposed school in a Mixed-Use 1 zoned property. Staff review finds that the proposed plans and Staff's recommended conditions of approval incorporate measures to mitigate potentially negative impacts that could have adverse effects on neighboring properties.

Consistency Evaluation of the Comprehensive Plan (CP) Goals, Objectives and Policies

The Planning and Zoning Division has reviewed the CP and finds the following CP Goals, Objectives and Policies are applicable. Consistent CP Goals & Objectives and Policies are as follows:

Ref. No.	CP Goal, Objective and Policy	Basis for Consistency
1.	Goal FLU-1. Protect, strengthen, and enhance the City of Coral Gables as a vibrant community ensuring that its neighborhoods, business opportunities, shopping, employment centers, cultural activities, historic value, desirable housing, open spaces, and natural resources make the City a very desirable place to work, live and play.	Complies
2.	OBJECTIVE FLU-1.9: Encourage sound innovation in the development standards of the City's Zoning Code which provides a continuing process to respond to community needs.	Complies
3.	POLICY FLU-1.11.1: Maintain and enforce effective development and maintenance regulations through site plan review, code enforcement, and design review boards and committees.	Complies
4.	Policy FLU-1.14.1. The City shall enforce Zoning Code provisions which continue to address the location and extent of residential and non-residential land uses consistent with the Future Land Use Map in order to preserve the character of existing neighborhoods.	Complies
5.	Objective FLU-1.17. The City acknowledges the need to locate schools proximate to urban residential areas and, where possible, collocate public facilities, such as parks, libraries and community centers with schools.	Complies
6.	Goal FLU-3. The City as a part of its development review process shall engage public/community participation and collaboration to provide for a transparent development review process.	Complies
7.	Objective FLU-3.1. The City shall continue its efforts to notify stakeholders, residents, property owners and neighborhood associations of pending development reviews to provide transparency within the development process.	Complies

Staff Comments: Staff's determination that this Application is "consistent" with the CP's goals, objectives and policies. The proposed school as a conditional use fulfills Goal FLU-1., Objective FLU-1.9., Policy FLU-1.14.1., and Objective FLU-1.17. of the Comprehensive Plan. Spark Learning aims to protect, strengthen, and enhance the area for surrounding residents. Spark Learning, which offers a small school environment, virtual learning for core classes, and projects for personal goals, will increase educational resources and accessibility for students and parents in the vicinity and in the City.

The request also meets Policy FLU-1.11.1. This application, which provides a site plan, will not cause major impact to the adjacent properties. There will be no expansion or addition to the existing building nor any exterior modifications under this Application. The interior and exterior adjustments are intended to make the space an educational setting appropriate for its Staff and students. The Applicant will provide improvements to the site as advised by several City Departments, as well as the Miami-Dade County Department of Transportation and Public Works, to mitigate any concerns.

4. REVIEW TIMELINE AND PUBLIC NOTIFICATION

City Review Timeline

The submitted application has undergone the following City reviews:

Type of Review	Date
Development Review Committee	04.28.23
Board of Architects	07.27.23
Planning and Zoning Board	10.11.23
City Commission	TBD

Department	DRC 04.28.23	Board of Architects 07.27.23	Comments Provided
Historical Resources and Cultural Arts	X		Y
Art in Public Places	X		N
Parking	X		Y
Police	X		Y
Fire	X		Y
Public Works (Engineering)	X		Y
Public Works (Utilities)	X		Y
Zoning	X		N
Planning	X		Y
Board of Architects	X	X	Y
Building	X		Y
Greenspace Management	X		Y

Public Notification

The Applicant completed the mandatory neighborhood meeting with notification to all property owners within 1,000 feet of the property boundary on August 18th, 2023. The Zoning Code requires that a courtesy notification be provided to all property owners within 1,000 feet of the boundary of the property. The notice indicates: Application filed; public hearing dates/time/location; where the application files can be reviewed and provides for an opportunity to submit comments. Approximately 244 notices were mailed.

Courtesy Notification Radius Map

1,000' RADIUS MAP (N.T.S.)

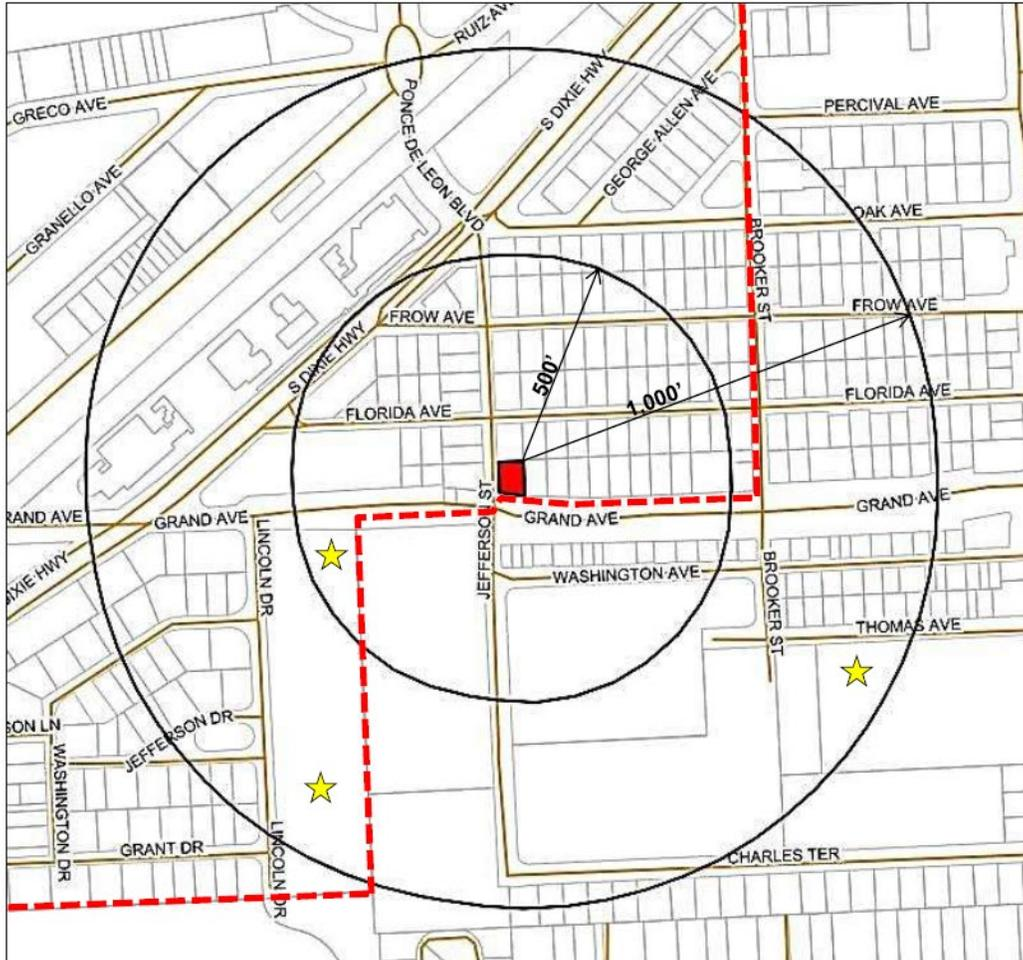

SUBJECT: 141 Grand Avenue, Coral Gables, FL 33133
FOLIO NUMBER: 03-4120-006-0950

LEGEND, IF APPLICABLE:
 CITY OF CORAL GABLES BOUNDARY - - - - - MDCPS ★

The following has been completed to solicit input and provide notice of the application
Public Notice

Type	Date
Applicant's Neighborhood Meeting	08.18.23
Sign posting of property	09.27.23
Mailed Notification for PZB Meeting - 1,000 feet	09.27.23
Legal advertisement	09.29.23
Posted Staff Report on City web page	10.06.23

5. STAFF RECOMMENDATION

The Planning and Zoning Division based upon the complete Findings of Fact contained within this Staff Report recommends approval, with conditions of the Applicant's request.

Conditions of Approval

Planning and Zoning Division Staff recommends the application be recommended for approval by the Board subject to the following conditions of approval:

1. **Student enrollment.** Student enrollment at Spark Learning shall be limited to a maximum of 35 students from grades 3 through 8.
2. **Hours of Operation.** Classes shall only be held on Monday through Friday, between 8:00 a.m. and 3:00 p.m. No other school classes or additional students shall be permitted during those days and times.
3. **Site Plan.** The site plan submitted as part of the conditional use application shall be made part of the approval with any instructions or exceptions provided by the City Commission. Any changes to the plans after City Commission approval are subject to Sec. 14-203.10 of the Zoning Code.
4. **Restrictive covenant.** Within thirty (30) days of City Commission approval of the Application, the Applicant, property owner(s), its successors or assigns shall submit a restrictive covenant for City Attorney review and approval outlining all conditions of approval as approved by the City Commission. Failure to submit the draft restrictive covenant within the specified time frame shall render the approval void unless said time frame for submittal of the draft restrictive covenant is extended by the City Attorney after good cause as to why the time frame should be extended. It is recognized that the requirements contained in the restrictive covenant constitute regulatory conditions of approval and shall survive as regulatory conditions of approval even if the restrictive covenant is later found to be void or unenforceable.
5. **Drop Off and Pick Up Operation.** Spark Learning shall implement all drop off and pick up requirements for students specified in the Trip Generation Statement and Analysis prepared by Vala Group, Inc. dated September 7, 2023, including the following:
 - a. Drop off shall only be held Monday through Friday between 7:00 a.m. to 8:00 a.m. Pick up shall only be held Monday through Friday between 3:00 p.m. and 4:00 p.m.
 - b. Limit student drop off/pick up to on-site and Off-site B location, located at 127 Grand Avenue that is east of the property and accessed from Grand Avenue.
 - c. At the expense of the Applicant, a police officer shall be stationed on Grand Avenue to facilitate and enforce the drop off/pick up of students on all days and times students are scheduled to be dropped off/picked up for the first three months of every school year. After three (3) months following the start of every school year, the Applicant may petition the City to remove the requirement of a police officer traffic monitoring with the approval of the Public Works and Police departments. Upon Applicant's request, Public Works and Police may elect to reduce such three (3) month review period for subsequent school years, provided that Applicant provides sufficient evidence substantiating the effectiveness of its internal traffic monitoring procedures.
6. **Off-site Parking.** Off-site parking shall be operated as follows:
 - a. Off-site Parking A is west of the school and will only be used for faculty and employee parking. Student drop off/pick up shall not occur at Offsite Parking A.
 - b. Off-site Parking B is east of the school and will only be used for student drop off/pick up parking. Parents who use Off-site Parking B shall always walk their children between this area and the school.
 - c. Parking Agreements shall remain active between Spark Learning, Inc., DBA Spark Learning XIV and Baruch Properties, LLC (127 Grand Ave) and between Spark Learning, Inc., DBA Spark Learning XIV and Algimabe LLC (213 and 215 Grand Ave). The applicant shall submit the parking agreements annually prior to the renewal of the Certificate of Use. If the parking agreement cannot be renewed

- with either of the off-site parking locations, the Applicant shall submit a revised traffic and parking operations plan to be reviewed and approved by the directors of Public Works, Parking, and Planning & Zoning.
- d. If there are any gates at the parking lot drop off/pick up entry and exist points, the gates shall be opened a minimum of 30 minutes prior to the dismissal of school to avoid queuing on Grand Avenue.
 - e. Entry and exit driveways must comply with clear sight visibility requirements for both pedestrians and vehicular traffic.
7. **On-site Parking.** On-site parking shall only be used for drop off/pick up operations.
 8. **Public Realm Improvements.** All proposed landscaping and traffic flow modifications, including circular driveway on Jefferson, crosswalk on Grand Avenue, and installation of pavement marking and ground mounted traffic control devices to extend the existing school zone on Grand Avenue, shall require approval of Miami-Dade County and the City. The school speed zone times shall be coordinated with the existing G W Carver Elementary School speed zone times. Installation of all public realm improvements shall be completed prior to the issuance of the Certificate of Use.
 9. **Safety.** Consistent with the County's conditions of approval, students are not permitted to walk or ride bicycle to and from school without parent/guardian supervision. This shall be enforced by Spark Learning. Students will be accompanied by the parent, educator or aide if a student needs to leave the building.

6. ATTACHMENTS

- A. Applicant's submittal package.
- B. Notice mailed and legal advertisement published.
- C. PowerPoint Presentation.

Please visit the City's webpage at www.coralgables.com to view all application materials. The complete application also is on file and available for examination during business hours at the Planning and Zoning Division, 427 Biltmore Way, Suite 201, Coral Gables, Florida, 33134.

Respectfully submitted,



Jennifer Garcia, AICP, CNU-A
City Planner
City of Coral Gables, Florida

141 Grand Avenue – Conditional Use
City of Coral Gables
Planning and Zoning Board Meeting – October 11, 2023
Table of Contents

1. Legal Description
2. Application
3. Letter of Intent
4. Aerial
5. Photographs of Property
6. Survey
7. Architectural Drawings – Sheet 1
8. Architectural Drawings (Turning Radius) – Sheet 2
9. Owner’s Plans
10. Landscape Plans
11. Miami-Dade County Approval with Conditions
12. Trip Generation Report
13. Parking Agreement – 127 Grand Avenue
14. Parking Agreement – 215 Grand Avenue
15. Contact Information
16. Letter of Authorization
17. Lobbyist Registration
18. Warranty Deed
19. Certification Letter of Notice
20. Community Meeting Sign In Sheet
21. MDCPS Mailing Affidavit
22. Minutes from Community Meeting
23. Radius Map

141 Grand Avenue – Conditional Use
Legal Description

Lot 12, in Block 1-A, Combined and Supplemental Map of MAC FARLANE HOMESTE PLAT and ST. ALBAN'S PARK, according to the Plat thereof, recorded in Plat Book 5, at Page 81, of the Public Records of Dade County, Florida; less the following described property: That portion of Lot 12, in Block 1A, of Combined and Supplemental Map of MAC FARLANE HOMESTEAD PLAT and ST. ALBAN'S PARK, according to the Plat thereof, recorded in Plat Book 5, at Page 81, of the Public Records of Dade County, Florida, which lies Southerly of the following described line: Commence at the Southwest corner of said Lot 12, thence run North 5 degrees 09 minutes 54 seconds West along the West line of said Lot 12 for a distance of 23.79 feet to the Point of Beginning of the herein described line; thence run South 85 degrees 28 minutes 10 seconds East for a distance of 59.04 feet to the point of curvature of a circular curve to the left; thence run Southeasterly along the arc of said circular curve to the left having a radius of 1095.92 feet, through a central angle of 0 degrees 33 minutes 31 seconds for an arc distance of 10.68 feet to a point of intersection with the East line of said Lot 12 and to the END of the herein described line, said point of intersection being 12.62 feet North of the Southeast corner of said Lot 12 as measured along the East line of said Lot 12 and 13, in Block 1-A, of COMBINED AND SUPPLEMENTAL MAP OF MAC FARLANE HOMESTEAD PLAT AND ST. ALBAN'S PARK, according to the Plat thereof, recorded in Plat Book 5, Page 81, of the public records of Miami-Dade County, Florida.

Parcel Identification Number: 03-4120-006-0950



City of
Coral Gables,
Florida

Level

1

Review

General Procedures - Conditional

Address: 427 Biltmore Way, 2nd Floor, Coral Gables, Florida 33134

Email: planning@coralgables.com

Phone: 305.460.5211

Development Review General Procedures – Conditional Use

The Development Review Committee (DRC) is an administrative and technical committee which reviews policy and technical issues raised by a development project. The DRC is intended to streamline and coordinate the review of the development process by identifying, addressing, providing input, advice and comments regarding all applicable provisions and regulations. The review of the projects and comments on development proposals by the DRC shall not be construed to be an approval of any project presented to the Committee.

Application review request

The undersigned applicant(s)/agent(s)/property owner(s) request(s) Level One (1) Development Review Committee consideration and review for the following application(s) (please check all that apply):

- Abandonment and Vacations
- Comprehensive Plan Map Amendment - Small Scale
- Comprehensive Plan Map Amendment - Large Scale
- Conditional Use with Site Plan
- Conditional Use without Site Plan
- Coral Gables Mediterranean Architectural Design Special Locational Site Plan
- Development Agreement
- Development of Regional Impact
- Development of Regional Impact - Notice of Proposed Change
- Mixed Use Site Plan
- Planned Area Development Designation and Site Plan
- Planned Area Development Major Amendment
- Separation/Establishment of a Building Site
- Site Plan
- Subdivision Review for a Tentative Plat and Variance
- Transfer of Development Rights Receiving Site Plan
- University Campus District Modification to the Adopted Campus Master Plan
- Zoning Code Map Amendment
- Other: _____

Requests confirmed by Development Review Official (DRO) at pre-application meeting (signature): _____

Coral Gables Mediterranean Architecture Bonus

- Coral Gables Mediterranean Style Bonus - Table 1
- Coral Gables Mediterranean Style Bonus - Table 2
- Coral Gables Mediterranean Style Bonus - Table 3
- None



City of
Coral Gables,
Florida

Level

1

Review

General Procedures - Conditional

Address: 427 Biltmore Way, 2nd Floor, Coral Gables, Florida 33134

Email: planning@coralgables.com

Phone: 305.460.5211

Property information

Street address of the subject property: 141 Grand Ave., Coral Gables, FL 33133

Property/project name: 141 Grand LLC, a Florida limited liability company

Current land use classification(s): Commercial

Current zoning district(s): MX-1

Proposed land use classification(s) (if applicable): N/A

Proposed zoning district(s) (if applicable): N/A

Previous use(s)/current use(s) of the property/building(s): Office

Proposed use(s) of the property/building(s): Educational Facility

Size of property (square feet/acres) 5,224 sq. ft.

Total non-residential (i.e, commercial, office, etc.) floor area (total square feet/FAR): 2,312 sq. ft.

Total number of residential units per acre and total number of units N/A

Estimated cost of the existing/proposed building/project: \$20,000

Application(s) and date(s) of all previous City of Coral Gables submittals and type of actions related to existing/proposed building/project:

N/A

Project Legal Description: Lot(s): See attached Exhibit A

Block(s): _____

Section(s): _____

Listing of all folio numbers for subject property:

03-4120-006-0950



City of
Coral Gables,
Florida

Level

1

Review

General Procedures - Conditional

Address: 427 Biltmore Way, 2nd Floor, Coral Gables, Florida 33134

Email: planning@coralgables.com

Phone: 305.460.5211

General information

Applicant(s)/Agent(s) Name(s): Sparking Learning, Inc.

Telephone Contact No: 786-877-6552 Fax No. _____ Email joe@withprimer.com

Mailing Address: 548 Market St, PMB 60414 San Francisco, CA 94104
(City) (State) (ZIP Code)

Property Owner(s) Name(s): 141 Grand LLC, a Florida limited liability company

Telephone Contact No: 305-330-4808 Fax No. 305-330-4814 Email ikempler@kempstar.com

Mailing Address: 141 Grand Ave, Coral Gables, FL 33133
(City) (State) (ZIP Code)

Property Owner(s) Name(s): _____

Telephone Contact No: _____ Fax No. _____ Email _____

Mailing Address: _____
(City) (State) (ZIP Code)

Project Architect(s) Name(s): Masood Hajali, Ph.D., P.E.

Telephone Contact No: 305-898-9995 Fax No. _____ Email masood@calceng.com

Mailing Address: 2000 NW 89 Pl, Unit 102, Doral, FL 33172
(City) (State) (ZIP Code)

Provide the date(s) and type(s) of application(s) previously filed with the City of Coral Gables and type of reviews, approvals, actions related to this request:

N/A



City of
Coral Gables,
Florida

Level

1

Review

General Procedures - Conditional

Address: 427 Biltmore Way, 2nd Floor, Coral Gables, Florida 33134

Email: planning@coralgables.com

Phone: 305.460.5211

Application requirements and supporting information

Application submittal dates and meeting dates. Applications for the DRC shall be submitted in no later the first Friday of each month to tentatively be scheduled for the same monthly DRC meeting. DRC meetings are held the last Friday of each month, 9:30 a.m. First Floor Board Room, 427 Biltmore Way, Coral Gables, Florida 33134. Applicants and/or agents shall be required to attend the meeting to present the application request and respond to City Staff questions. All applications shall be complete at time of submittal.

Preapplication Conference Requirements. A Pre-application Conference is required with the Planning and Zoning Division in advance of application submittal to determine the information necessary to be filed with the application(s). The City reserves the right to request additional information as necessary.

Application submittal (order of documents). The order of the documents for the application submittal shall be as follows (required documents will be determined at pre-application meeting):

- Table of Contents with page numbers identifying all below documents.
- DRC Application.
- Statement of use and/or cover letter.
- Aerial.
- Photographs of property, adjoining properties and/or streetscape.
- Property ALTA survey and legal description.
- Architectural drawings (signed/sealed), including: Zoning chart / supporting information; site plan; floor plan(s); and all affected elevations. Maximum of 20 sheets shall be accepted.
- Landscape plan; vegetation assessment; and tree survey / relocation plan.
- Pedestrian amenities and streetscape plan.
- On-street parking analysis.
- Art in Public Places plan and/or statement.
- Lighting plan and signage plan.
- Underground utilities plan and/or statement.
- Ordinances, resolutions, covenants, development agreements, etc. previously granted for the property.
- Historical significance letter.
- City Concurrency Impact Statement (CIS).
- Traffic study.
- Name and contact information for property owner, applicant, architect, attorney, etc.
- City of Coral Gables Annual Registration Application and Issue Application Lobbyist forms.
- Warranty deed.
- Application fee equal to one tenth of one percent (.001) of the estimated total building construction cost as determined by the City (\$100.00 minimum fee and \$10,000.00 maximum fee). Payment shall be in check form, payable to the City of Coral Gables.
- Other: _____

 City of Coral Gables, Florida	Level 1	General Procedures - Conditional	
	Review	Address: 427 Biltmore Way, 2 nd Floor, Coral Gables, Florida 33134 Email: planning@coralgables.com	Phone: 305.460.5211

Posting of the property. The Applicant will post the subject property with a sign in accordance with the requirements of the Zoning Code indicating the DRC meeting date and location. The sign will be installed ten (10) days prior to the meeting and shall not be removed until after the meeting has been held, at which time it is the applicant’s responsibility to remove the sign.

Application submittal requirements

Electronic copy. A PDF of the entire application shall be submitted. The total file size shall not exceed 30 MB.

Applicant/agent/property owner/architect affirmation and consent

- (I) (We) affirm and certify to all of the following:
1. Submission of the following:
 - a. Warranty deed/tax record as proof of ownership for all properties considered as a part of the application request; or
 - b. Authorized as the applicant(s)/agent(s) identified herein to file this application and act on behalf of all current property owner(s) and modify any valid City of Coral Gables entitlements in effect during the entire review process.
 2. This request, application, application supporting materials and all future supporting materials complies with all provisions and regulations of the Zoning Code, Comprehensive Land Use Plan and Code of Ordinances of the City of Coral Gables unless identified and approved as a part of this application request or other previously approved applications. Applicant understands that any violation of these provisions renders the application invalid.
 3. That all the information contained in this application and all documentation submitted herewith is true to the best of (my) (our) knowledge and belief.
 4. Understand that the application, all attachments and fees become a part of the official records of the City of Coral Gables and are not returnable.
 5. Failure to provide the information necessary pursuant to the established time frames included but not limited to application submittal, submission of revised documents, etc. for review by City Staff and the designated reviewing entity may cause application to be deferred without further review until such time the requested information is submitted.
 6. All representatives of the application have registered with and completed lobbyist forms for the City of Coral Gables City Clerk’s office.
 7. Understand that under Florida Law, all the information submitted as part of the application are public records.
 8. The subject property will be posted by the Applicant in accordance with Zoning Code requirements. The sign shall be installed by the City ten (10) days prior to the meeting and shall not be removed until after the meeting, at which time it is the applicant’s responsibility to remove the sign.
 9. The application will not be heard unless the Applicant and/or agent is present at the DRC meeting.



City of
Coral Gables,
Florida

Level

1

Review

Development Review Committee Application

Address: 427 Biltmore Way, 2nd Floor, Coral Gables, Florida 33134

Email: planning@coralgables.com

Phone: 305.460.5211

Applicant(s)/Agent(s) Signature:

Joseph Whittaker Lindsay

Applicant(s)/Agent(s) Print Name:

Joseph Lindsay, Spark Learning, Inc.

Address: 382 NE 191 St #38216, Miami, FL 33179

Telephone: (415) 358-7164

Fax:

Email: joe@primer.com

NOTARIZATION

STATE OF FLORIDA/COUNTY OF Orange

The foregoing instrument was acknowledged before me this 7th day of April by
Joseph Whittaker Lindsay.

(Signature of Notary Public - State of Florida)

Karl Berry Joseph

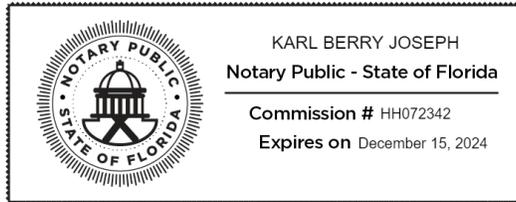

Notarized online using audio-video communication

Karl Berry Joseph

(Print, Type or Stamp Commissioned Name of Notary Public)

Personally Known OR Produced Identification; Type of Identification Produced
DRIVER LICENSE



City of
Coral Gables,
Florida

Level

1

Review

Development Review Committee Application

Address: 427 Biltmore Way, 2nd Floor, Coral Gables, Florida 33134

Email: planning@coralgables.com

Phone: 305.460.5211

Property Owner(s) Signature: <i>Ilan Kempler</i>	Property Owner(s) Print Name: Ilan Kempler 141 GRAND LLC
Property Owner(s) Signature:	Property Owner(s) Print Name:
Property Owner(s) Signature:	Property Owner(s) Print Name:

Address:

4000 Ponce De Leon Blvd Suite 830, Coral Gables, FL 33146

Telephone: 305-330-4808

Fax: 305.330.4814

Email: ikempler@kempstar.com

NOTARIZATION

TX Texas

STATE OF ~~FLORIDA~~ COUNTY OF Kerr

The foregoing instrument was acknowledged before me this 6th day of April 2023 by

Heather Cook _____

(Signature of Notary Public - State of ~~Florida~~ *TX*)

Heather Cook

Texas *TX*

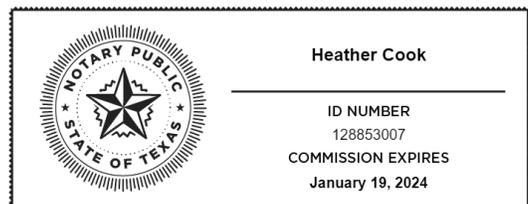

Notarized online using audio-video communication

(Print, Type or Stamp Commissioned Name of Notary Public)

Personally Known OR Produced Identification; Type of Identification Produced

DRIVER LICENSE



City of
Coral Gables,
Florida

Level

1

Review

Development Review Committee Application

Address: 427 Biltmore Way, 2nd Floor, Coral Gables, Florida 33134

Email: planning@coralgables.com

Phone: 305.460.5211

Architect(s) Signature:

Masood Hajali

Architect(s) Print Name:

Masood Hajali, Ph.D., PE.

Address: 2000 NW 89TH PL UNIT 102, Doral FL 33172

Telephone: +1 (305) 898-9995

Fax:

Email: masood@calceng.com

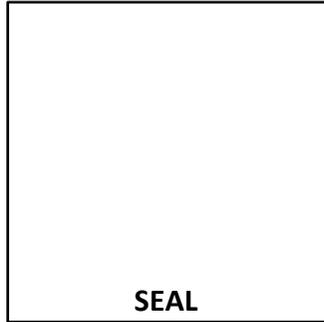

SEAL

NOTARIZATION

Texas

STATE OF ~~FLORIDA~~ / COUNTY OF Dallas

The foregoing instrument was acknowledged before me this 7th day of April 2023 by

Masood Hajali

Texas

(Signature of Notary Public - State of ~~Florida~~)

Melodie Ann Mitchell

Notarized online using audio-video communication

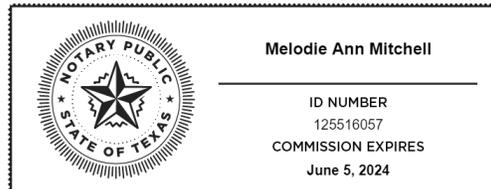

(Print, Type or Stamp Commissioned Name of Notary Public)

Personally Known OR Produced Identification; Type of Identification Produced

DRIVER LICENSE



City of
Coral Gables,
Florida

Level

1

Review

Development Review Committee Application

Address: 427 Biltmore Way, 2nd Floor, Coral Gables, Florida 33134

Email: planning@coralgables.com

Phone: 305.460.5211

June 2019

Exhibit A

Lot 12, in Block 1-A, Combined and Supplemental Map of MAC FARLANE HOMESTE PLAT and ST. ALBAN'S PARK, according to the Plat thereof, recorded in Plat Book 5, at Page 81, of the Public Records of Dade County, Florida; less the following described property: That portion of Lot 12, in Block 1A, of Combined and Supplemental Map of MAC FARLANE HOMESTEAD PLAT and ST. ALBAN'S PARK, according to the Plat thereof, recorded in Plat Book 5, at Page 81, of the Public Records of Dade County, Florida, which lies Southerly of the following described line: Commence at the Southwest corner of said Lot 12, thence run North 5 degrees 09 minutes 54 seconds West along the West line of said Lot 12 for a distance of 23.79 feet to the Point of Beginning of the herein described line; thence run South 85 degrees 28 minutes 10 seconds East for a distance of 59.04 feet to the point of curvature of a circular curve to the left; thence run Southeasterly along the arc of said circular curve to the left having a radius of 1095.92 feet, through a central angle of 0 degrees 33 minutes 31 seconds for an arc distance of 10.68 feet to a point of intersection with the East line of said Lot 12 and to the END of the herein described line, said point of intersection being 12.62 feet North of the Southeast corner of said Lot 12 as measured along the East line of said Lot 12 and 13, in Block 1-A, of COMBINED AND SUPPLEMENTAL MAP OF MAC FARLANE HOMESTEAD PLAT AND ST. ALBAN'S PARK, according to the Plat thereof, recorded in Plat Book 5, Page 81, of the public records of Miami-Dade County, Florida.

Parcel Identification Number: 03-4120-006-0950

SPARK LEARNING, INC.

04/07/2026

City of Coral Gables
Development Services
427 Biltmore Way
Coral Gables, Florida 33134

RE: Authorization of Principal

To whom it may concern:

Please let it be known that this is our written authorization from Spark Learning Inc., lobbyist Edward G. Baker is authorized to represent Spark Learning Inc. and obtain permits and plans for the property address located at 141 Grand Ave, Coral Gables, Florida, 33133.

DocuSigned by:
Joe Lindsay
C9DBD82476FD49E...

Joe Lindsay

September 26, 2023

Ms. Jennifer Garcia
City Planner
Development Services
City of Coral Gables
427 Biltmore Way
Coral Gables, Florida 33134

Re: Letter of Intent for Conditional Use Application for a private School located at 141 Grand Avenue, Coral Gables, Florida 33133, Folio No.: 03-4120-006-0950

Dear Ms. Garcia:

The undersigned is legal counsel to Spark Learning, Inc., a Delaware corporation, DBA Spark Learning XIV (“**Applicant**”), the lessee of that certain real property located at 141 Grand Avenue, Coral Gables, Florida 33133, Folio No.: 03-4120-006-0950 (the “**Property**”). The Applicant intends to establish a private School at the Property (this “**Project**”). This letter shall constitute our letter of intent in support of the application for a Conditional Use approval for a proposed private School, pursuant to Section 14-203 of the Coral Gables Zoning Code (the “**Code**”). The Applicant intends to make minimal exterior and interior modifications, including increasing the rear wall to 6’, adding landscaping and reconfiguring the rear parking lot to accommodate a drop off and pickup area.

The Property is zoned Mixed Use-1, which permits a School by Conditional Use, pursuant to Section 3-101 of the Code. In accordance with the requirements of the Code pertaining to a Conditional Use, this Project will comply as follows:

1. The proposed conditional use is consistent with and furthers the goals, policies and objectives of the Comprehensive Plan and furthers the purposes of these regulations and other City ordinances and actions designed to implement the Plan.

Response: This Project will satisfy Goal FLU-1 of the Comprehensive Plan to protect, strengthen, and enhance the City of Coral Gables as a vibrant community ensuring that it is a very desirable place to work, live and play. The establishment of this Project will ensure that residents have easy access to quality education for their children.

2. The available use to which the property may be put is appropriate to the property that is subject to the proposed conditional use and compatible with existing and planned uses in the area.

Response: This Project is adjacent to an existing School (George Washington Carver Elementary and Middle School), so this Project is appropriate with the existing and planned uses in the area.

3. The proposed conditional use does not conflict with the needs and character of the neighborhood and the City.

Response: This Project will add needed educational options to the City, which is burgeoning with new residents.

4. The proposed conditional use will not adversely or unreasonably affect the use of other property in the area.

Response: This Project will have a minimal impact on neighboring properties given the limited hours and days of the week that this Project will be in operation (e.g., Monday to Friday from 7:00 am to 4:00 pm). Given the number of students proposed at this Project (e.g., 35 students), the impact on traffic and noise will also be minimal.

5. The proposed use is compatible with the nature, condition and development of adjacent uses, buildings and structures and will not adversely affect the adjacent uses, buildings or structures.

Response: This Project is utilizing an existing building and will not adversely affect the adjacent uses, buildings or structures anymore than they are currently being impacted.

6. The parcel proposed for development is adequate in size and shape to accommodate all development features.

Response: This Project is utilizing an existing building.

7. The nature of the proposed development is not detrimental to the health, safety and general welfare of the community.

Response: This Project is utilizing an existing building. This Project will not have a negative impact on the health, safety and general welfare of the community. This Project will add to the safety of the area with more pedestrian traffic on the north side of Grand Avenue.

8. The design of the proposed driveways, circulation patterns and parking is well defined to promote vehicular and pedestrian circulation.

Response: This Project has been designed to promote vehicular and pedestrian circulation during pick up and drop off times. The Applicant has entered into agreements with two off-site properties for parking located at 213/215 Grand Avenue (“**Offsite Area A**”) and 127 Grand Avenue (“**Offsite Area B**”). As requested by Miami-Dade County, Offsite Area A will be solely used for staff and teachers. The Property and Offsite Area B will be used by parents for student drop off and pick up. Drop off and pick up will occur on a staggered schedule with parents assigned a 10-minute window in the morning and afternoon. School staff will perform traffic control to minimize queuing and promote vehicular and pedestrian circulation.

9. The proposed conditional use satisfies the concurrency standards of Section 14-218. and will not adversely burden public facilities, including the traffic-carrying capacities of streets, in an unreasonable or disproportionate manner.

Response: As described in the traffic study performed by Vala Group, Inc., which accompanies this application, the impact on traffic will be minimal. It is also worth noting that Miami-Dade County’s Department of Transportation and Public Works approved this Project.

The Applicant will operate a private School under the business name of Primer Microschools. As noted above, this Project is projected to serve approximately thirty-five (35) students from grades 3 through 8 with hour of operations of 7:00 am to 4:00 pm. The school day will be from 8:00 am to 3:00 pm.

Primer Microschools are schools of 15-50 students led in person by an exceptional educator—either a former teacher or homeschooler—who acts as the Leader of the Microschool. Students work on projects with other kids, read, draw, think, and spend their time in pursuit of their own self-driven goals. At specific points each day, students log on and attend virtual classes with Primer Microschool teachers for various core subjects. Primer Microschool teachers are chosen to lead their specific subject of expertise from among the best teachers in the US, allowing for unparalleled quality of instruction. The combination of in person and online infrastructure unlocks amazing experiences for kids.

For all of the aforementioned reasons, we respectfully request your favorable review and support of this application. Thank you in advance for your consideration regarding this application. If you have any questions, please feel free to contact me at 305-714-4379 or ebaker@bergersingerman.com.

Respectfully submitted,



Edward Baker, Esq.

141 Grand Avenue – Conditional Use
Aerial

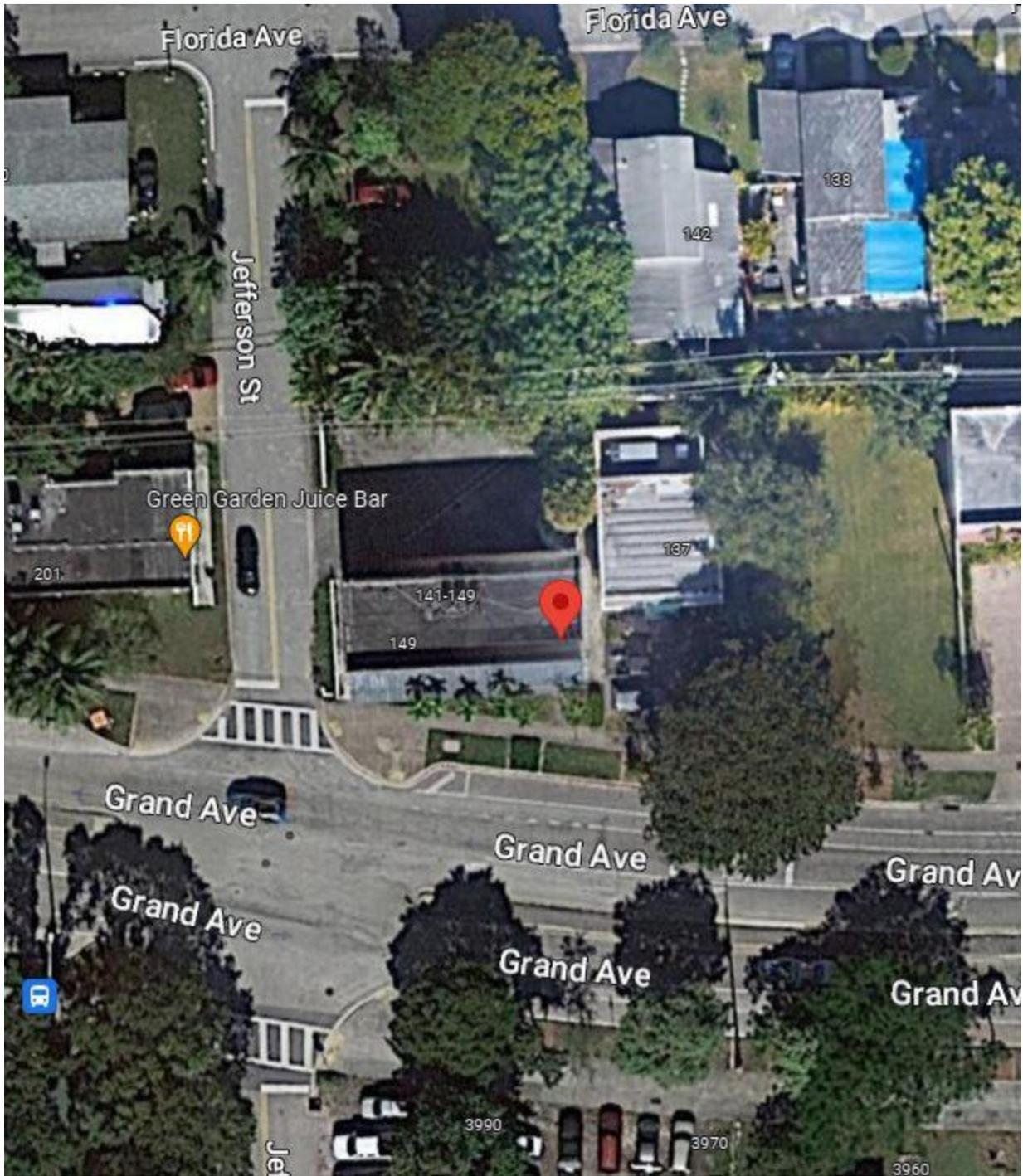

141 Grand Avenue – Conditional Use
Photographs of Property



141 Grand Avenue – Conditional Use
Photographs of Property



LEGEND

- — — — — CENTER LINE
- — — — — RIGHT-OF-WAY
- — — — — PROPERTY LINE



Calc Engineering

CALC ENGINEERING
 www.calceng.com
 2000 NW 84th PL. Unit 102
 DORAL, FL 33172
 Phone: (305) 898-9995
 ENGINEERING BUSINESS
 CA CERTIFICATION:
 32566
 MASOOD HAJALI P.E.
 LIC #62038

Sparks Learning Center
 141 Grand Avenue,
 Coral Gables, Florida, 33133



EXISTING METAL FENCE TO REMAIN

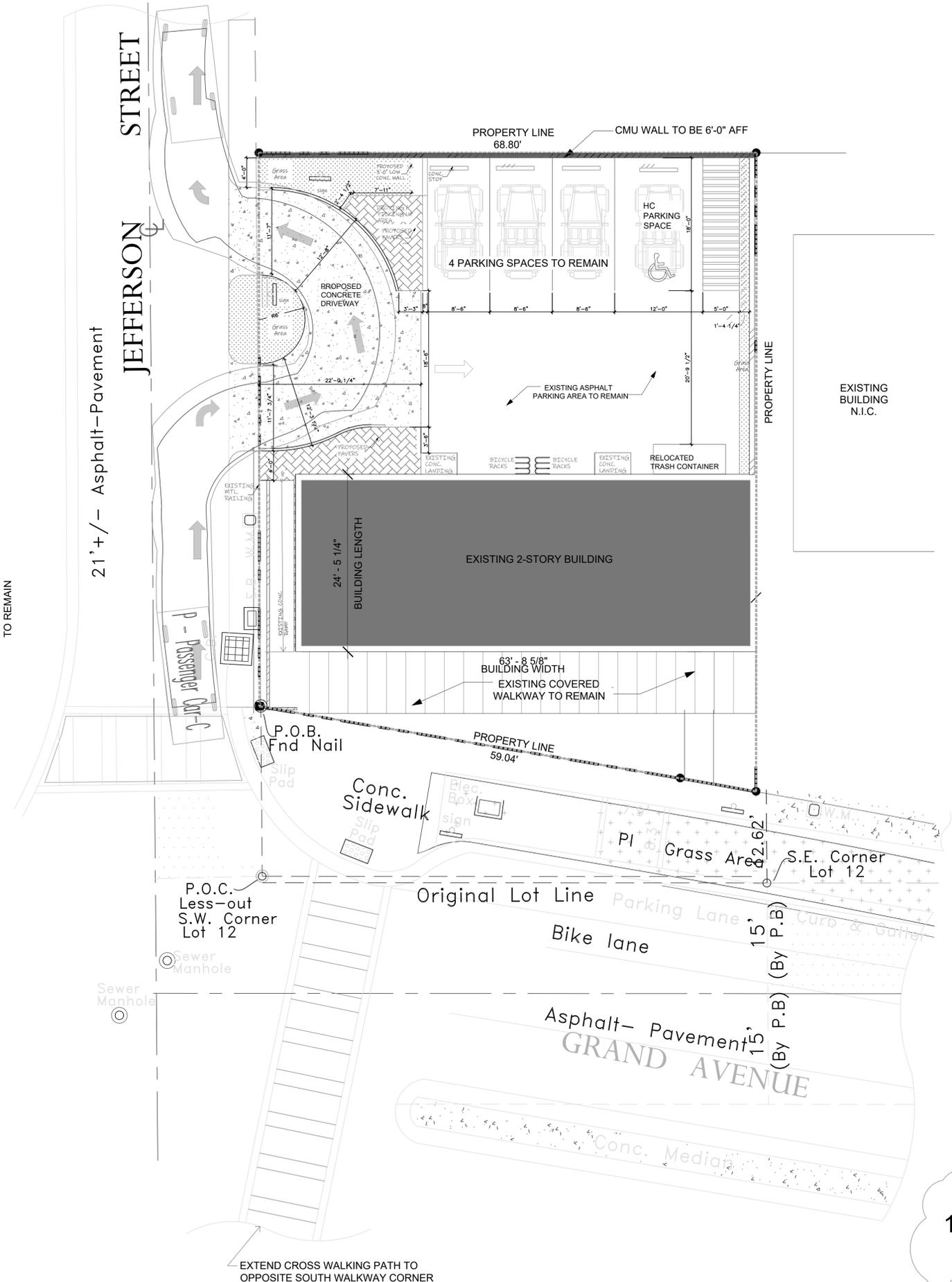

SITE PLAN
 1
 1/8" = 1'-0"

Sunshine811
 Call 811 or visit sunshine811.com two full business days before digging to have buried facilities located and marked.
 Check positive response codes before you dig!

BD COMMENTS	X
COMMENTS	
BD COMMENTS	8.2.2023
BD COMMENTS	9.11.2023

PROPOSED FLOOR PLANS
06 / 04 / 2023
Project Number
23266
A1A
Drawn By

GENERAL NOTES

1.2. THE CONTRACTOR AGREES THAT HE, HIS MANAGEMENT TEAM (ESTIMATOR, PROJECT MANAGER, PROJECT ENGINEERS, SUPERINTENDENTS, AND SUBCONTRACTORS AND PRINCIPAL SUPERVISORY PERSONNEL, ETC.) HAS VISITED THE SITE, EXAMINED THE SITE AND THE LOCATION OF THE PROPOSED WORK, AND EXISTING IMPROVEMENTS, AND CONDITIONS AND PHYSICAL CHARACTERISTICS OF THE JOB SPACE. THE CONTRACTOR(S) SHALL INCLUDE IN HIS BUDGET ALL COSTS ASSOCIATED WITH, AND PERTAINING TO, THE SATISFACTORY COMPLETION OF THE PROJECT AND THE COMPLETE INSTALLATION OF ALL ASSOCIATED SYSTEMS, INCLUDING THE REMOVAL AND RELOCATION OF ANY AND ALL OBJECTS OR OBSTRUCTIONS THAT MAY BE ENCOUNTERED IN THE COMPLETION OF THE WORK THAT MAY NOT HAVE BEEN PREVIOUSLY DOCUMENTED IN THE CONSTRUCTION DOCUMENTS.

1.3. PLANS AND DETAILS ARE COMPLEMENTARY AND MUTUALLY EXPLANATORY AND WHAT IS REQUIRED BY ONE, SHALL BE AS BINDING AS IF REQUIRED BY ALL, AND ARE NOT INTENDED TO BE USED AS SHOP DRAWINGS. WHERE VARIANCES, DISCREPANCIES, ETC. OCCUR BETWEEN DRAWINGS AND SPECIFICATIONS, OR WITHIN EITHER DOCUMENTS ITSELF, THE ITEM OR ARRANGEMENT OF BETTER QUALITY AND OR HIGHER COST SHALL BE INCLUDED IN THE CONTRACT.

1.4. CONTRACTOR SHALL PREPARE A CONSTRUCTION SCHEDULE SUBJECT TO REVIEW AND APPROVAL BY OWNER

1.5. THE CONTRACTOR SHALL MAINTAIN A COPY OF ALL APPLICABLE CODES AND STANDARDS RELEVANT TO THIS PROJECT ON SITE AT ALL TIMES, AND SHALL COMPLY WITH ALL REQUIREMENTS OF THE CURRENT FLORIDA BUILDING CODE, AND ALL APPLICABLE FEDERAL, STATE AND LOCAL CODES, STANDARDS, REGULATIONS, AND LAWS.

1.6. THE CONTRACTOR SHALL MAINTAIN A COMPLETE AND CURRENT SET OF PERMIT DRAWINGS ON-SITE AT ALL TIMES ALONG WITH ALL REVISIONS TO THE PERMIT, INCLUDING PERMITTED SHOP DRAWINGS AND CALCULATIONS. SAID DRAWINGS ALONG WITH ALL INSPECTION LOGS, AND PERMITS MUST BE MAINTAINED IN AN EASILY ACCESSIBLE SPACE FOR THE OWNER, ARCHITECT, ENGINEERS, AND BUILDING OFFICIALS TO REVIEW.

1.7. THE CONTRACTOR SHALL REVIEW ALL CONTRACT DOCUMENTS, PERMIT DOCUMENTS, DIMENSIONS, JOB-SITE CONDITIONS, AND COORDINATE WITH FIELD DIMENSIONS, AND PROJECT SHOP DRAWINGS PRIOR TO CONSTRUCTION SPACE. THE CONTRACTOR SHALL MAKE NOTE OF ANY AND ALL DISCREPANCIES THAT PREVENT THE INSTALLATION OF ANY ASPECT OF THE CONSTRUCTION TO ACHIEVE THE CHARACTER AND APPEARANCE DEFINED IN THE CONTRACT DOCUMENTS, THE CONTRACTOR SHALL REPORT ANY AND ALL DISCREPANCIES REGARDLESS OF THEIR NATURE TO THE ARCHITECT IN WRITING PRIOR TO PROCEEDING WITH THE WORK, REASONABLY ASSESS THE CONDITION AND DETERMINE AN APPROPRIATE SOLUTION.

1.8. ITEMS AFFECTING ALL TRADES ARE PLACED THROUGHOUT THE DRAWINGS. NO "CHANGE ORDERS" FOR MISSED ITEMS IN OTHER SECTIONS OF THE WORK WILL BE PERMITTED. THE CONTRACTOR SHALL PROMPTLY NOTIFY THE ARCHITECT IN WRITING OF AMBIGUITY, INCONSISTENCY OR ERROR WHICH THEY DISCOVER UPON EXAMINATION OF THE CONTRACT DOCUMENTS, THE SITE, OR LOCAL CONDITIONS.

1.9. THE CONTRACTOR SHALL PERFORM ALL WORK IN A FIRST CLASS WORKMANSHIP LIKE MANNER.

1.10. THE ARCHITECT, OWNER AND OR ENGINEER(S) SHALL NOT BE RESPONSIBLE FOR, NOR HAVE CONTROL OR CHARGE OVER THE CONSTRUCTION MEANS, METHODS, SEQUENCES, OR PROCEDURES OR FOR THE SAFETY PRECAUTION PROGRAMS. THE CONTRACTOR IS SOLELY RESPONSIBLE FOR DAMAGES OR INJURIES DUE TO HIS ACT OR NEGLIGENCE.

1.11. NO UTILITIES, DATA OR COMMUNICATION CABLES, POWER OR BUILDING OPERATIONS SHALL BE INTERRUPTED WITHOUT PRIOR APPROVAL OF OWNER'S REPRESENTATIVE. THE CONTRACTOR SHALL BE RESPONSIBLE FOR DAMAGES CAUSED BY UNAUTHORIZED INTERRUPTION OF EXISTING UTILITIES, CONTROLS, COMMUNICATION AND DATA LINES, ETC. CAUSED BY THE CONTRACTOR OR SUBCONTRACTOR AND SHALL MAKE IMMEDIATE REPAIR AND THEN NOTIFY THE OWNER'S REPRESENTATIVE.

1.12. PROTECT ADJACENT AREAS FROM DAMAGE AND BE RESPONSIBLE FOR DAMAGES THEY CAUSE. PROVIDE BARRICADES AND BARRIERS AS REQ'D TO PROTECT ADJACENT AREAS AND PERSONNEL AND PREVENT MIGRATION OF DUST AND EXCESS DEBRIS. PROVIDE FENCE & PROTECTION TO PROTECT ADJACENT BUILDINGS. PROVIDE BARRICADES AND/OR SHELTER FOR PEDESTRIANS ADJACENT TO PROJECT.

1.13 AS-BUILT CONDITIONS MAY NOT COINCIDE WITH THOSE INDICATED ON THE CONSTRUCTION DOCUMENTS. THE CONTRACTOR SHALL BE RESPONSIBLE FOR DEMOLITION, BUT NOT LIMITED TO, ALL THE ITEMS LISTED FOR DEMOLITION IN THE CONSTRUCTION DOCUMENTS. THE CONTRACTOR SHALL INSPECT THE EXISTING CONDITIONS AND SHALL BE RESPONSIBLE FOR DEMOLITION OF EXISTING WORK AS REQUIRED TO COMPLETE THE NEW WORK.

2. LICENSING :

2.1. THE CONTRACTOR AND ALL SUBCONTRACTORS SHALL BE LICENSED BY THE STATE OF FLORIDA, AND DADE COUNTY, LICENSES AND CLEARANCES SHALL CONFORM TO ALL BUILDING SECURITY POLICIES AND REGULATIONS.

3. ORDINANCES :

3.1. THE CONTRACTOR SHALL BE RESPONSIBLE FOR ASCERTAINING THE REQUIREMENTS OF AND ADHERING TO ALL NOISE ORDINANCES OR OTHER ORDINANCES THAT MAY RESTRICT THE ACTIVITIES OF THE WORK ON THIS JOB. CONTRACTOR SHALL FOLLOW THE REQUIREMENTS OF THE APPROVED M.O.T.

4. PERMITS :

4.1. THE CONTRACTOR SHALL BE RESPONSIBLE FOR OBTAINING ALL REQUIRED PERMITS PRIOR TO THE COMMENCEMENT OF WORK, THE REQUESTING AND COORDINATION OF ALL INSPECTIONS AND APPROVAL OF ALL ASPECTS OF HIS WORK, AND OBTAINING ALL TEMPORARY AND FINAL CERTIFICATES OF OCCUPANCY.

5. DEBRIS AND DISPOSAL :

5.1. THE CONTRACTOR SHALL REMOVE FROM THE SITE AND LEGALLY DISCARD IN A TIMELY MANNER ALL CONSTRUCTION DEBRIS THAT WILL NOT BE REUSED OR RELOCATED ELSEWHERE IN THE PROJECT.

6. HAZARDOUS MATERIALS :

6.1. IF ANY HAZARDOUS MATERIALS, INCLUDING ASBESTOS, ARE ENCOUNTERED DURING DEMOLITION WORK, THEY SHALL BE REMOVED IN ACCORDANCE WITH CODES, LAWS AND ORDINANCES

7. MATERIALS AND EQUIPMENT :

7.1. THE CONTRACTOR IS RESPONSIBLE FOR ALL MATERIALS, EQUIPMENT, AND APPLIANCES THAT ARE TO BE USED. THE CONTRACTOR SHALL PROVIDE PROTECTION FROM VANDALISM, THEFT, WEATHER, DUST, NOISE, AND ANY OTHER SOURCE OF DAMAGE OR LOSS.

8. HURRICANE / WINDSTORM PLAN :

8.1. THE CONTRACTOR SHALL PREPARE AND MAINTAIN A HURRICANE PREPAREDNESS PLAN. THE CONTRACTOR SHALL MAINTAIN SAID PLAN IN A LOCATION THAT IS READILY ACCESSIBLE FOR REVIEW BY THE OWNER AND OR ARCHITECT.

8.1.1. THE HURRICANE PLAN SHALL INCLUDE A LIST OF CONTACTS IN THE EVENT THAT A HURRICANE WATCH IS POSTED AND WILL ALSO ADDRESS WHAT MEASURES ARE TO BE TAKEN TO SECURE THE CONSTRUCTION SITE IN THE EVENT OF NOTIFICATION BY THE NATIONAL WEATHER SERVICE OF AN IMPENDING HURRICANE OR WINDSTORM THAT MAY THREATEN THE JOB.

8.1.2. THE HURRICANE PLAN SHALL ADDRESS HOW THE CONTRACTOR WILL MOBILIZE THE PROJECT FOLLOWING A WIND OR HURRICANE EVENT AND DOCUMENTATION OF DAMAGES AND HOW REPAIRS WILL BE HANDLED IN THE EVENT OF A LOSS.

9. DAMAGES :

9.1. IN THE EVENT OF DAMAGES TO THE BUILDING WHICH REQUIRE ASSESSMENT FOR AN INSURANCE CLAIM, THE CONTRACTOR MUST IMMEDIATELY NOTIFY THE OWNER OF THE CIRCUMSTANCES SURROUNDING THE LOSS, DOCUMENT DAMAGES, DETERMINE AND PRICE REPAIRS, DETERMINE IMPACT TO THE PROJECT SCHEDULE, SUBMIT ALL INFORMATION TO THE OWNER WITHIN 72 HOURS OF A LOSS.

10. COORDINATION :

10.1. CONTRACTOR SHALL COORDINATE THE WORK OF ALL TRADES AT THE TIME THE WORK IS PERFORMED. CONTRACTOR SHALL ALSO COORDINATE ITS WORK WITH THE OTHER CONTRACTORS WORKING ON THE BUILDINGS AND SITEWORK. NO ADDITIONAL PAYMENTS SHALL BE MADE FOR THE CONTRACTOR'S FAILURE TO CORRECT CONFLICTING FIELD CONDITIONS AFTER THE WORK HAS BEEN COMPLETED.

11. SCHEDULING OF WORK :

11.1. THE CONTRACTOR SHALL WORK AND RETAIN COOPERATION WITH THE OWNER AND TENANT(S) (IF ANY) IN SCHEDULING THEIR WORK IN ORDER TO CAUSE THE LEAST INCONVENIENCE TO PERSONNEL AND PROPERTY.

12. TESTS :

12.1. THE CONTRACTOR SHALL COORDINATE ALL REQUIRED TESTS. PAYMENT OF ALL TEST SHALL BE AS INDICATED IN THE AGREEMENT BETWEEN THE OWNER/CONTRACTOR OR GENERAL CONDITIONS. IF NOT SPECIFICALLY DEFINED, THESE COSTS SHALL BE BORNE BY THE CONTRACTOR.

13. TYPICAL DETAILS :

13.1. CONTRACTOR SHALL RESOLVE QUESTIONS REGARDING APPLICABILITY OF TYPICAL DETAILS WITH THE ARCHITECT/ENGINEER. DETAILS LABELED AS "TYPICAL DETAILS, OR (TYP.) ON THE DRAWINGS APPLY TO ALL SITUATIONS THAT ARE THE SAME OR SIMILAR TO THOSE SPECIFICALLY DETAILED OR EXISTING AT THE SITE. SUCH DETAILS APPLY WHETHER OR NOT THEY ARE KEVED IN AT EACH LOCATION.

14. CLEANING :

14.1. PROVIDE CLEANING AS INDICATED IN THE CONTRACT FOR CONSTRUCTION BETWEEN THE OWNER/CONTRACTOR. THOROUGHLY CLEAN THE PREMISES TO MAKE READY FOR OPENING. CLEAN ALL SURFACES INTERIOR AND EXTERIOR, FREE OF ALL DIRT AND REFUSE CAUSED BY DEBRIS FROM ALL INSTALLATION TECHNIQUES OF THE TRADES INCLUDING:

- A. POLISHING ALL HARDWARE.
- B. THOROUGHLY CLEANING ALL FINISHES AREAS INSIDE AND OUT.
- C. CLEANING SHELVES INSIDE AND OUT.
- D. ALL MIRRORS, GLASS STOREFRONTS, TERRACES, WINDOWS AND METAL FRAMING TO BE CLEANED INSIDE AND OUT, WHERE POSSIBLE.
- E. BROOM CLEAN ALL FLOOR SLABS.
- F. CLEAN OR TOUCH UP ALL PAINTED SURFACES WHICH ARE SOILED. THE GENERAL CONTRACTOR IS TO DELIVER TO THE OWNER A CLEAN BUILDING PRIOR TO OPENING FINAL INSPECTION.

15. USE OF DRAWINGS :

15.1. THESE DRAWINGS ARE BEING PREPARED FOR THE PURPOSE OF PERMITTING. THESE DRAWINGS ARE NOT TO BE USED FOR MAINTENANCE PURPOSES AS ACTUAL CONDITIONS MAY VARY FROM THOSE SHOWN ON THESE DRAWINGS DUE TO CHANGE ORDERS, ALTERATIONS BY OTHERS, FIELD CONDITIONS, ETC.

15.2. THESE DRAWINGS AND RELATED DOCUMENTS DETAIL WORK FOR THIS SPECIFIC PROJECT INDICATED BY THE PROJECT NUMBER AND LISTED LOCATION. THESE DOCUMENTS SHALL REMAIN THE PROPERTY OF ARCHITECT COMPANY, AND MAY NOT BE USED FOR ANY OTHER PROJECT OR PURPOSE WITHOUT WRITTEN PERMISSION OF THE ARCHITECT, ARCHITECT COMPANY.

15.3. DO NOT REPRODUCE THE DRAWINGS FOR USE AS SHOP DRAWINGS.

15.4. DO NOT SCALE DRAWINGS, WRITTEN DIMENSIONS TAKE PRECEDENCE.

16. WALL DIMENSIONS :

16.1. AT INTERIOR WALL DIMENSIONS ARE CENTER OF WALL TO CENTER OF WALL. ALL EXTERIOR WALL DIMENSIONS ARE TO FACES OF BLOCK WALLS OR CONCRETE (WHERE APPLICABLE).

17. TENANT FURNISHED MATERIALS

17.1. ALL OWNER-FURNISHED MATERIAL, IF ANY, ARE TO BE FURNISHED VIA TAILGATE DELIVERY ONLY. THE CONTRACTOR IS RESPONSIBLE FOR THE UNLOADING, EXAMINATION, AND TRANSPORTATION OF OWNER FURNISHED MATERIALS FROM THE POINT OF OFF-LOADING TO THE JOB-SITE OR STORAGE AREA AS APPLICABLE. MATERIALS WILL BE DELIVERED TO THE CLOSEST AVAILABLE TRUCK DOCK OR ALTERNATE LOCATION AS DIRECTED BY THE OWNER.

18.1. SUBSTITUTION OF MATERIALS OR EQUIPMENT OTHER THAN SPECIFIED SHALL BE PERMITTED UPON WRITTEN AUTHORIZATION FROM THE ARCHITECT AND OWNER.

18.2. THE CONTRACTOR SHALL BEAR THE BURDEN OF PROOF THAT SUCH SUBSTITUTION IS EQUAL TO SPECIFIED ITEM AND CAN BE OBTAINED IN A TIMELY MANNER.

18.3. THE CONTRACTOR SHALL BE RESPONSIBLE FOR THE COORDINATION OF ALL SUBSTITUTE ITEMS WITH ALL ASSOCIATED/IMPACTED TRADES.

18.4. THE CONTRACTOR SHALL BE RESPONSIBLE FOR ALL DESIGN COSTS ASSOCIATED WITH A SUBSTITUTION.

19. PERMANENT FIRE EXTINGUISHERS :

19.1. FIRE EXTINGUISHERS OF THE TYPE AND QUANTITY APPROVED BY THE LOCAL FIRE OFFICIAL AND THE OWNERS CASUALTY INSURER ARE TO BE PROVIDED IN SURFACE MOUNTED CABINETS.

19.2. ALL FIRE EXTINGUISHER CABINETS LOCATED IN A FIRE RATED WALL ASSEMBLY SHALL BE PROVIDED AS A FIRE RATED CABINET.

19.3. THE CONTRACTOR SHALL PROVIDE SUFFICIENT ALLOWANCE TO INSTALL ALL REQUIRED FIRE EXTINGUISHERS & CABINETS.

19.4. THE CONTRACTOR MAY NOT ALLOCATE ANY TEMPORARY CONSTRUCTION USE FIRE EXTINGUISHERS AS PERMANENT FIRE EXTINGUISHERS.

19.5. ALL FIRE EXTINGUISHERS AND CABINETS SHALL BE INSTALLED IN ACCORDANCE WITH ALL APPLICABLE BUILDING CODES AND HANDICAP ACCESSIBILITY REQUIREMENTS.

20. FLAME SPREAD RATING :

20.1. ALL MATERIAL USED IN THE INTERIOR OF THE PROJECT MUST MEET THE FLAME SPREAD RATINGS PER THE GOVERNMENT CODE. PROOF OF THESE FLAME SPREAD RATINGS MUST BE INCLUDED AS A PART OF A FINAL INSPECTION PRIOR TO ISSUANCE OF A CERTIFICATE OF OCCUPANCY.

21. FRAMING :

21.1. ALL WOOD BLOCKING SHALL BE FIRE RETARDANT TREATED (F.R.T.) LUMBER. NO F.R.T. MATERIAL MAY BE USED IN THE CEILINGS PLENUM OR ABOVE SPRINKLER COVERAGE, OR AS REQUIRED / RESTRICTED BY LOCAL GOVERNING CODES. INSTALL ALL WORK PLUMB, LEVEL, TRUE AND STRAIGHT WITH NO DISTORTIONS. SHIM AS REQUIRED USING CONCEALED SHIMS.

22. COMPLETENESS OF WORK :

22.1. ANY MATERIAL OR LABOR, NEITHER SHOWN ON THE DRAWINGS, NOR SPECIFIED, BUT WHICH IS OBVIOUSLY NECESSARY TO COMPLETE THE WORK OF A SIMILAR NATURE OR TO COMPLY WITH ALL CODES SHALL BE FURNISHED WITHOUT ADDITIONAL COST.

22.2. ALL WORK STARTED BY THE CONTRACTOR SHALL BE COMPLETED IN ITS ENTIRETY TO ITS FINAL COMPLETED STATE WHETHER COMPLETELY DEFINED IN THE DRAWINGS OR NOT.

22.3. THE WORK SHALL INCLUDE THE PROVISIONS OF ALL MATERIALS, CUTTING, EXTENSIONS, CONNECTIONS, PATCHING, PAINTING, REPAIRING, ADAPTING AND OTHER WORK INCIDENTAL THERE TO, TOGETHER WITH SUCH TEMPORARY CONNECTIONS AS MAY BE REQUIRED. PROVIDE ALL NECESSARY SEALING OF PENETRATIONS LEFT FROM REMOVED EQUIPMENT OR PRODUCED BY THIS WORK. UNLESS OTHERWISE NOTED ALL WORK AND MATERIALS SHALL BE NEW AND PROVIDED BY THIS CONTRACTOR. THE WORK SHALL ALSO INCLUDE THE REMOVAL AND DISPOSAL OF MATERIALS FROM THE SITE.

22.4. WHERE PRESENT WORK IS DAMAGED IN THE EXECUTION OF THIS CONTRACT OR WHERE OPENINGS ARE LEFT DUE TO THE REMOVAL OF PIPES, EQUIPMENT OR APPARATUS, THE SAME SHALL BE REPAIRED OR CLOSED UP TO CORRESPOND IN MATERIAL, QUALITY, SHAPE AND FINISH WITH THAT OF SIMILAR AND ADJOINING WORK AND FIRE RATING, UNLESS OTHERWISE CALLED FOR. WHERE DAMAGE IS NOT REPAIRABLE, NEW ITEMS OR EQUIPMENT SHALL BE PROVIDED AT CONTRACTOR'S EXPENSE.

23. FINISHED FLOORING :

23.1. GENERAL CONTRACTOR WILL BE RESPONSIBLE FOR PROTECTING FINISHED FLOORING SURFACES FROM DAMAGE BY SUB-CONTRACTORS.

23.2. THE CONTRACTOR SHALL EXAMINE THE FLOOR SLAB CONDITION TO DETERMINE TO WHAT EXTENT FLOOR PREPARATION, LEVELING, CHIP HAMMERING, ETC. WILL BE NECESSARY TO FURNISH A SMOOTH, LEVEL SUBSTRATE FOR THE PROPER INSTALLATION OF ALL FLOORING MATERIALS. THE COST OF SUCH WORK SHALL BE THE RESPONSIBILITY OF THE CONTRACTOR. UNEVEN SUBSTRATE WILL NOT BE ACCEPTED AS AN EXCUSE FOR POORLY INSTALLED FLOORING MATERIALS.

24. DELEGATE ENGINEERS :

24.1. AS A MINIMUM, THE FOLLOWING SYSTEMS AND COMPONENTS REQUIRE FABRICATION AND ERECTION DRAWINGS DESIGN, DETAILED AND SEALED BY A DELEGATED ENGINEER REGISTERED IN FLORIDA.

- A. GLAZED EXTERIOR WALL SYSTEMS
- B. ROOFTOP EQUIPMENT SCREENS.

25. STRUCTURAL ALUMINUM :

25.1. THE DESIGN, FABRICATION, AND ASSEMBLY OF STRUCTURAL ALUMINUM FOR BUILDINGS OR STRUCTURES SHALL CONFORM TO SPECIFICATIONS FOR ALUMINUM STRUCTURES, ALUMINUM CONSTRUCTION MANUAL, SECTION 1, OF ALUMINUM ASSOCIATION.

26. SHOP DRAWINGS :

26.1. REFER TO SPECIFICATIONS FOR SHOP DRAWINGS PROCEDURE.

27. PENETRATIONS AND CUTTING :

27.1. CUTTING OR DRILLING OF ANY STRUCTURAL MEMBER IS NOT PERMITTED WITHOUT THE PRIOR WRITTEN APPROVAL OF THE ARCHITECT. THE ARCHITECT SHOULD BE GIVEN ADVANCE NOTICE TO ALLOW ADEQUATE TIME TO REVIEW AND EVALUATE EACH OF THE CONTRACTOR'S PROPOSALS.

29. SAFETY OSHA AND LABOR LAWS :

29.1. THE STRUCTURE IS DESIGNED TO BE SELF-SUPPORTING AND STABLE AFTER THE BUILDING IS FULLY COMPLETED. IT IS THE CONTRACTOR'S SOLE RESPONSIBILITY TO DETERMINE ERECTION PROCEDURE AND SEQUENCE AND INSURE THE SAFETY OF THE BUILDING AND ITS COMPONENT PARTS DURING ERECTION. THIS INCLUDES THE ADDITION OF WHATEVER SHORING, TEMPORARY BRACING, ETC. THAT MAY BE NECESSARY. SUCH MATERIAL SHALL REMAIN THE CONTRACTOR'S PROPERTY AFTER COMPLETION OF THE PROJECT.

29.2. THE STRUCTURAL ENGINEER/ARCHITECT OF RECORD DOES NOT POSSES, NOR PRESUMES TO POSSES ANY KNOWLEDGE OR EXPERTISE IN MATTERS TO JOB SITE EMPLOYEE SAFETY, OSHA OR LABOR LAW REQUIREMENTS FOR A CONSTRUCTION PROJECT. SAFETY AND COMPLIANCE WITH OSHA AND LABOR LAWS ARE THE ABSOLUTE RESPONSIBILITY OF THE GENERAL CONTRACTOR AND THOSE CONSULTANTS HE/SHE HIRES TO ADDRESS THESE MATTERS. THE STRUCTURAL ENGINEER/ARCHITECT OF RECORD SPECIALIZES IN STRUCTURAL DESIGN/ARCHITECTURE ONLY, AND THE BOARD OF PROFESSIONAL REGULATION FORBIDS HIM/HER FROM ASSUMING RESPONSIBILITY OUTSIDE HIS/HER AREA OF EXPERTISE

141 GRAND AVE

141 GRAND AVENUE
CORAL GABLES, FL 33133

INDEX OF DRAWINGS	
SHEET NO.	SHEET NAME
GENERAL	
G.000	COVER SHEET
G.101	GENERAL INFORMATION
LIFE SAFETY	
LS.100	LIFE SAFETY PLANS
ARCHITECTURAL	
A.100	PROPOSED FLOORPLAN
A.101	PARTITION FLOORPLAN
A.102	REFLECTED CEILING PLAN
A.200	BUILDING ELEVATIONS
A.201	BUILDING ELEVATIONS
A.300	ENLARGED PLANS
A.400	ADA DETAILS
A.401	ADA DETAILS
A.500	PARTITION WALL TYPES
A.501	WINDOW & DOOR SCHEDULES
D.100	DEMO FLOORPLANS
PLUMBING	
P.100	WATER DISTRIBUTION AND SANITARY FLOOR PLANS
P.200	PLUMBING NOTES AND DETAILS
ELECTRICAL	
E.100	ELECTRICAL FIRST AND SECOND FLOOR PLANS
E.101	ELECTRICAL FIRST AND SECOND FLOOR PLANS
E.102	ELECTRICAL ROOF PLAN
E.200	ELECTRICAL NOTES AND DETAILS
MECHANICAL	
M.100	MECHANICAL FIRST AND SECOND FLOOR PLAN
M.101	MECHANICAL ROOD PLANS
M.200	MECHANICAL NOTES AND DETAILS

SYMBOLS LEGEND

Room name 101	ROOM INDICATOR		CALLOUT INDICATOR		FINISH INDICATOR
	BUILDING ELEVATION INDICATOR		BUILDING SECTION INDICATOR		DOOR INDICATOR
	INTERIOR ELEVATION INDICATOR		WALL SECTION INDICATOR		WINDOW/STOREFRONT INDICATOR
	GRID INDICATOR		BOTTOM OF CEILING HEIGHT INDICATOR		WALL TYPE INDICATOR
	PROPERTY LINE				

ARCHITECT

McKENZIE CONSTRUCTION, LLC
GILBERT ATICK FL AR98145

2247 NW 17 AVENUE
MIAMI, FL 33142
P. 786.412.7341

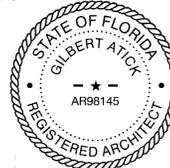

Printed copies of this document are not considered signed and sealed and the signature must be verified on any electronic copies.

MEP ENGINEER

RCI ENGINEERING INC.
5230 S. UNIVERSITY DR. SUITE 106
DAVIE, FL 33328
P. 954.680.2690

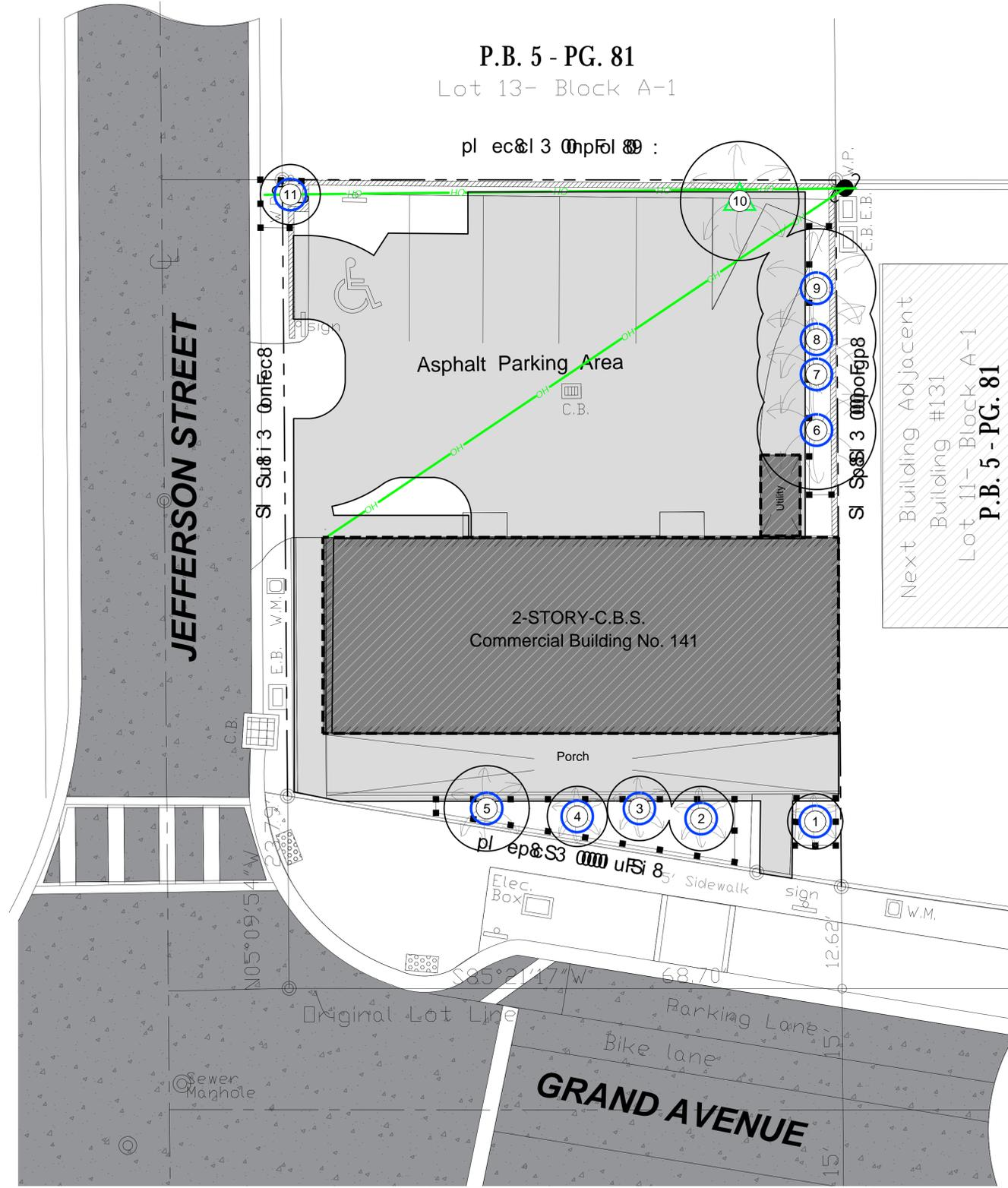
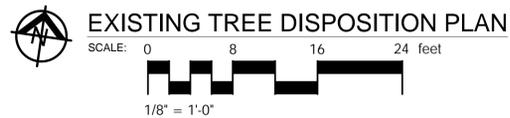

EXISTING TREE DISPOSITION LIST								
No.	Common Name	Scientific Name	Diameter (in)	Height (ft)	Spread (ft)	Condition	Disposition	Comments
1	Solitaire Palm	<i>Pychosperma elegans</i>	6	24	6	Fair	Remain	Double palm
2	Solitaire Palm	<i>Pychosperma elegans</i>	3	25	8	Fair	Remain	
3	Solitaire Palm	<i>Pychosperma elegans</i>	6	26	8	Fair	Remain	Double palm
4	Solitaire Palm	<i>Pychosperma elegans</i>	3	23	7	Fair	Remain	
5	Solitaire Palm	<i>Pychosperma elegans</i>	6	24	10	Fair	Remain	Double palm
6	Cabbage Palm	<i>Sabal palmetto</i>	12	27	13	Fair	Remain	
7	Cabbage Palm	<i>Sabal palmetto</i>	11	17	12	Fair	Remain	Double palm
8	Cabbage Palm	<i>Sabal palmetto</i>	12	13	11			
9	Cabbage Palm	<i>Sabal palmetto</i>	12	13	11	Fair	Remain	
10	Cabbage Palm	<i>Sabal palmetto</i>	11	17	12		Transplant	
11	Gumbo Limbo	<i>Bursera simaruba</i>	11	16	8	Fair	Remain	
TOTAL PROPOSED CANOPY LOSS (in square feet)								

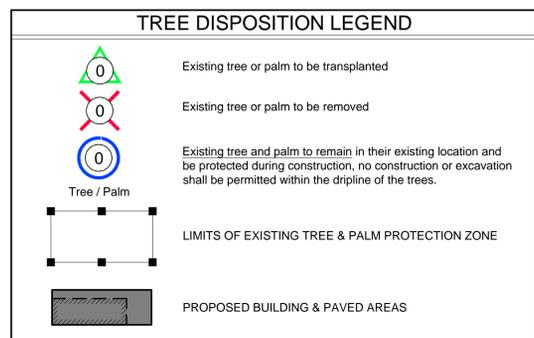

Sunshine811
 Call 811 or www.sunshine811.com two full business days before digging to have utilities located and marked.
Check positive response codes before you dig!

ALL LANDSCAPE DATA INC
 Landscape (Architecture + Plant Information)
 (305) 303 7069 / 4459 NW 97 CT.
 Doral, FL 33178
 www.alllandscapedata.net
 www.alllandscapedata.com

DERICK LANGE
 Landscape Architect LA666705
 ISA Certified Arborist FL439A

REVISIONS:
 City Comments #1 06-02-23

PROJECT NAME
**141 GRAND AVENUE,
 CORAL GABLES, FLORIDA, 33133**

SHEET INFORMATION:
 Drawing Size 24x36
 Project #: 2023-05-62 CE
 Drawn By: LA
 Checked By: DL
 Title:
**EXISTING TREE
 DISPOSITION PLAN**
 Sheet Number:
L-01
 Date: - June 30, 2023

PLANT SCHEDULE

TREES	CODE	QTY	BOTANICAL NAME	COMMON NAME	CONT	DBH	HGT	SRD	REMARKS
	CRO	3	Clusia rosea	Autograph Tree	FG/BB	4"	16' OA	4'-6'	Native tree- Very Drought Tolerant
	KRF	2	Krugiodendron ferreum	Black Ironwood	65 gal	3"-4"	12' OA	8'-10'	Florida Native - Miami-Dade Landscape Manual - Drought Tolerant - 5' CT
FLOWERING TREES	CODE	QTY	BOTANICAL NAME	COMMON NAME	CONT	DBH	HGT	SRD	REMARKS
	COS	2	Cordia sebestena	Orange Geiger	FG	1.5"-2"	8' OA	5'	Florida Native - Miami-Dade Landscape Manual - Drought Tolerant - Salt Tolerant
SHRUBS	CODE	QTY	BOTANICAL NAME	COMMON NAME	CONT	HGT	SRD		
	PSA	10	Pennisetum setaceum 'Alba'	White Leaved Fountain Grass	3 gal	2'	2'		Drought Tolerant - Miami-Dade Landscape Manual
	TFL	18	Tripsacum floridanum	Florida Gamagrass	3 gal.	2'	2'		Florida Native
LARGE SHRUBS	CODE	QTY	BOTANICAL NAME	COMMON NAME	CONT	HGT	SRD		
	CUV	27	Coccoloba uvifera	Sea Grape	15 gal.	5' OA	3.5'		Bush - Florida Native
SHRUB AREAS	CODE	QTY	BOTANICAL NAME	COMMON NAME	CONT	HGT	SRD	SPACING	
	CIR	59	Chrysobalanus icaco 'Red Tip'	Red Tip Cocoplum	3 gal	18"-24" OA	18"-24"	20" o.c.	Florida Native
	CRN	41	Clusia rosea 'Nana'	Dwarf Pitch Apple	3 gal.	2'	18"	20" o.c.	Florida Native - Miami-Dade Landscape Manual - Drought Tolerant
	NFA	15	Nephrolepis biserrata	Macho Fern	7 gal.	3"	20"	20" o.c.	Florida Native - Miami-Dade Landscape Manual
	JMC	27	Stachytarpheta jamaicensis	Blue Porterweed	3 gal.	2'	2'	24" o.c.	Florida Native - Drought Tolerant
	ZPU	60	Zamia pumila	Coontie	3 gal.	2'	18"	20" o.c.	Florida Native - Miami-Dade Landscape Manual
GROUND COVERS	CODE	QTY	BOTANICAL NAME	COMMON NAME	CONT	HGT	SRD	SPACING	
	ELI	47	Emodea littoralis	Golden Creeper	3 gal.	1'	1.5'	15" o.c.	
	FIP	33 sf	Ficus pumila	Creeping Fig	1 gal.				



Sunshine811
 Call 811 or www.sunshine811.com two full business days before digging to have utilities located and marked.
 Check positive response codes before you dig!

ALL LANDSCAPE DATA INC
 Landscape (Architecture + Plant Information)
 (305) 303 7069 / 4459 NW 97 CT.
 Doral, FL 33178
 www.alllandscapedata.net
 www.alllandscapedata.com

DERICK LANGEL
 Landscape Architect LA666705
 ISA Certified Arborist FL439A

REVISIONS:
 City Comments #1 06-02-23

PROJECT NAME
 141 GRAND AVENUE,
 CORAL GABLES, FLORIDA, 33133

SHEET INFORMATION:
 Drawing Size 24x36
 Project #: 2023-05-62 CE
 Drawn By: LA
 Checked By: DL
 Title:
 LANDSCAPE SCHEDULE & IMAGES
 Sheet Number:
 L-03
 Date: - June 30, 2023

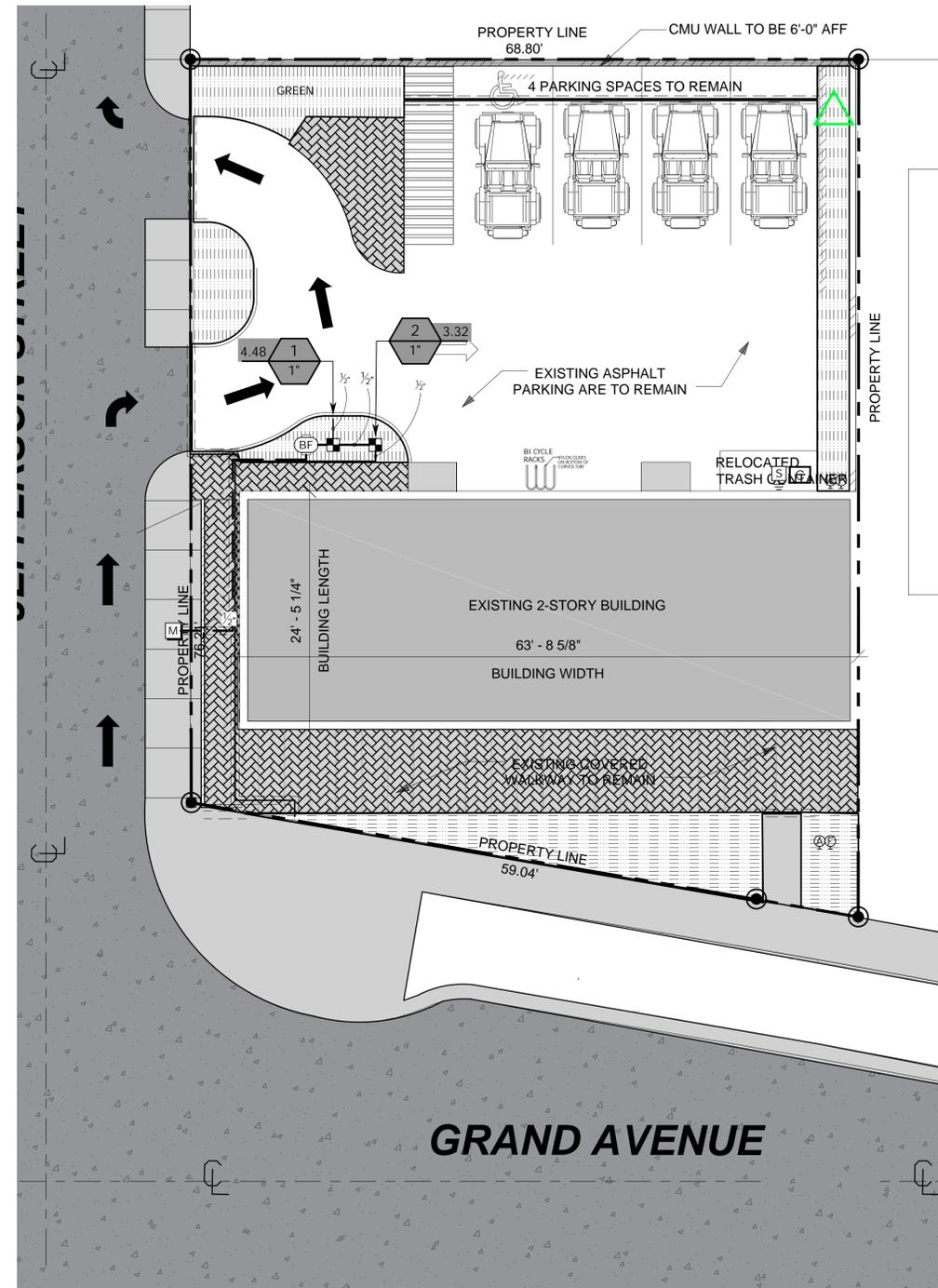

GENERAL
IRRIGATION SHALL BE INSTALLED IN ACCORDANCE WITH LOCAL CODES, CONTRACT DRAWINGS, CONTRACT SPECIFICATIONS, AND APPENDIX "F" OF THE FLORIDA BUILDING CODE.

IRRIGATION DESIGN BASED ON "PLANTING PLAN". CONTRACTOR SHALL REFER TO THIS PLAN TO COORDINATE SPRINKLER LOCATIONS AND PIPE ROUTING WITH NEW AND EXISTING PLANT LOCATIONS.

THIS PLAN SHALL BE USED AS A GUIDE ONLY. IRRIGATION SHALL BE INSTALLED TO MATCH ON SITE CONDITIONS AND TO OVERCOME THE INHERENT INACCURACIES THAT RESULT WHEN DESIGNING FROM BASE PLANS.

THIS IRRIGATION HAS BEEN DESIGNED AS A TYPICAL BLOCK VALVE TYPE USING TORO SPRINKLERS, IN-LINE VALVES AND CONTROL SYSTEM. A RAIN SENSOR SHALL BE INSTALLED TO CONSERVE WATER.

IRRIGATION SHALL BE INSTALLED AND MAINTAINED TO MINIMIZE UNDESIRABLE OVERTHROW ONTO PAVEMENT, SIDEWALKS, AND BUILDINGS.

CONTRACTOR SHALL VISIT THE SITE TO BECOME FAMILIAR WITH SITE CONDITIONS, AND SHALL REFER TO THE PLANS FOR ADDITIONAL INFORMATION.

TO ENSURE PROPER OPERATION, SOURCE SIZE, VALVE SIZES, ZONE CAPACITIES, AND SPRINKLER, PIPE AND WIRE SIZES, AND INSTALLATION NOTES AND DETAILS SHALL BE FOLLOWED AS SHOWN.

CONTRACTOR IS TO PROVIDE AN AS-BUILT DRAWING OF THE IRRIGATION SYSTEM TO THE OWNER AND LANDSCAPE ARCHITECT.

PIPING
PIPE ROUTING IS SCHEMATIC ONLY AND SHALL BE ADJUSTED FOR ON SITE CONDITIONS.

PIPE SHALL BE INSTALLED IN ACCORDANCE WITH LOCAL CODES, SECTION "F" OF THE FLORIDA BUILDING CODE, AND PIPE MANUFACTURER'S INSTRUCTIONS.

PIPE ROUTED UNDER HARDSCAPED AREAS SHALL BE SLEEVED IN SCH 40 PVC. EACH SLEEVE SHALL BE: (1) BURIED TO A MINIMUM DEPTH OF 24", (2) TWO PIPE SIZES LARGER THAN CARRIER PIPE, AND (3) EXTENDED 3" BEYOND HARDSCAPED AREA ON EACH END. CONTRACTOR SHALL REFER TO LOCATION OF EXISTING SLEEVES.

PIPE SIZED TO LIMIT FLOW VELOCITIES TO 5 FEET/SECOND AND TO LIMIT FRICTION LOSS IN THE PIPING NETWORK.

PIPE SHALL BE INSTALLED AT SUFFICIENT DEPTH BELOW GROUND TO PROTECT IT FROM HAZARD SUCH AS VEHICULAR TRAFFIC OR ROUTINE OCCURRENCES WHICH OCCUR IN THE NORMAL USE AND MAINTENANCE OF THE PROPERTY. DEPTHS OF COVER SHALL MEET OR EXCEED SCS CODE 430-DD. REFER TO THE APPLICABLE DETAIL FOR ADDITIONAL INFORMATION.

BACKFILL SHALL BE OF SUITABLE MATERIAL, FREE OF ROCKS, STONES, AND OTHER DEBRIS THAT WOULD DAMAGE IRRIGATION SYSTEM COMPONENTS.

A GATE VALVE SHALL BE INSTALLED FOR ISOLATION. THIS VALVE SHALL BE TO LINE SIZE AND INSTALLED IN A VALVE BOX. POROUS MATERIAL SHALL BE INSTALLED PER BOX TO PROMOTE DRAINAGE.

SPRINKLERS
SPRINKLER LOCATIONS ARE SCHEMATIC ONLY AND SHALL BE ADJUSTED FOR LANDSCAPING, FENCES, SITE LIGHTING, PREVAILING WIND, MOUNDING, ETC., TO ENSURE PROPER COVERAGE WITH MINIMAL UNDESIRABLE OVERTHROW. A PRIME OBJECTIVE SHALL BE TO ELIMINATE OVERTHROW ONTO PAVEMENT, SIDEWALKS, AND THE RESIDENCE.

PDP-UP TYPE LOCATED IN SDD, MULCH, AND GROUND COVERS SHALL BE INSTALLED ON FLEXIBLE SWING JOINTS CONSISTING OF THICKWALLED POLY PIPE AND 1/2" INSERT ELBOWS.

EACH SPRINKLER SHALL BE EQUIPPED WITH THE APPROPRIATE PRECISION SPRAY NOZZLE AND SHALL HAVE THE X-FLOW FEATURE.

ADJUSTMENT FEATURES OF SPRINKLERS SPECIFIED SHALL BE UTILIZED TO ENSURE PROPER COVERAGE WITH MINIMAL UNDESIRABLE OVERTHROW. LOW ANGLE, FLAT SPRAY, AND ADJUSTABLE ARC NOZZLES SHALL BE USED TO MINIMIZE OVERTHROW.

SPRINKLERS LOCATED ADJACENT TO HARDSCAPED AREAS SHALL BE INSTALLED AWAY FROM HARDSCAPED AREAS TO MINIMIZE OVERTHROW AND THE CHANCE OF DAMAGE BY VEHICLES, PEDESTRIANS, AND LAWN MAINTENANCE PERSONNEL. AS A GENERAL RULE, 6" POP-UP SPRAY HEADS SHALL BE INSTALLED IN 4", SHRUB HEADS AND 12" POP-UP SPRAY HEADS SHALL BE INSTALLED IN 12".

CONTROL SYSTEM
CONTROLLER SHALL BE INSTALLED IN ACCORDANCE WITH LOCAL CODES AND MANUFACTURER'S INSTRUCTIONS. PROPER GROUNDING EQUIPMENT SHALL BE PROVIDED.

CONTROLLER LOCATION SHALL BE APPROVED BY THE OWNER'S REPRESENTATIVE. A 110 VAC ELECTRIC SOURCE IS REQUIRED.

CONTROL LINES FROM AUTOMATIC CONTROLLER TO IN-LINE AUTOMATIC VALVES SHALL BE #14 AWG DIRECT BURIAL UF TYPE WHICH SHALL BE: (1) INSTALLED IN ACCORDANCE WITH LOCAL CODES, (2) INSTALLED IN SCH 40 PVC WIRE CONDUIT, (3) BURIED TO A MINIMUM DEPTH OF 15", (4) COLORED (CODED) TO FACILITATE TROUBLESHOOTING, AND (5) SPLICED MOSTLY AT VALVE LOCATIONS. SPLICES SHALL BE MADE WATERPROOF USING APPROVED METHODS. SPARE WIRES SHALL BE ROUTED FROM THE CONTROLLER IN ALL DIRECTIONS TO THE FARTHEST VALVES CONTROLLED.

AN INDIVIDUAL CONTROL WIRE SHALL BE ROUTED TO EACH VALVE AND VALVES WHICH OPERATE SIMULTANEOUSLY SHALL BE TIED TOGETHER AT THE CONTROLLER.

AUTOMATIC VALVE LOCATIONS ARE SCHEMATIC ONLY AND SHALL BE ADJUSTED FOR ON SITE CONDITIONS. EACH VALVE SHALL BE INSTALLED IN A VALVE BOX. A MINIMUM OF ONE CUBIC FOOT OF GRAVEL SHALL BE PROVIDED PER BOX TO PROMOTE DRAINAGE.

THE RAIN SENSOR SHALL BE INSTALLED IN ACCORDANCE WITH MANUFACTURER'S INSTRUCTIONS.

TIMING AND PRECIPITATION
TIMING OF EACH STATION SHALL BE SET IN THE FIELD TO MATCH LOCAL REQUIREMENTS. REFER TO ZONE SUMMARY CHART FOR RECOMMENDED RUN TIMES TO APPLY 1.0 INCHES/WEEK.

IRRIGATION SCHEDULE

SYMBOL	MANUFACTURER/MODEL/DESCRIPTION	QTY
■	Toro DZK-EZF-1-MF 1" Medium Flow Drip Control Valve Kit. With 1" EZ-Flo Plus Valve, Toro Y-Filter, and Medium-Flow Pressure Regulator and Fittings. 5gpm-20gpm.	2
⊕	Toro T-FCH-H-FIPT Flush Valve, plumbed to flush manifold at low point.	2
⊖	Toro T-YD-500-34 1/2" Air Vent- MIPT Air Release and Vacuum Relief Valve	2
▨	Area to Receive Dripline Toro RGP-412 Sub-Surface Pressure Compensating Landscape Dripline with ROOTGUARD technology. 1.00 GPH emitters at 12" O.C. Dripline laterals spaced at 18" apart, with emitters offset for triangular pattern.	467.1 l.f.
SYMBOL	MANUFACTURER/MODEL/DESCRIPTION	QTY
⊖	Febco 825Y 1" Reduced Pressure Backflow Preventer	1
C	Toro Controller EVO-04OD-SC 4 Station Outdoor Controller. With Smart Connect so Controller can communicate wirelessly with a number of add-on devices. Ideal for residential and light-commercial applications.	1
S	Toro Rain Sensor TWRS Wireless Rain Sensor Transmitter and Receiver. Mount Sensor Transmitter as noted or approved, mount Sensor Receiver next to Irrigation Controller as noted or approved, use controller power or optional transformer. Adjustable rain shut-off point.	1
M	Water Meter 1"	1
—	Irrigation Lateral Line: PVC Schedule 40 1/2"	60.4 l.f.
---	Irrigation Mainline: PVC Schedule 40 1/2"	39.3 l.f.
----	Pipe Sleeve: PVC Class 200 SDR 21	114.8 l.f.

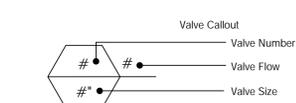

VALVE SCHEDULE

NUMBER	MODEL	SIZE	TYPE	GPM	WIRE	PSI	PSI @ POC	PRECIP
1	Toro DZK-EZF-1-MF	1"	Area for Dripline	4.48	48.1	40.0	54.9	1.07 in/h
2	Toro DZK-EZF-1-MF Common Wire	1"	Area for Dripline	3.32	48.1	42.3	56.2	1.07 in/h

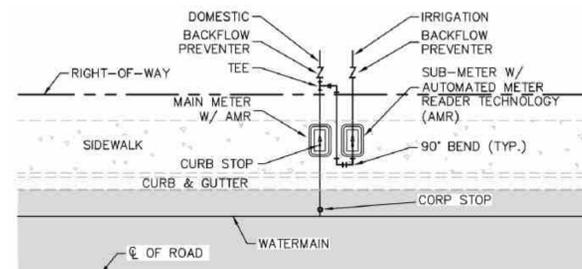

NOTES:

- MUST USE RECTANGULAR BOX TO ACCOMMODATE BOTH THE SUB-METER AND SHUT-OFF VALVE.
- MUST HAVE SHUT-OFF VALVE ON INLET SIDE BEFORE METER.
- MUST PLACE SUB-METER BOX WITHIN 5 FEET OF MAIN METER, EASILY ACCESSIBLE TO METER READER.
- MUST CALL METER SHOP AT 305-673-7681 WHEN INSTALLATION IS COMPLETED FOR FINAL INSPECTION IN ORDER TO OBTAIN SEWER CREDIT.
- SUB-METER CANNOT BE LARGER THAN THE DOMESTIC METER WATER SERVICE LINE.

2 SUB-METER INSTALLATION DETAIL

SCALE: N.T.S.

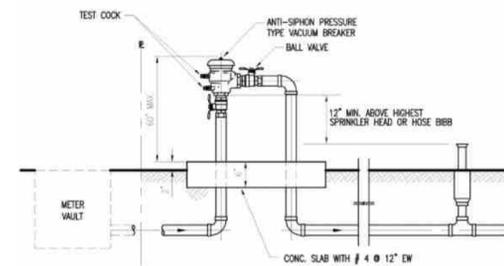
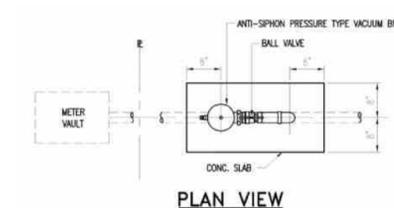

3 VACUUM BREAKER

N.T.S.

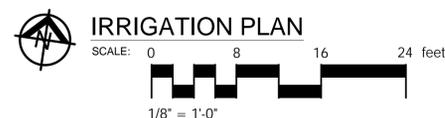

NOTES:

- THE ASSEMBLY SHALL BE INSTALLED WITH MINIMUM HORIZONTAL CLEARANCES OF 30 INCHES FREE FROM OBSTRUCTIONS IN ALL DIRECTIONS.
- GUARD POSTS SHALL BE INSTALLED IF THE ASSEMBLY IS EXPOSED TO POSSIBLE DAMAGE FROM VEHICULAR TRAFFIC, AS DETERMINED BY THE DEPARTMENT.
- THE ASSEMBLY SHALL BE INSTALLED IN AN ACCESSIBLE LOCATION, APPROVED BY THE DEPARTMENT.
- PIPING SHALL BE SCHEDULE 40 BRASS OR TYPE K COPPER PIPE WITH THREADED FITTINGS IN ACCORDANCE WITH WASS CONSTRUCTION SPECIFICATIONS FOR DOMESTIC WATER MAINS. PVC PIPING IS NOT ACCEPTED BY WASS.
- THE DEPARTMENT SHALL HAVE UNRESTRICTED AND CONTINUOUS ACCESS TO THE VACUUM BREAKER ASSEMBLY.
- SEE SPECIFICATIONS AND CONTACT DEPARTMENT FOR CURRENTLY APPROVED TYPES OF BACKFLOW PREVENTION ASSEMBLIES AND PRESSURE VACUUM BREAKERS (SEE WS 4.18 SHEET 4 OF 4)

1 IRRIGATION NOTES

SCALE: NTS

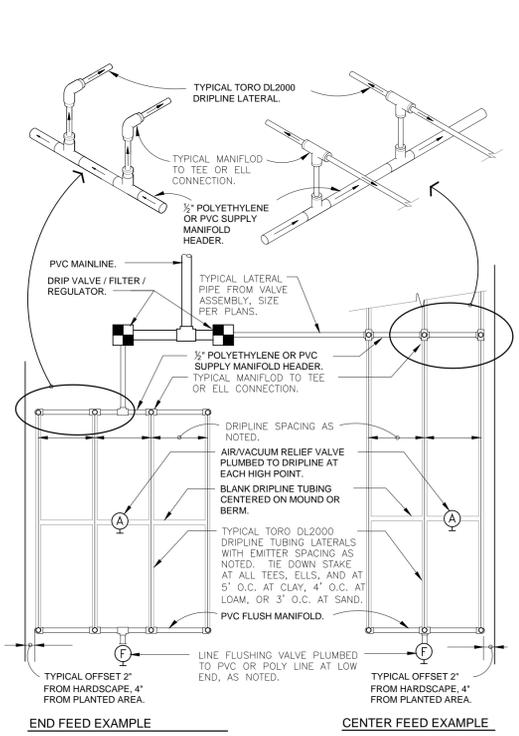

MAXIMUM RECOMMENDED LENGTH OF RUN AT 0% SLOPE

DRIPLINE TYPE	FLOW RATE	EMITTER SPACING	15 PSI	25 PSI	30 PSI	40 PSI
RPG212	0.53 GPH	12"	250'	360'	400'	460'
RPG218	0.53 GPH	18"	350'	515'	565'	650'
RPG412	1.0 GPH	12"	160'	240'	260'	300'
RPG418	1.0 GPH	18"	240'	340'	375'	430'

FLOW RATE PER 100 LINEAR FEET @ 20 PSI

DRIPLINE TYPE	FLOW RATE	EMITTER SPACING	ACTUAL FLOW / 100 FT. GPM	/ 100 FT. GPM
RPG212	0.53 GPH	12"	53.00	0.88
RPG218	0.53 GPH	18"	35.33	0.59
RPG412	1.0 GPH	12"	102.00	1.70
RPG418	1.0 GPH	18"	67.99	1.13

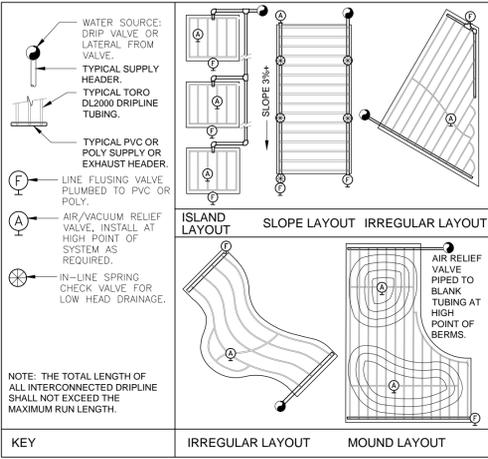

328413.56-49

1 TORO DL2000 DRIPLINE
3" = 1'-0"

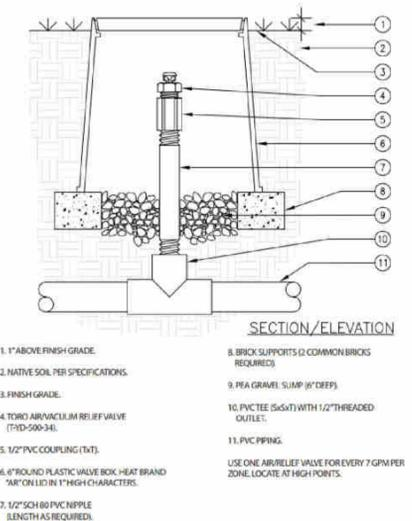

4 1/2" AIR/VACUUM RELIEF VALVE
N.T.S.

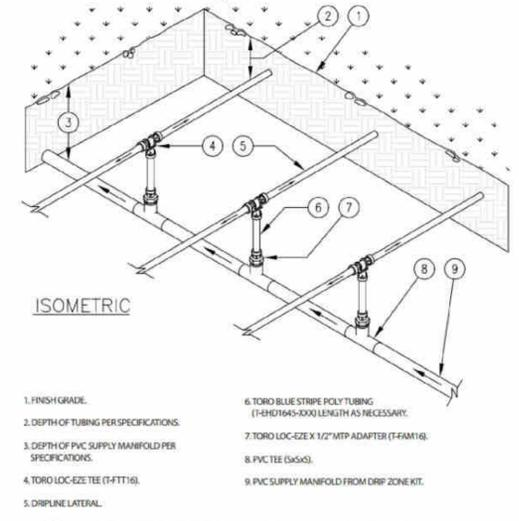

5 CENTER-FEED SUPPLY-MANIFOLD
N.T.S.

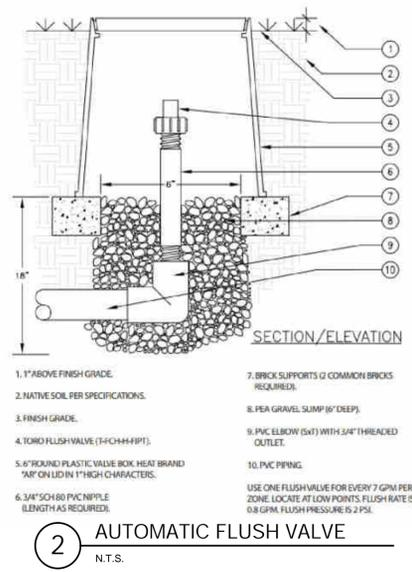

2 AUTOMATIC FLUSH VALVE
N.T.S.

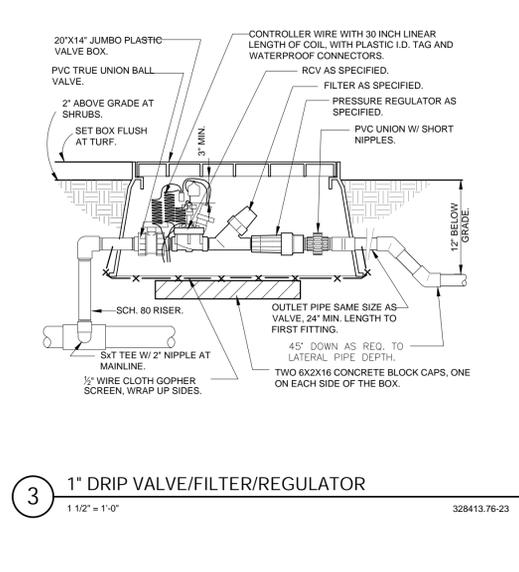

3 1" DRIP VALVE/FILTER/REGULATOR
1 1/2" = 1'-0" 328413.76-23

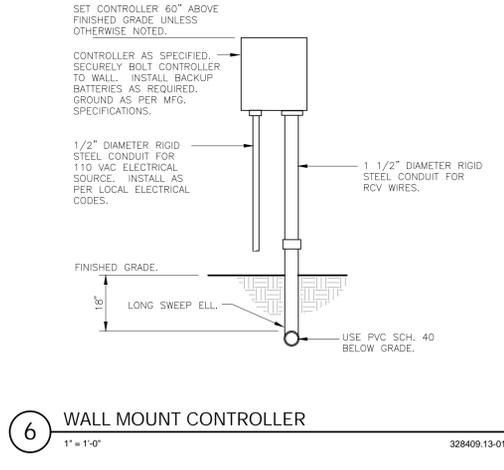

6 WALL MOUNT CONTROLLER
1" = 1'-0" 328409.13-01

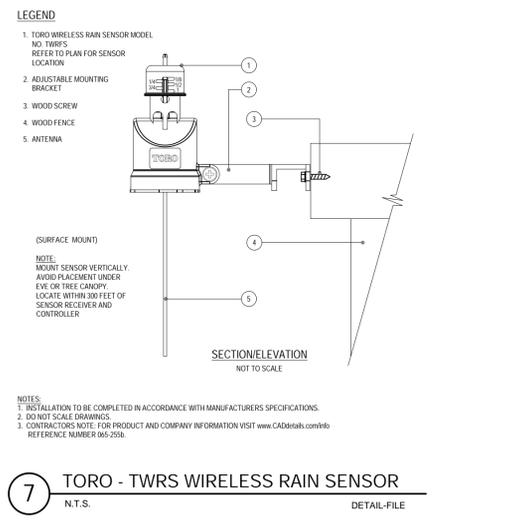

7 TORO - TWRS WIRELESS RAIN SENSOR
N.T.S. DETAIL-FILE

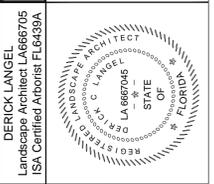

REVISIONS:

NO.	DESCRIPTION	DATE
1	06-02-23	City Comments #1

PROJECT NAME

**141 GRAND AVENUE,
CORAL GABLES, FLORIDA, 33133**

SHEET INFORMATION:

Drawing Size	24x36
Project #:	2023-05-62 CE
Drawn By:	LA
Checked By:	DL
Title:	IRRIGATION DETAILS
Sheet Number:	IR-02
Date:	June 30, 2023

Review Comments

Wednesday, August 30, 2023

2023008352 - Sparks Learning

Please submit a response to comments document along with the resubmittal addressing the comments below.

TRAFFIC ENGINEERING DIVISION COMMENTS:

The proposed Sparks Learning is a private school that will occupy an existing office building at 141 Grand Avenue, Coral Gables, Florida. The school proposes a maximum enrollment of 35 students.

The Department of Transportation and Public Works Traffic Engineering Division has reviewed the subject application and has no objections subject to the following conditions:

- **The school site parking lot shall be used only for drop-off/pick-up operations.**
- **Offsite Parking A is west of the school and will only be used for faculty and employee parking. Student drop-off/pick-up shall not occur at Offsite Parking A.**
- **Parents who use Offsite Parking B shall walk their children between this area and the school at all times.**
- **The school will not allow any students to walk or ride a bicycle to and from school. This will be enforced by the school.**
- **Any gates installed at entrance and exit driveways must open at least 30 minutes before the arrival/dismissal times to allow early parents to stage on-site.**
- **Exit driveways must comply with clear sight visibility requirements for both pedestrians and vehicular traffic.**
- **The school is eligible for school speed zone designation. School is required to install any required improvements along Grand Avenue and Jefferson Street. The school speed zone times shall be coordinated with the existing G W Carver Elementary School speed zone times. Contact DTPW-TED for information relating to recent Florida Department of Transportation (FDOT) Speed Zoning updates as they relate to school zones.**

Please contact our office at (305) 375-2030 for any further questions.

Thank you.



August 28, 2023; Revised September 7, 2023

Edward Baker
Berger Singerman
1450 Brickell Avenue, Suite 1900
Miami, FL 33131

Re: Trip Generation Statement
Sparks Learning, Inc.
Project No.: 2023030081

Dear Mr. Baker:

Vala Group, Inc. prepared this traffic-generation statement, Traffic Operations Plans (TOP), and the County TOP form for the Sparks Learning, Inc. private school that will occupy an existing office building at 141 Grand Avenue, Coral Gables, Florida (see **Figure 1** below). We prepared trip-generation estimates for the proposed development and determined that it will only generate 32 more net-new, AM peak-hour trips than the existing development it will replace. This letter report includes trip-generation calculations, TOP, and TOP form for the proposed private school.

Figure 1 – Site Location Aerial Photograph



Project Description

The project will operate a 35-student third through eight grade private school within the former office building. The development parcel (Folio No.: 03-4120-006-0950) is approximately 0.12 acres and is within the county-designated Urban Infill Area. The site

has one two-way driveway connection to Jefferson Street. No driveway connections are proposed on Grand Avenue. **Attachment A** contains a copy of the site plan and property-appraiser data. The amount of building area will not be changed. The school will operate with classes beginning at 8:00 AM and ending at 3:00 PM during weekdays. The school will operate with two teachers and bus service will not be provided. Primer Microschools are schools of between 15-35 students led in person by an educator, either a former teacher or homeschooler, who acts as the leader of the school. At specific points each day, students log on and attend virtual classes with Primer Teachers for various core subjects.

Trip Generation Analysis

The proposed private school is expected to generate 116 daily, 32 AM peak hour, and 5 PM peak hour, net-new vehicle trips. We prepared trip estimates, summarized in **Table 1**, using equations from the 11th Edition of the Institute of Transportation Engineers' *Trip Generation Manual*. **Attachment B** contains the trip-generation calculations and ITE data. We used the K-8 Private School ITE land use category because it is the most closely related land use to the proposed school.

Table 1 – Trip Generation Estimates

Land Use		Size	Daily	Weekday Morning Peak Hour			Weekday Afternoon Peak Hour		
				In	Out	Total	In	Out	Total
Existing	Small Office Building	1,931 SF	28	2	1	3	1	3	4
Proposed	Private School (K-8)	35 Students	144	20	15	35	4	5	9
Net New Trips (Proposed less Existing)			116	18	14	32	3	2	5

Based on 11th Edition of ITE Trip Generation Manual

Traffic Operations Plan and Form

We prepared TOPs for the onsite and offsite operations of the proposed school. The first plan sheet (TOP-1.0) shows access and exit points for vehicles, pedestrians, and bicyclists during the arrival and dismissal times at the proposed school. The second sheet (TOP 2.0) shows the pedestrian route from the offsite parking area. Offsite Area A is west of the school and will only be used for faculty and employee parking. Offsite Area B is east of the school and will only be used for parents during school arrival and dismissal times. The school will not allow any of their students to walk or ride a bicycle to and from school and will include this statement in their parent/student handbook. Parents who use Offsite Area B will be allowed to walk their children between this area and the school.

Offsite Area A is west of the school at 213 and 215 Grand Avenue and will provide three standard spaces and one ADA parking space. Offsite Area will only be used as a parking area for school faculty and employees. Offsite Area B is east of the school at 127 Grand Avenue and will provide four standard parking spaces. Offsite Area B will operate similar to a daycare where parents park in a parking space to pick up and drop off their children. Drop-off and pick-up times will be staggered at the school and the Offsite Area B location to ensure that no vehicles are queued on public roads. The school will not utilize any on-

street parking spaces for pick-up, drop-off, or vehicle stacking purposes. Parents will be given a specific drop-off/pick-up time and location. **Attachment C** contains the TOPs. We included a copy of the County's TOP form in **Attachment D**.

There are school zones on Grand Avenue west of the school and on Jefferson Street north and south of Grand Avenue. The existing school speed zone times are between 7:30 and 9:15 AM and between 1:45 and 4:15 PM (Wednesdays: 1:45 and 4:00 PM). Classes begin at 8:00 AM and end at 3:00 PM. Therefore, no timeframe modifications should be required because the existing timeframes are 30 minutes before and 30 minutes after commencement and dismissal times of the proposed school. The school agrees to coordinate with the County and install pavement markings and ground mounted traffic control devices to extend the existing school zone on Grand Avenue to include the Sparks Learning, Inc. school.

Conclusion

We prepared trip-generation calculations, TOPs, and County TOP form for the proposed Sparks Learning, Inc. private school and determined that it will not generate more than 32 AM peak hour net-new trips. Please contact me with any questions or comments.

Sincerely,
Vala Group, Inc.

John P. Kim, P.E.
Senior Project Manager

JPK/jgk

Attachments

- Attachment A – Site Plan & Property Appraiser Data
- Attachment B – Trip Generation Table & ITE Data
- Attachment C – Traffic Operations Plans
- Attachment D – County TOP Form



ATTACHMENT A
Site Plan & Property Appraiser Data



OFFICE OF THE PROPERTY APPRAISER

Summary Report

Generated On : 4/3/2023

Property Information	
Folio:	03-4120-006-0950
Property Address:	141 GRAND AVE Coral Gables, FL 33133-4839
Owner	141 GRAND LLC
Mailing Address	141 GRAND AVE CORAL GABLES, FL 33133 USA
PA Primary Zone	6400 COMMERCIAL - CENTRAL
Primary Land Use	1813 OFFICE BUILDING - MULTISTORY : OFFICE BUILDING
Beds / Baths / Half	0 / 0 / 0
Floors	1
Living Units	0
Actual Area	1,931 Sq.Ft
Living Area	Sq.Ft
Adjusted Area	1,931 Sq.Ft
Lot Size	5,224 Sq.Ft
Year Built	2000



Assessment Information			
Year	2022	2021	2020
Land Value	\$705,240	\$705,240	\$705,240
Building Value	\$173,616	\$154,668	\$156,555
XF Value	\$12,773	\$12,930	\$13,089
Market Value	\$891,629	\$872,838	\$874,884
Assessed Value	\$891,629	\$872,838	\$833,500

Benefits Information				
Benefit	Type	2022	2021	2020
Non-Homestead Cap	Assessment Reduction			\$41,384

Note: Not all benefits are applicable to all Taxable Values (i.e. County, School Board, City, Regional).

Short Legal Description
MAC FARLANE HOMESTEAD PB 5-81
LOT 12 BLK 1A LESS BEG 23.79FT N
OF SW COR LOT 12 E59.04FT SELY
A/D 10.68FT S12.62FT W68.7FT
TO POB

Taxable Value Information			
	2022	2021	2020
County			
Exemption Value	\$0	\$0	\$0
Taxable Value	\$891,629	\$872,838	\$833,500
School Board			
Exemption Value	\$0	\$0	\$0
Taxable Value	\$891,629	\$872,838	\$874,884
City			
Exemption Value	\$0	\$0	\$0
Taxable Value	\$891,629	\$872,838	\$833,500
Regional			
Exemption Value	\$0	\$0	\$0
Taxable Value	\$891,629	\$872,838	\$833,500

Sales Information			
Previous Sale	Price	OR Book-Page	Qualification Description
08/31/2020	\$1,050,000	32085-2208	Qual by exam of deed
06/07/2017	\$1,000,000	30567-0281	Qual by exam of deed
06/28/2010	\$649,000	27350-4848	Qual by exam of deed
08/01/1999	\$21,000	18738-1017	Sales which are qualified

The Office of the Property Appraiser is continually editing and updating the tax roll. This website may not reflect the most current information on record. The Property Appraiser and Miami-Dade County assumes no liability, see full disclaimer and User Agreement at <http://www.miamidade.gov/info/disclaimer.asp>

Version:

ATTACHMENT B
Trip Generation Table & ITE Data

TRIP GENERATION ANALYSIS

DAILY

Land Use		ITE Code	Size	Trip Generation Rate	In	Out	Total Trips		
							In	Out	Total
Existing	Small Office Building	712	1,931 SF	T = 14.39 (X)	50%	50%	14	14	28
Proposed	Private School (K-8)	530	35 Students	T = 4.11 (X)	50%	50%	72	72	144
Net New Trips (Proposed less Existing)							58	58	116

MORNING PEAK HOUR

Land Use		ITE Code	Size	Trip Generation Rate	In	Out	Total Trips		
							In	Out	Total
Existing	Small Office Building	712	1,931 SF	T = 1.67 (X)	82%	18%	2	1	3
Proposed	Private School (K-8)	530	35 Students	T = 1.01 (X)	56%	44%	20	15	35
Net New Trips (Proposed less Existing)							18	14	32

AFTERNOON PEAK HOUR

Land Use		ITE Code	Size	Trip Generation Rate	In	Out	Total Trips		
							In	Out	Total
Existing	Small Office Building	712	1,931 SF	T = 2.16 (X)	34%	66%	1	3	4
Proposed	Private School (K-8)	530	35 Students	T = 0.26 (X)	46%	54%	4	5	9
Net New Trips (Proposed less Existing)							3	2	5



Small Office Building (712)

Vehicle Trip Ends vs: 1000 Sq. Ft. GFA
On a: Weekday

Setting/Location: General Urban/Suburban

Number of Studies: 21

Avg. 1000 Sq. Ft. GFA: 3

Directional Distribution: 50% entering, 50% exiting

Vehicle Trip Generation per 1000 Sq. Ft. GFA

Average Rate	Range of Rates	Standard Deviation
14.39	4.44 - 50.91	10.16

Data Plot and Equation

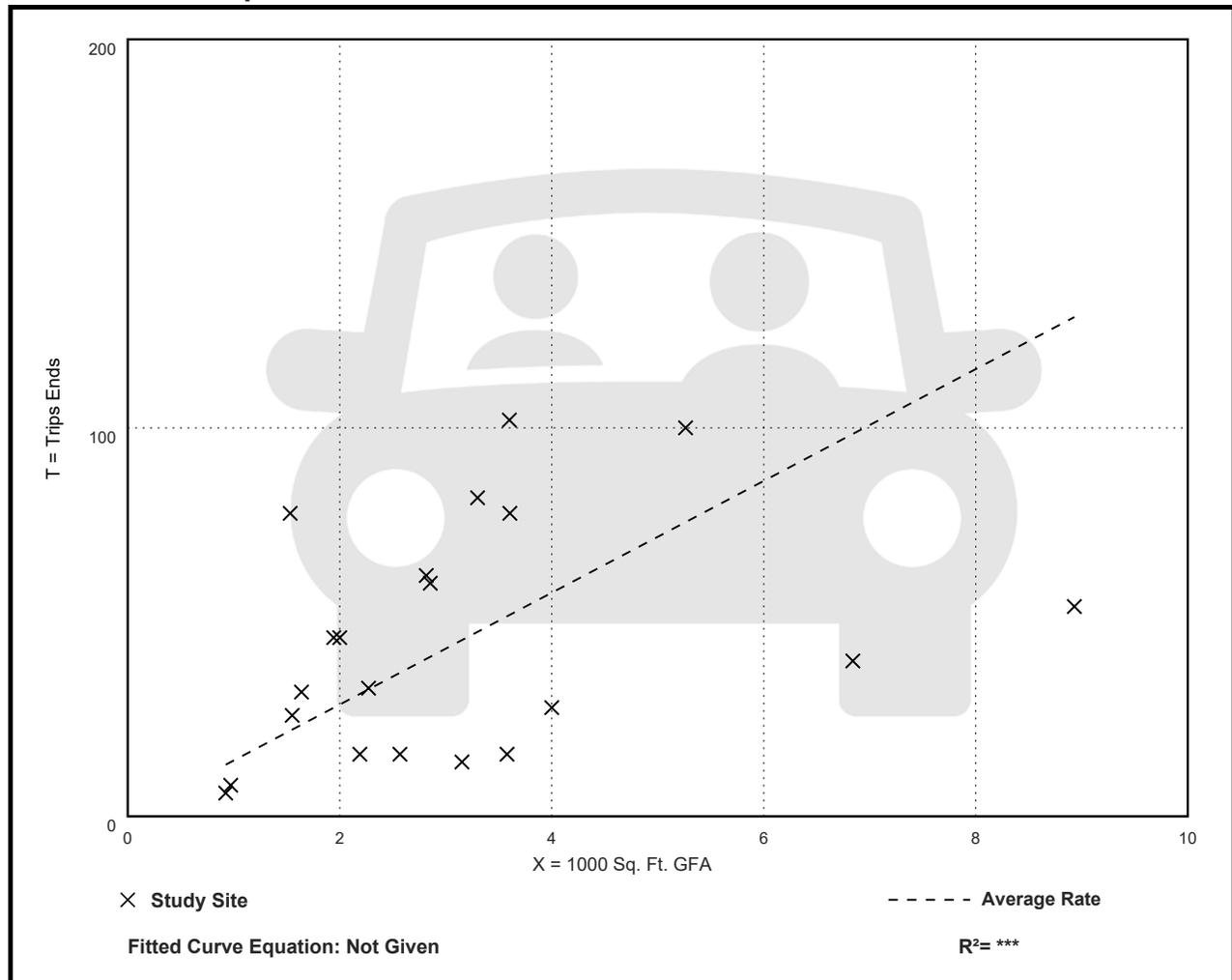

Small Office Building (712)

Vehicle Trip Ends vs: 1000 Sq. Ft. GFA

On a: Weekday,

Peak Hour of Adjacent Street Traffic,

One Hour Between 7 and 9 a.m.

Setting/Location: General Urban/Suburban

Number of Studies: 21

Avg. 1000 Sq. Ft. GFA: 3

Directional Distribution: 82% entering, 18% exiting

Vehicle Trip Generation per 1000 Sq. Ft. GFA

Average Rate	Range of Rates	Standard Deviation
1.67	0.76 - 4.12	0.88

Data Plot and Equation

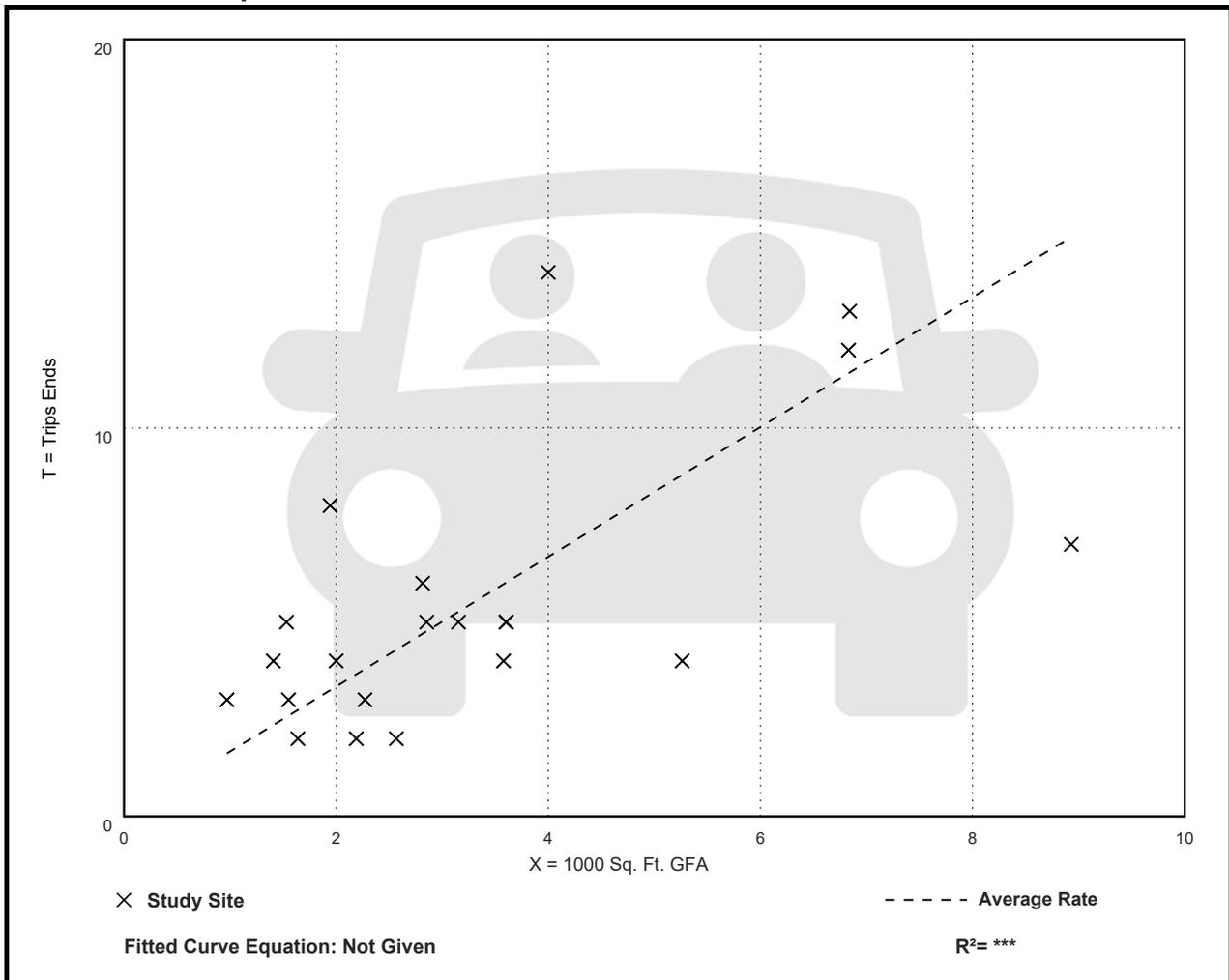

Small Office Building (712)

Vehicle Trip Ends vs: 1000 Sq. Ft. GFA

On a: Weekday,

Peak Hour of Adjacent Street Traffic,

One Hour Between 4 and 6 p.m.

Setting/Location: General Urban/Suburban

Number of Studies: 21

Avg. 1000 Sq. Ft. GFA: 3

Directional Distribution: 34% entering, 66% exiting

Vehicle Trip Generation per 1000 Sq. Ft. GFA

Average Rate	Range of Rates	Standard Deviation
2.16	0.56 - 5.50	1.26

Data Plot and Equation

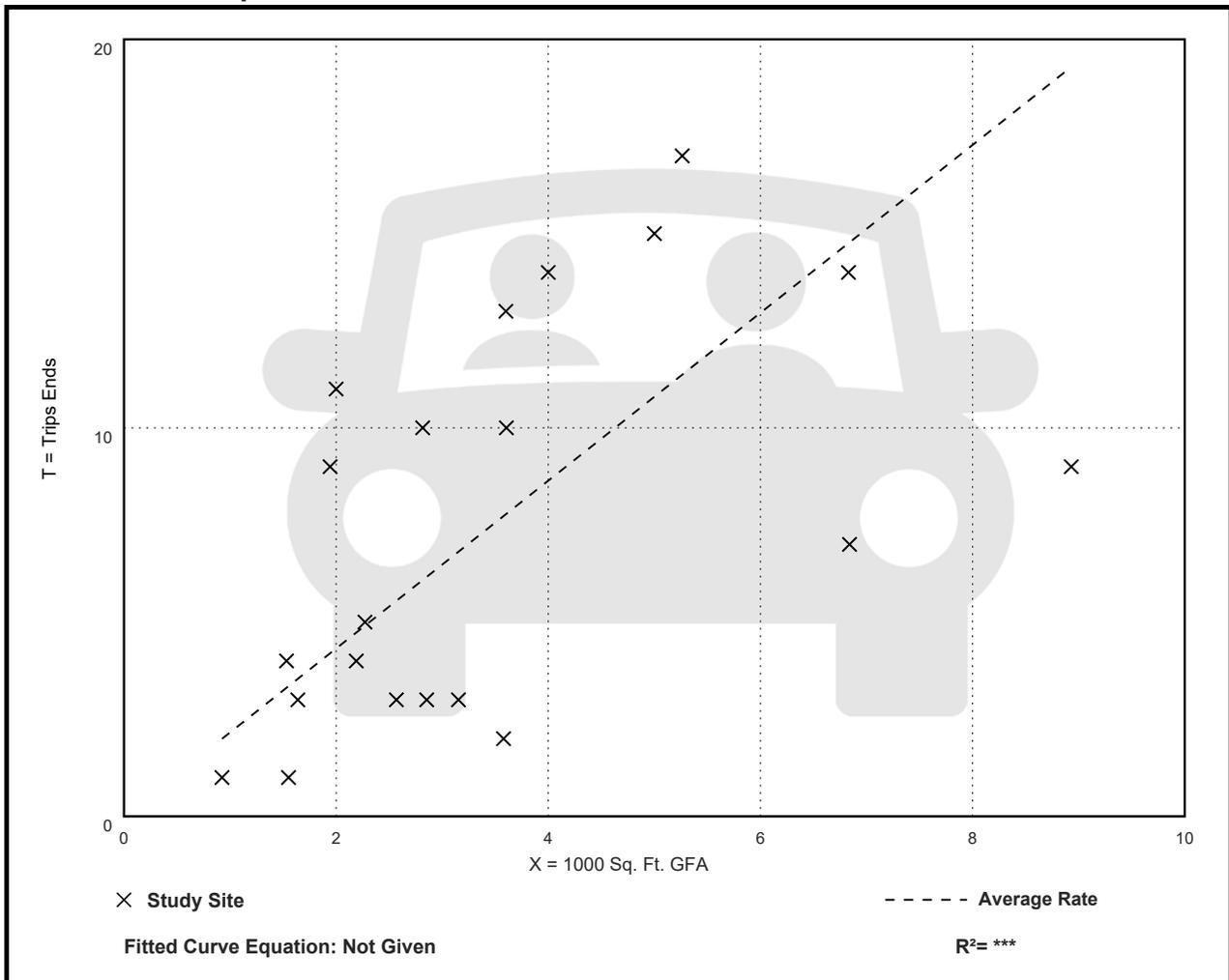

Private School (K-8) (530)

Vehicle Trip Ends vs: Students

On a: Weekday,

Peak Hour of Adjacent Street Traffic,

One Hour Between 7 and 9 a.m.

Setting/Location: General Urban/Suburban

Number of Studies: 14

Avg. Num. of Students: 409

Directional Distribution: 56% entering, 44% exiting

Vehicle Trip Generation per Student

Average Rate	Range of Rates	Standard Deviation
1.01	0.76 - 1.39	0.18

Data Plot and Equation

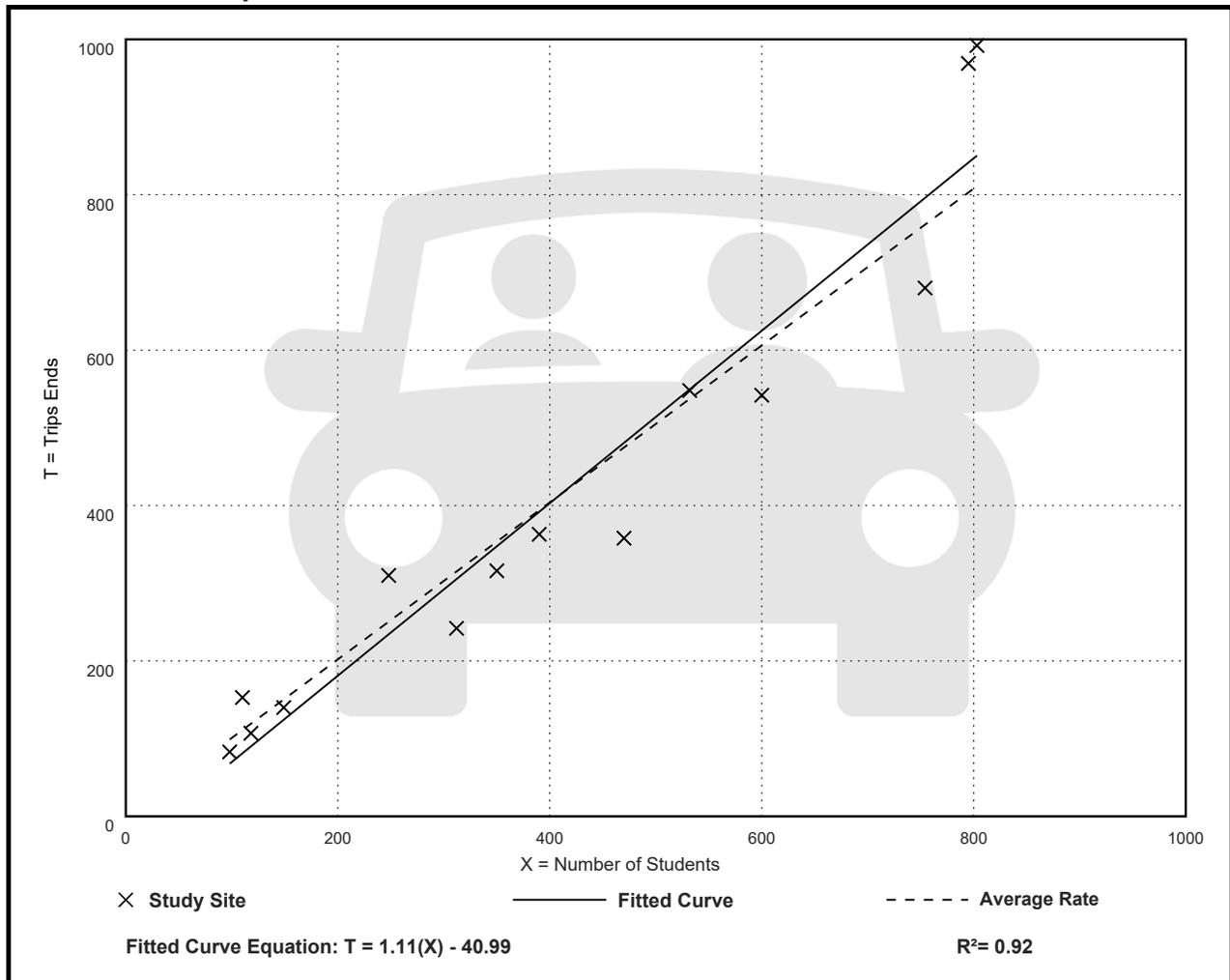

Private School (K-8) (530)

Vehicle Trip Ends vs: Students

On a: **Weekday,**

Peak Hour of Adjacent Street Traffic,

One Hour Between 4 and 6 p.m.

Setting/Location: General Urban/Suburban

Number of Studies: 5

Avg. Num. of Students: 420

Directional Distribution: 46% entering, 54% exiting

Vehicle Trip Generation per Student

Average Rate	Range of Rates	Standard Deviation
0.26	0.14 - 0.77	0.15

Data Plot and Equation

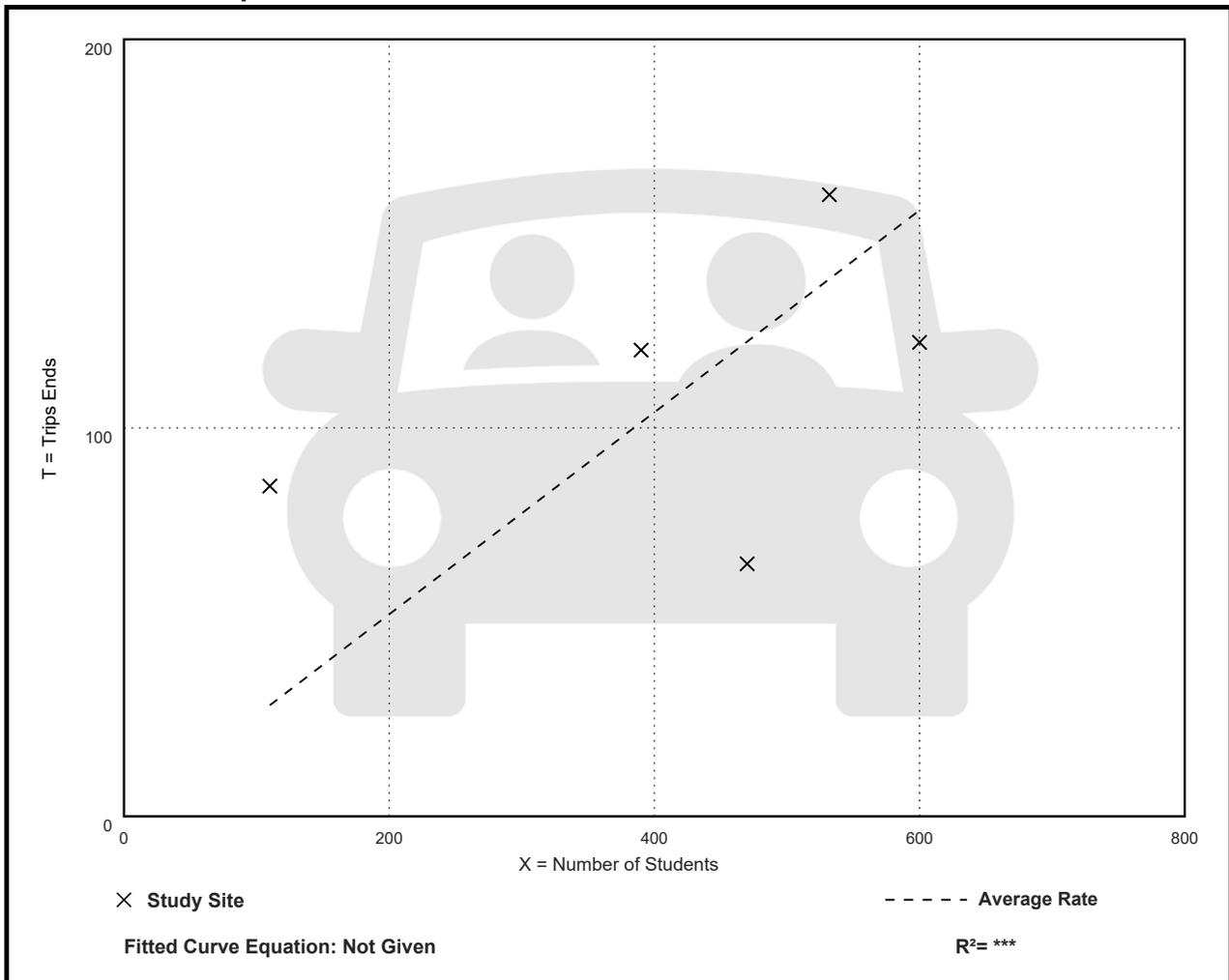

ATTACHMENT C
Traffic Operations Plan

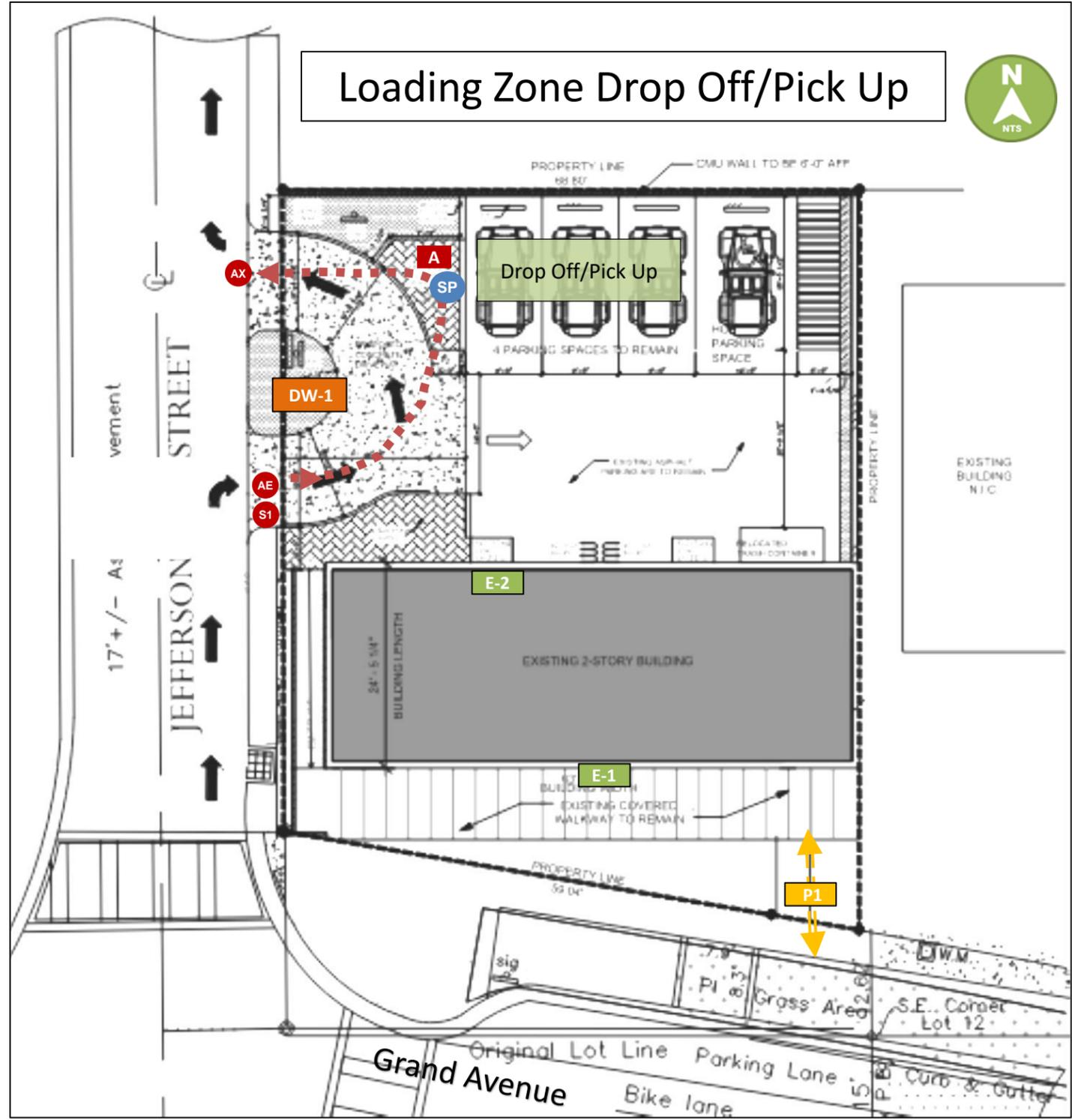
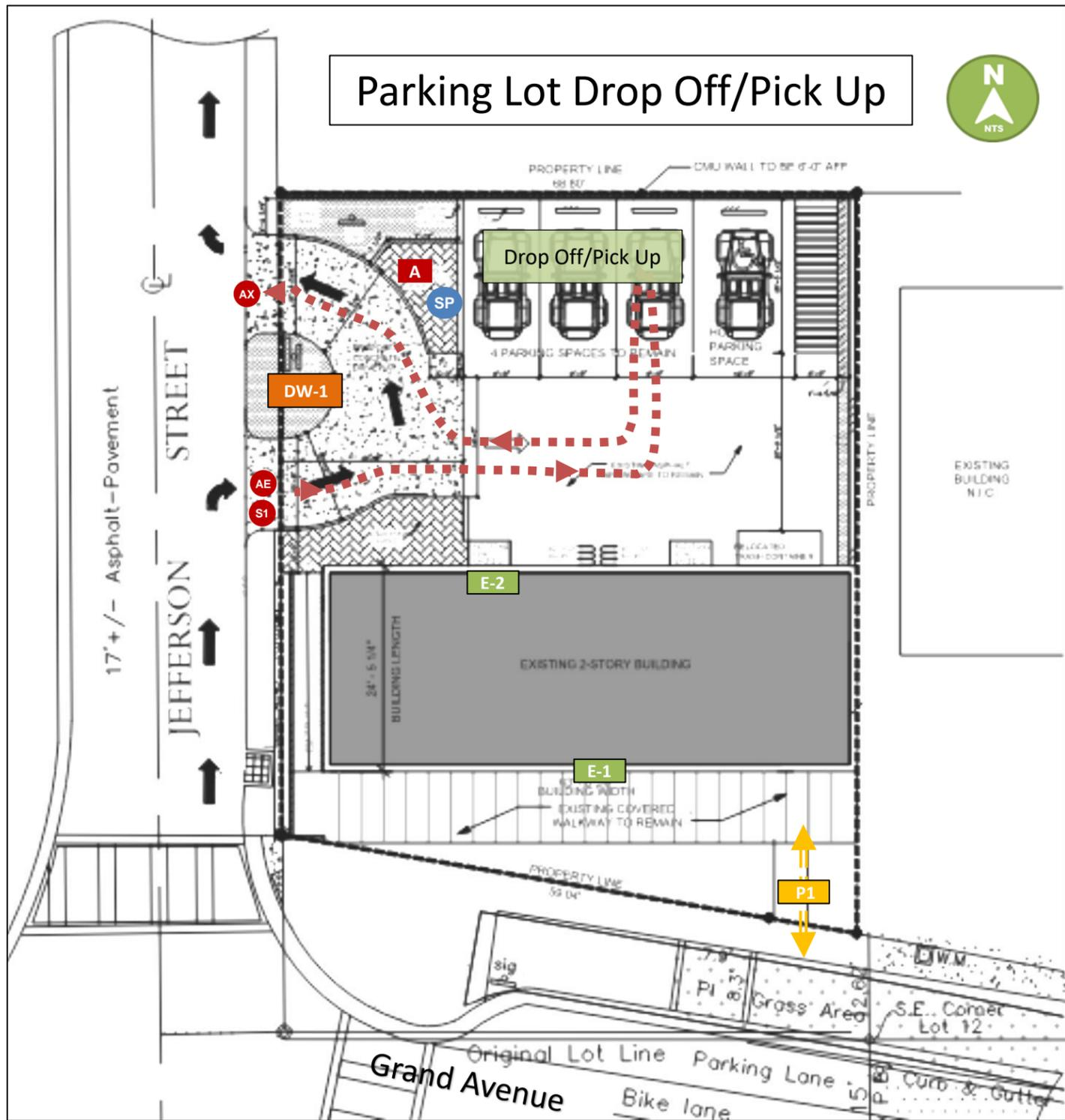

Legend

A-Automobile Loading Route	Automobile Entrance Point
P-Pedestrian Route	Automobile Exit Point
Auto Loading Zone	Service Access Point
Driveway	Pedestrian Access Point
Building Entrance Point	School Personnel

- NOTES:**
- 1.- The School site will only be used for drop-off and pick-up operations.
 - 2.- Parents who use Offsite Parking B shall walk their children between this area and the school at all times.
 - 3.- The school will not allow any students to walk or ride a bicycle to and from school. This will be enforced by the school.
 - 4.- Parents will be assigned a drop-off/pick-up location and designated/scheduled time.
 - 5.- School personnel will perform traffic control for entering and exiting vehicle on site at loading area and within parking lot when necessary.

SIGNATURE _____ DATE SIGNED _____ JOHN P. KIM PROFESSIONAL ENGINEER FL Lic. No. 62400			Project Sparks Learning, Inc. Microschool 141 Grand Avenue Coral Gables MIAMI-DADE COUNTY FLORIDA	Drawing Title TRAFFIC OPERATIONS PLAN Onsite Loading	Project No. 2023030081 Date September 7, 2023 Scale Not to Scale Drawn By JPK Checked By JGK Submittal Date	Drawing No. TOP - 1.0
Date Description No. REVISIONS						

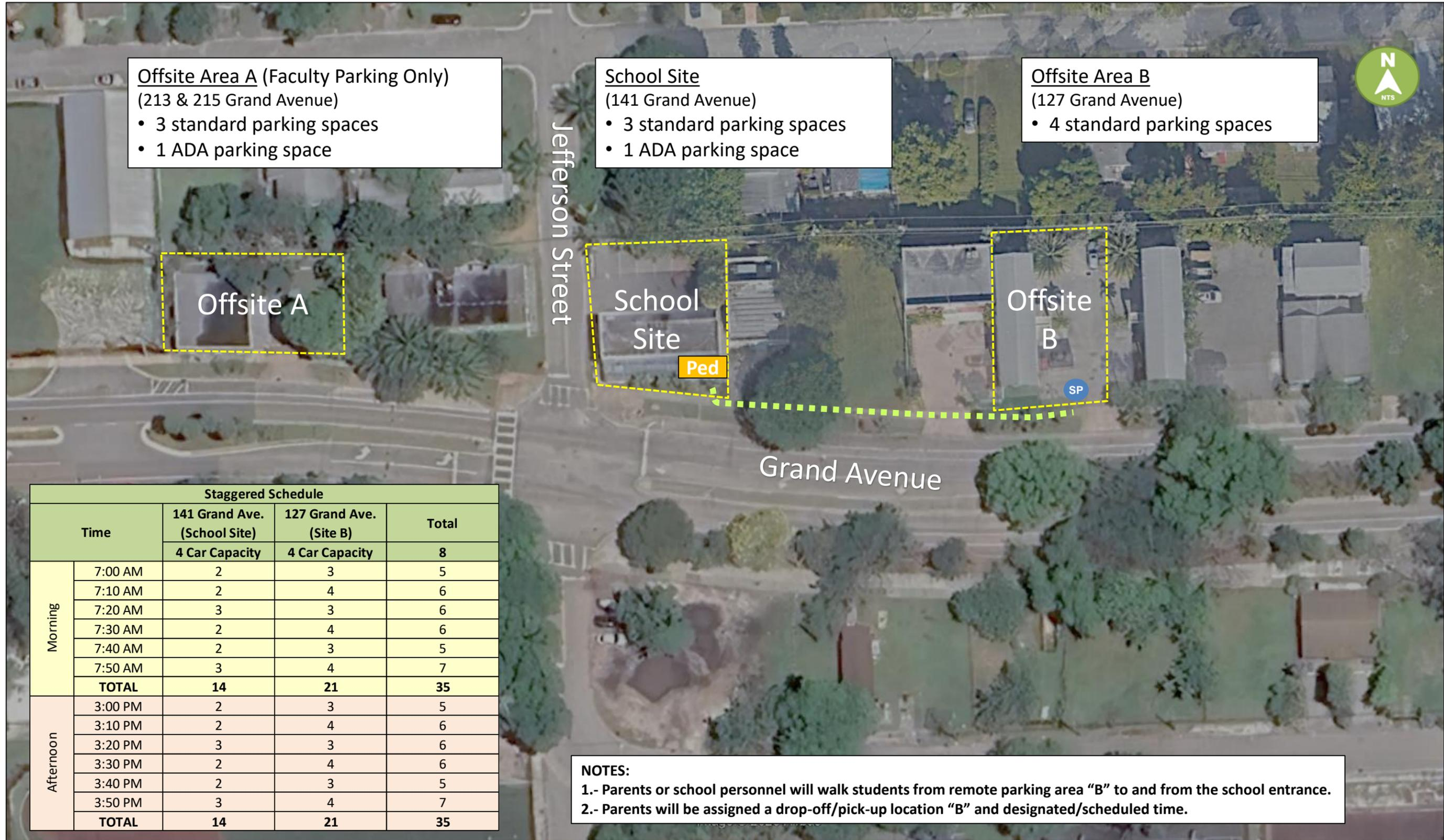

Offsite Area A (Faculty Parking Only)
 (213 & 215 Grand Avenue)
 • 3 standard parking spaces
 • 1 ADA parking space

School Site
 (141 Grand Avenue)
 • 3 standard parking spaces
 • 1 ADA parking space

Offsite Area B
 (127 Grand Avenue)
 • 4 standard parking spaces



Staggered Schedule				
Time		141 Grand Ave.	127 Grand Ave.	Total
		(School Site)	(Site B)	
		4 Car Capacity	4 Car Capacity	8
Morning	7:00 AM	2	3	5
	7:10 AM	2	4	6
	7:20 AM	3	3	6
	7:30 AM	2	4	6
	7:40 AM	2	3	5
	7:50 AM	3	4	7
	TOTAL		14	21
Afternoon	3:00 PM	2	3	5
	3:10 PM	2	4	6
	3:20 PM	3	3	6
	3:30 PM	2	4	6
	3:40 PM	2	3	5
	3:50 PM	3	4	7
	TOTAL		14	21

NOTES:
 1.- Parents or school personnel will walk students from remote parking area "B" to and from the school entrance.
 2.- Parents will be assigned a drop-off/pick-up location "B" and designated/scheduled time.

Legend

- P-Pedestrian Route
- Ped Pedestrian Access Point
- SP School Personnel

Date	Description	No.
REVISIONS		

SIGNATURE _____ DATE SIGNED _____
 JOHN P. KIM
 PROFESSIONAL ENGINEER FL Lic. No. 62400



Project
Sparks Learning, Inc.
Microschool
 141 Grand Avenue
 Coral Gables
 MIAMI-DADE COUNTY FLORIDA

Drawing Title
TRAFFIC OPERATIONS PLAN
Offsite Loading

Project No.
2023030081
 Date
September 7, 2023
 Scale
Not to Scale
 Drawn By
JPK
 Checked By
JGK
 Submittal Date

Drawing No.
TOP - 2.0

ATTACHMENT D
County TOP Form

School Traffic Operation Plan (TOP) Form

This form has been created by Miami-Dade County Department of Transportation and Public Works (DTPW) to document a school's traffic operations and commitments. All form worksheets and illustrations have been completed for the operation at

Contents

1.0	Definitions	5.6	Service Vehicle Operations
2.0	School Location	6.0	Pedestrian and Bicycle Facilities
3.0	Educational Program and Enrollment	7.0	Onsite Traffic Personnel and Devices
4.0	School Schedule	8.0	School Crossing and Speed Zone
4.1	School Schedule Commitment	9.0	Offsite Traffic Control Officers
4.2	School Schedule Example	9.1	State Crossing Guards
5.0	Vehicle Operations	10.0	Special Event Provisions
5.1	Vehicle Routes	11.0	Parent Traffic Handbook
5.2	Vehicle Stacking and Staging Spaces	12.0	Table Worksheets
5.3	Automobile Curbside Passenger Loading Zone	13.0	Attachments
5.4	School Bus Passenger Loading Zone	14.0	Endorsement
5.4a	School Bus Commitment		
5.5	Parking Stall Operations		

1.0 Definitions

For the purpose of this document, the following definitions for terms used herein shall apply to all sections unless the context clearly indicates otherwise:

- (1) *Educational program*: A planned curriculum with specific instructional beginning, progression and ending for the enrolled students.
- (2) *Schedule Shift*: A period of time when students are anticipated to be at the school facility to engage in programmed activities
 - (2.1) *Instructional Shift*: A period of time when students enrolled in a particular educational program must be in attendance. The beginning of this shift is often referred to as the "first bell" and the ending of this shift is often referred to as a "last bell."
 - (2.2) *Early Arrival Shift*: A period of time when students are allowed into the facility prior to the start of an instructional shift. This period may include other types of programs (e.g. breakfast, before care, etc.).
 - (2.3) *After School Shift*: A period of time when students are allowed to remain at the facility after the end of all instructional shifts. This period may include other types of programs (e.g. after care, extra-curricular, sports, etc.)
 - (2.4) *Study Hall*: A scheduled period of time, which begins with the school's first instructional shift (arrival time) and ends at the school's last instructional shift (dismissal time), where car-pooling students that arrive prior to their instructional shift and/or are dismissed earlier than their pick-up time (due to co-passenger students) are provided free of charge care.
 - (2.5) *Arrival Period*: A time or period of time when students come to school to participate in an educational program. The time or period of time is set by the beginning of one or more instructional shifts.

School Traffic Operations Plan (TOP) Form

- (2.6) *Dismissal Period:* A time or period of time when students leave school due to the end of an educational program. The time or period of time is set by the end of one or more instructional shifts.
- (3) *Vehicle Route:* A maneuverable continuous vehicle path that provides access to the stacking and staging spaces.
- (4) *Vehicle Stacking Space:* A space in which pickup and delivery of children can take place.
- (5) *Vehicle Queuing Space:* A space where a vehicle can idle while waiting to enter into a stacking space.
- (6) *Vehicle Staging Space:* A space where a service vehicle may remain idle while providing their service.
- (7) *Parked Stacking Space:* A parking space designated for student drop-off and pick-up use during the arrival and dismissal operations.
- (8) *By-Pass Lane:* A minimum 10 foot wide vehicle travel lane adjacent to stacking and queuing spaces whose direction of travel is in the same direction as the stacking and queuing vehicles.
- (9) *Open Parking Space:* A parking space that has no assigned use during the arrival and dismissal operations.
- (10) *Staff Parking Space:* A parking space designated for staff use during the school's hours of operation.
- (12) *Student Parking:* A parking space designated for student use during the school's hours of operation.
- (13) *Pedestrian Route:* A continuous exclusive walking path that provides access from the public right-of-way to a school building entrance.
- (14) *Bicycle Route:* A continuous biking path that provides access from the public right-of-way to the school's bicycle storage.
- (15) *Bicycle Storage:* A designated area where bicycles may be secured and remain in place for the school day.
- (16) *School Traffic Personnel:* A school employee who reinforces the onsite traffic operations by guiding vehicles and pedestrians along designated routes within the school property.
- (17) *Traffic Control Officer:* An individual who has been authorized by a police department to direct traffic or operate a traffic control device as per section 316.640 of Florida Statute.
- (18) *School Special Event:* An organized event at a school facility that generates a peak vehicle trip count or a vehicle accumulation demand greater than the traffic parameters established by the school traffic operation plan.
- (19) *School Crossing:* An official school student crossing on an adopted school route plan of a school safety program. Any crossing not so officially designated is termed a "pedestrian crossing."

2.0 School Location

Specify the school's name, site address, folio and hours of operation within the **Table 2.0-1**.

3.0 Educational Program and Enrollment

A school provides instructions to students through its *educational programs* (Elementary, Middle, High, ect). Specify the school's educational programs and maximum enrollment by completing **Table 3.0-1**. Indicate the school's programs by entering the student enrollment associated with each program and/or enter "None" for student enrollment if a particular program does not operate at the school.

School may offer educational programs that vary substantially from programs typically offered in schools. Provide a description of the school's educational programs in **Table 3.0-2**.

4.0 School Schedule

A school schedule is composed of *schedule shifts*. A schedule shift may be classified as either a non-instructional shift (Breakfast Program, After School Care, or Extra Curricular Activity) or an *instructional shift*. The educational programs are scheduled by *instructional shifts*. Therefore, every schedule will include at least one instructional shift. A school's *arrival period*, as well as *dismissal period*, should not exceed 1.5 hours because of its effect on school speed zone hours. The different educational programs may be scheduled independently or concurrently, but an educational program may not be divided by multiple instructional shifts. Instructional shifts must be scheduled a minimum of 20 minutes apart to have their vehicle accumulation events be considered as independent events. The schedule may also include an *early arrival shift* and an *after school shift*. A school that proposes to operate with multiple instructional shifts must enact the multiple shifts from inauguration, regardless of student enrollment. For example, a K-8 school, which has two educational programs (K-5 and 6-8), may operate with one or two instructional shifts, but may not operate with three instructional shifts.

A school's schedule may often be influenced by the site's vehicle accumulation capacity and other off-site traffic operational factors. A site's vehicle accumulation capacity and other factors are typically defined within a traffic study conducted by the school.

Schools that operate with multiple instructional shifts are required to operate a "*study hall*" period. The study hall period begins with the school's first arrival time and ends at the school's last dismissal time. This period must be provided free of charge for car-pooling students that arrive prior to their instructional shift and/or are dismissed earlier than their pick-up time due to co-passenger students.

4.1 School Schedule Commitment

The school schedule will maintain the maximum number of students allowed per instructional shift and operate with the number of instructional shifts stated in **Table 4.1-1**, with a minimum 20 minute separation between any two instructional shifts. Parental vehicular access to onsite passenger loading facilities shall be open a minimum of 30 minutes prior to all arrival and dismissal time(s).

The school will operate a "study hall" period when its schedule has more than one instructional shift.

4.2 School Schedule Example

The school is required to maintain the schedule commitment at all times. This commitment will define the school staggered shift schedule format, but actual start and end times may differ. Provide an example of the school schedule at full capacity in **Table 4.2-1**.

School may offer educational programs that vary substantially from programs typically offered in schools. Provide a description of the school’s schedule shifts in **Table 4.22**.

5.0 Vehicle Operations

A school has various vehicle types that access the site regularly. These vehicle types may include automobiles, school buses, and service vehicles such as food delivery trucks and trash collecting trucks. The various vehicles require clear traffic patterns to maintain the site’s safety and maneuverability when accessing the site. These patterns are termed *vehicle routes*. Once vehicles are on site, they accumulate as parking, *stacking*, *queuing*, or *staging*. The following section will formally define these vehicle routes and spaces within the TOP.

5.1 Vehicle Routes

Vehicle routes consist of an entry, a pathway, and an exit. All routes must provide the appropriate geometry (e.g. lane width, effective radii) to accommodate the intended vehicles. The route should minimize the number of conflict throughout its pathway. Each portion of the route must be identified using the following formats stated below.

Vehicle Route Naming Format: Each route must be assigned a name that indicates its intended “purpose” and “service”. Use the abbreviations contained in **Table 5.1-1** to appropriately name the routes. For example, a curbside automobile passenger loading zone that is to be used by parents dropping-off elementary school students would be named “A(K-5)”.

Table 5.1-1 Route Name Key

“Purpose”		“Service”	
A	Automobile Loading Zone	K-12	Student Passengers –specify grade range
B	Bus Loading Zone	Food	Food Delivery
P	Parking	Trash	Garbage Pick-up
S	Service Vehicle	Delivery	General Delivery
PED	Pedestrian Pathway		
BIK	Bicycle Pathway		

Route Entry and Exit Label Format: Each route’s entry and exit location must be assigned a label. Each location label will be composed of an abbreviated location type and a number. Use **Table 5.1-2** to provide the correct abbreviated location type and number. **Route names, entries, and exits must be illustrated in a plan view and attached to this document.**

Table 5.1-2 Route Entry and Exit Location - Labeling Key

Location Type		Number
DW	Driveway accessing the site	Number all the locations sequentially for each "location type" set. Start with the number 1. Begin numbering from the NE corner of the plan and increase the numbers sequentially in a clock-wise direction until all locations are labeled.
P	Point located within a plan	
E	Pedestrian and Bicycle Entrance and/or Exit	

Example: The entry and exit locations for a site that has two driveways (DW-1, DW-2) connecting to the public right-of-way, an internal drive aisle (P-1) connecting to the adjacent property, and a sidewalk connecting the main entrance (E-1) to the public right-of-way (E-2); will have three vehicle locations labeled as DW-1, DW-2, and P-1 and two pedestrian locations labeled E1 and E2.

Entry and exit points along the vehicle route may have operational restrictions. The restrictions may be in place permanently or only during the times when the TOP is in effect. Use **Table 5.1-3** to better understand the restriction notes to be used throughout this form.

Table 5.1-3 Route Restrictions Note Key

Restriction Note	Description
Right In Only	Vehicles may only enter into this location via a right turn movement.
One Way Only	All traffic is moving solely in one direction at this location.
Right Out Only	Vehicles may only exit out of this location via a right turn movement.

5.2 Vehicle Stacking and Staging Spaces

All stacking and staging spaces must be accessed through a vehicle route. The stacking, queuing, and staging spaces along a vehicle route may not impede the operations of any other concurrently operating vehicle route or space operation. For example, a stacked or queued vehicle may not be located within the maneuvering "back-out" area of a parking space designated as a *parked stacking space*.

Vehicle stacking spaces within passenger loading zones must have a passenger landing area for entering and exiting the vehicle. A 10 foot minimum *by-pass lane* must be provided for passenger loading zones whose combined stacking and queuing spaces are longer than 3 consecutive vehicle spaces. Parking spaces may be designated as stacking spaces. Access to the vehicle stacking spaces must be opened 30 minutes before the first scheduled time of use.

5.3 Automobile Curbside Passenger Loading Zone Operations

An automobile passenger loading zone is a designated area for stacking automobiles and vans to load and unload passengers to and from a prescribed landing area. The pedestrian landing area for automobile loading zones must be located on the right side of the vehicle and should have a minimum size of 5 feet by 5 feet. Typically these landing areas are considered curbside passenger loading areas because the vehicles stack adjacent to a curbed sidewalk. Automobile passenger loading zones that have a by-pass lane should taper the head of the zone (the front space of the stacking line) towards the by-pass lane to merge the exiting stacked vehicles into the by-pass lane.

School Traffic Operations Plan (TOP) Form

Specify if the school operates one or more automobile passenger loading zones by providing information of the vehicle route that provides access to the zone within the **Table 5.3-1**, or indicate no zone by entering “None” for the route name. **The vehicle route must be illustrated in a plan view and attached to this document.**

The use of automobile passenger loading zones are limited to automobiles and vans only. Each vehicle space is measured at 22 feet long and 8 feet wide. If the school operates with an automobile passenger loading zone, indicate its capacity in **Table 5.3-2**. Enter zero (0) for the total capacity if the school does not have an automobile passenger loading zone.

5.4 School Bus Passenger Loading Zone Operations

A school bus passenger loading zone is a designated zone for stacking school buses to load and unload passengers to and from a prescribed landing area. The pedestrian landing area for school bus passenger loading zones must be located on the right side of the vehicle and should have a minimum size of 8 feet by 8 feet.

Specify if the school operates one or more school bus passenger loading zones by providing information of the vehicle route that provides access to the zone within the **Table 5.4-1**, or indicate no zone by entering “None” for the route name. **The vehicle route must be illustrated in a plan view and attached to this document.**

The use of school bus passenger loading zones are limited to only school buses during arrival and dismissal operations. Each bus vehicle space measures 50 feet long and 10 feet wide unless otherwise stated in **Table 5.4a-2**. If the school operates with a school bus passenger loading zone, indicate its capacity in **Table 5.4-2**. Enter zero (0) for the total capacity if the school does not have a school bus passenger loading zone.

The school’s bus operations may be voluntary, recommended in a traffic study, and/or mandated by zoning resolution. Complete the section 5.4a to specify the minimum number of school buses required to operate at the school.

5.4a School Bus Commitment

Specify the school’s busing commitment by completing **Table 5.4a-1** and **Table 5.4a-2**. Report zero (0) number of buses if the school has no busing commitment. Standard bus types have been provided in **Table 5.4a-2** for convenience.

The school is required to provide a school bus program that maintains the required minimum bus ridership participation reported in **Table 5.4a-1** and **Table 5.4a-2**; and manage the program to ensure that bus accumulations are contained within the designated bus stacking and queuing spaces.

5.5 Parking Stall Operations

All parking spaces used during the school’s operation must be identified. The parking spaces must meet all governing parking stall codes.

Parked stacking spaces must have an unobstructed vehicle route to access these spaces during arrival and dismissal shifts. Parking spaces that have no assigned use during arrival and dismissal operations due to vehicle route obstructions will be termed *open parking spaces*. A cross parking agreement is required for all off-site privately managed parking spaces.

School Traffic Operations Plan (TOP) Form

Specify the school's parking space usage and quantities by completing **Table 5.5-1**. **The parking spaces must be illustrated in a plan view and attached to this document.**

If the school has parked stacking spaces or *student parking spaces*, specify the route information that provides access to those spaces within the **Table 5.5-2**, or indicate no routes by entering "None" for the route name. **The vehicle route must be illustrated in a plan view and attached to this document.**

5.6 Service Vehicle Operations

Schools often require service vehicles to enter and maneuver within the site to provide facility services. Specify the school's service vehicle routes by providing the vehicle route information within the **Table 5.6-1**, or indicate no routes by entering "None" for the route name. **The vehicle route must be illustrated in a plan view and attached to this document.**

6.0 Pedestrian and Bicycle Facilities

A *pedestrian route* originating from the public right-of-way must be provided to all school building entrances. The route should be a minimum of 5 feet wide and have all the required elements when crossing a motorized vehicle travel lane (crosswalk, pedestrian ramp, etc.). All student entrances to the school site and buildings must be labeled by using **Table 5.1-2**. Only the main entrance is required to be labeled when multiple buildings are interconnected with pedestrian pathways.

Bicycle routes that are combined with pedestrian traffic must have an eight (8) foot minimum width.

For sites that have a bicycle storage area and that only provide standard pedestrian path widths are required to institute the following policy: "*All bicyclists must dismount their bicycles and walk their bicycles to the designated bicycle storage when entering or exiting to the school site.*"

Specify the pedestrian routes by providing the route information within the **Table 6.0-1**. **The pedestrian route must be illustrated in a plan view and attached to this document.**

Specify the bicycle routes by providing the route information within the **Table 6.0-2**, or indicate no routes by entering "None" for the route name. **The bicycle route must be illustrated in a plan view and attached to this document.**

Identify the *bicycle storage* locations throughout the site by labeling each location according to the following instructions: Each location must be label with the letters BS followed by a number (e.g. BS1). Begin with number 1. Do not repeat any location labels. List the storage locations and its capacity in **Table 6.0-3**. Enter "none" for the location to indicate no bicycle storage. **The bicycle storage location must be illustrated in a plan view and attached to this document.**

7.0 Onsite Traffic Personnel & Devices

A functioning school TOP requires adherence to the prescribed routes and operations. Often *school traffic personnel* is required to guide pedestrians within passenger loading zones, assist with traffic flow at route conflict points, and encourage adherence to prescribed routes in areas not defined by the infrastructure's geometry. The school shall supply staff to direct any vehicles which may stage or stack in through travel lanes or non-designated parking areas within the public rights-of-way onto the school site.

School Traffic Operations Plan (TOP) Form

School traffic personnel should be stationed and assigned the following duties at the corresponding locations: assist students entering and exiting vehicles at loading zones (loading); guide traffic at points where active route pathways intersect (conflict); and encourage adherence at pathway decision points along the route (diverting). School traffic personnel should be on duty at least 30 minutes prior to scheduled shifts.

Identify the school traffic personnel stations throughout the site by labeling each station according to the following instructions: Each station must be labeled with the letter S followed by a number (e.g. S1). Begin with number 1. Do not repeat any station labels. List the station locations and personnel duties in **Table 7.0-1**. Enter “none” for the location to indicate no school traffic personnel stations. **The school traffic personnel stations must be illustrated in a plan view and attached to this document.**

Temporary traffic control devices (e.g. parking cones) may be useful at points within the routes that are not defined by the infrastructure’s geometry and where school traffic personnel are not stationed. These temporary traffic devices may not be used in the public right-of-way unless managed by a traffic control officer.

Identify the temporary traffic control devices located throughout the site by labeling each location according to the following instructions: Each location must be labeled with the letter C followed by a number (e.g. C1). Begin with number 1. Do not repeat any station labels. List the device location and description in **Table 7.0-2**. Enter “none” for the location to indicate that no devices will be used. **The device locations must be illustrated in a plan view and attached to this document.**

7.1 School Personnel Commitment

The school is required to provide the school traffic personnel and temporary traffic control devices stated in **Table 7.0-1** and **Table 7.0-2**. School traffic personnel must direct the school’s traffic into onsite by-pass lanes or any available vehicle staging spaces during peak traffic generation periods to create additional onsite accumulation capacity when school related vehicles are queuing within non-designated areas of the right-of-way and/or through travel lanes.

8.0 School Zone and Crossings

School zones may be provided for schools to alert drivers that they will be traveling near a school. A school zone is composed of signs and pavement markings. The school zone may also include a speed zone component that requires driver to reduce their travel speed. The speed zone is often enacted to provide control at designated *school crossings* serving elementary and middle schools. The school speed zone component may be composed of signs, pavement markings, and flashing beacons (as per the governing standard). The speed zone is required to be installed for school crossings when applicable.

Indicate the existing and/or proposed school crossing(s) serving the school site within **Table 8.0-1**. Enter “none” for the road name to indicate that no school crossing exists or is proposed for this school. **The school crossing locations must be illustrated in a plan view and attached to this document.**

School Traffic Operations Plan (TOP) Form

Indicate the existing and/or proposed school zones associated with the school site within **Table 8.0-2**. Enter “none” for the road name to indicate that no school zone exists or is proposed for this school. Indicate if a speed zone is a component of the school zone by marking the appropriate check box.

A school speed zone should not have a continuous duration longer than two hours. If this school is served by a school speed zone, then specify the zone’s posted hours in **Table 8.0-3**. Enter “none” for the period to indicate no posted hours. Use DTPW School Speed Zone Policy to determine appropriate time periods. Note that if the school is located in close proximity to an existing school speed zone (less than 300 feet), the zone and time period may be modified to cover both schools. Indicate below if the times are paired. If paired, provide areal illustrating adjacent school(s).

9.0 Offsite Traffic Control Officers

Enforcement of the TOP routes and operations within the public right-of-way may only be performed by *traffic control officers* as per section 316.640 of the Florida Statute. Traffic control officers should be present during the start of each semester (first two weeks) to reinforce the traffic patterns established by the TOP. Specify the number, location, and duration of traffic control officers required to adequately enforce the TOP within **Table 9.0-1**.

The school’s endorsement of the traffic control officer enforcement plan must be stated within **Table 9.0-2**.

A traffic control officer may be stationed at an intersection to improve vehicle delays and operations during a peak traffic demand period. Schools may be required to provide the officer, or may do so voluntarily. Specify the commitment, location, and duration of the traffic control officer stations required for LOS management within **Table 9.0-3**. Enter “none” for the intersection to indicate that no officer management is voluntarily offered or required.

9.1 State Crossing Guards

A school may implement a crossing guard program to assist young (K-8) students traversing school crossings when walking to and from school. A crossing guard is not traffic control officer, unless the guard is trained as a traffic control officer and employed subject to the conditions described in section 316.640, F.S. Specify the crossing guard stations and duration within **Table 9.1-1**. Enter “none” for the station to indicate that no crossing guards are stationed to serve the school.

10.0 School Special Events

Planned school events, such as sporting events, school assemblies, and ceremonies may often generate larger peak traffic volumes and vehicle accumulations than a typical school day. The school will be required to manage the traffic impacts produced by a *school special event* within its neighborhood. Specify the special event types and provisions selected to mitigate its traffic impacts within **Table 10.0-1**. Enter “none” for event type to indicate that no school special events will planned at the school site.

11.0 Parent Traffic Handbook

The Parent Traffic Handbook specifies a parent’s child safety responsibilities and commitment to achieve an efficient traffic flow during the arrival and dismissal times. Parents of new students should be issued a Parent Traffic Handbook containing this TOP and are required to sign a contract with the school, which includes adherence to pick-up and drop-off procedures. Additionally, parents should be reissued the Parent Traffic Handbook and contract each new school year. The handbook and contract should be reviewed and signed during Parent Orientation prior to the start of school. **A sample of the Parent Traffic Handbook and contract must be attached to this document.**

12.0 Table Worksheets

Complete this worksheet as per the instructions provided in sections 1.0 through 11.0 of this document.

Educational Program Worksheet

Table 2.0-1 School Location

Name	
Address	
Folio Number(s)	
Hours of Operations	

Table 3.0-1 Educational Program and Enrollment

Educational Program	Grades	Average Maximum Enrollment per Grade	Maximum Enrollment
Total Facility Enrollment			

Table 3.0-2 Educational Program Descriptions

Educational Program	Description

School Schedule Worksheet

Table 4.1-1 School Schedule Commitment

Period	Maximum Number of Students Allowed within a Schedule Shift	Minimum Number of Instructional Shifts at Full Enrollment
Arrival		
Dismissal		

Table 4.2-1 School Schedule Example at Full Capacity

Schedule Shift	Grades	Days [M, Tu, W, Th, F]	Begin Time	End Time	No. of Students

Automobile Passenger Curbside Loading Zone Worksheet

Table 5.3-1 Automobile Loading Zone Route Description

Route Name	Entrance Point	[X]	Restriction	Exit Point	[X]	Restriction	Description
		<input type="checkbox"/>	Right In Only		<input type="checkbox"/>	Right Out Only	
		<input type="checkbox"/>	One Way Only		<input type="checkbox"/>	One Way Only	
		<input type="checkbox"/>	Right In Only		<input type="checkbox"/>	Right Out Only	
		<input type="checkbox"/>	One Way Only		<input type="checkbox"/>	One Way Only	
		<input type="checkbox"/>	Right In Only		<input type="checkbox"/>	Right Out Only	
		<input type="checkbox"/>	One Way Only		<input type="checkbox"/>	One Way Only	
		<input type="checkbox"/>	Right In Only		<input type="checkbox"/>	Right Out Only	
		<input type="checkbox"/>	One Way Only		<input type="checkbox"/>	One Way Only	

Table 5.3-2 Automobile Loading Zone Vehicle Capacity Summary (Automobiles and Vans)

Route Name	Stacking Space Capacity	Queuing Spaces Capacity	Total Capacity

Bus Passenger Loading Zone Worksheet

Table 5.4-1 School Bus Passenger Loading Zone Route Description

Route Name	Entrance Point	[X]	Restriction	Exit Point	[X]	Restriction
		<input type="checkbox"/>	Right In Only		<input type="checkbox"/>	Right Out Only
		<input type="checkbox"/>	One Way In		<input type="checkbox"/>	One Way Out
		<input type="checkbox"/>	Right In Only		<input type="checkbox"/>	Right Out Only
		<input type="checkbox"/>	One Way In		<input type="checkbox"/>	One Way Out
		<input type="checkbox"/>	Right In Only		<input type="checkbox"/>	Right Out Only
		<input type="checkbox"/>	One Way In		<input type="checkbox"/>	One Way Out

Table 5.4-2 Bus Loading Zone Vehicle Accumulation Capacity Summary

Route Name	Stacking Spaces Capacity	Queuing Spaces Capacity	Bus Capacity

Table 5.4a-1 Bussing Commitment

Minimum Number of Inbound Buses Required During the Arrival Period	Minimum Number of Outbound Buses Required During the Dismissal Period

Table 5.4a-2 Bus Type and Capacity

Quantity	Bus Type	Length	Width	Capacity	Student Total by Type
	S-BUS-11 [S-BUS-36]	45	10	65	
	S-BUS-12 [S-BUS-40]	50	10	84	
Students Grand Total					

Parking Summary Worksheet

Table 5.5-1 Proposed Parking Use Summary

Parking Space Use	Onsite			Offsite
	Req. by Code	Req. by Study	Provided	Provided
Staff				
Student				
Parked Stacking *				
Open				
Total				

*Includes 1 drop off space and temporary use of ADA space

Table 5.5-2 Parked Loading Zone Route Description

Route Name	Entrance Point	[X]	Restriction	Exit Point	[X]	Restriction
		<input type="checkbox"/>	Right In Only		<input type="checkbox"/>	Right Out Only
		<input type="checkbox"/>	One Way In		<input type="checkbox"/>	One Way Out
		<input type="checkbox"/>	Right In Only		<input type="checkbox"/>	Right Out Only
		<input type="checkbox"/>	One Way In		<input type="checkbox"/>	One Way Out
		<input type="checkbox"/>	Right In Only		<input type="checkbox"/>	Right Out Only
		<input type="checkbox"/>	One Way In		<input type="checkbox"/>	One Way Out

Service Vehicle, Pedestrian and Bicycle Routes Worksheet

Table 5.6-1 Service Vehicle Route Description*

Route Name	Entrance Point	[X]	Restriction	Exit Point	[X]	Restriction	Operation Period (times)
		<input type="checkbox"/>	Right In Only		<input type="checkbox"/>	Right Out Only	
		<input type="checkbox"/>	One Way In		<input type="checkbox"/>	One Way Out	
		<input type="checkbox"/>	Right In Only		<input type="checkbox"/>	Right Out Only	
		<input type="checkbox"/>	One Way In		<input type="checkbox"/>	One Way Out	
		<input type="checkbox"/>	Right In Only		<input type="checkbox"/>	Right Out Only	
		<input type="checkbox"/>	One Way In		<input type="checkbox"/>	One Way Out	

Table 6.0-1 Pedestrian Route Description*

Route Name	Off-Site Entrance Point	Building Entrance Point	Operation Period (0:00-0:00)

The P1 Pedestrian Entrance is only for pedestrians traveling to/from Offsite Loading Area B

Table 6.0-2 Bicycle Route Description*

Route Name	Entrance Point	Exit Point	Operation Period (0:00 – 0:00)

Table 6.0-3 Bicycle Storage Description*

Bicycle Storage Location	Bicycle Capacity

* The school will not allow any students to walk or ride a bicycle to and from school.

Traffic Personnel, Equipment, Enforcement Worksheet

Table 7.0-1 Onsite School Traffic Personnel

Station Label	Personnel Duties (Loading, Conflict, Diverting)	Arrival Duty Period		Dismissal Duty Period	
		From	To	From	To

Table 7.0-2 Onsite Temporary Traffic Control Devices

Location Label	Device Description (Number of Cones, Barricades, or Gates)	Arrival Duty Period		Dismissal Duty Period	
		From	To	From	To

Table 8.0-1 School Crossing Description

Location	East-West	North-South	Mid-Block	Uncontrolled
	<input type="checkbox"/>	<input type="checkbox"/>	<input type="checkbox"/>	<input type="checkbox"/>
	<input type="checkbox"/>	<input type="checkbox"/>	<input type="checkbox"/>	<input type="checkbox"/>
	<input type="checkbox"/>	<input type="checkbox"/>	<input type="checkbox"/>	<input type="checkbox"/>
	<input type="checkbox"/>	<input type="checkbox"/>	<input type="checkbox"/>	<input type="checkbox"/>
	<input type="checkbox"/>	<input type="checkbox"/>	<input type="checkbox"/>	<input type="checkbox"/>
	<input type="checkbox"/>	<input type="checkbox"/>	<input type="checkbox"/>	<input type="checkbox"/>

School Traffic Operations Plan (TOP) Form

Table 8.0-2 School Zone Description

Location	Existing [x]	Proposed [x]	Signs & Markings [x]	Speed Zone [x]	Flashing Beacons [x]
	<input type="checkbox"/>	<input type="checkbox"/>	<input type="checkbox"/>	<input type="checkbox"/>	<input type="checkbox"/>
	<input type="checkbox"/>	<input type="checkbox"/>	<input type="checkbox"/>	<input type="checkbox"/>	<input type="checkbox"/>
	<input type="checkbox"/>	<input type="checkbox"/>	<input type="checkbox"/>	<input type="checkbox"/>	<input type="checkbox"/>
	<input type="checkbox"/>	<input type="checkbox"/>	<input type="checkbox"/>	<input type="checkbox"/>	<input type="checkbox"/>

Table 8.0-3 School Speed Zone Posted Times Is this a paired Zone? No Yes

Days of the Week	Arrival Period AM		Dismissal Period PM	
	From	To	From	To
Monday				
Tuesday				
Wednesday				
Thursday				
Friday				

Table 9.0-1 Traffic Control Officer Enforcement Plan

No. of Officers	Intersection or Segment with Boundaries	Arrival	Dismissal	Semester Start	All Year
		<input type="checkbox"/>	<input type="checkbox"/>	<input type="checkbox"/>	<input type="checkbox"/>
		<input type="checkbox"/>	<input type="checkbox"/>	<input type="checkbox"/>	<input type="checkbox"/>
		<input type="checkbox"/>	<input type="checkbox"/>	<input type="checkbox"/>	<input type="checkbox"/>
		<input type="checkbox"/>	<input type="checkbox"/>	<input type="checkbox"/>	<input type="checkbox"/>

Table 9.0-2 Traffic Control Officer Reinforcement Commitment

Check Box [x]	Reinforcement Commitment
<input type="checkbox"/>	By marking this check box, the school agrees to provide all necessary resources to ensure traffic control officers will be present to enforce the TOP, as stated in Table 9.0-1 .

Table 9.0-3 Traffic Control Officer Stations for LOS Management Plan

Intersection	Required (R) Voluntarily (V)	Arrival Time Period		Dismissal Time Period	
		From	To	From	To

School Traffic Operations Plan (TOP) Form

Table 9.1-1 Crossing Guard Stations

No. of Guards	School Crossing Station (Intersection)	Arrival AM Time Period		Dismissal PM Time Period	
		From	To	From	To

Table 10.0-1 School Special Event Provisions

Event Type	Provision Descriptions

13.0 Attachments

The following documents are required to be attached to the TOP.

1. A plan sheet showing all required illustrations stated within this TOP form. (It is suggested that TOP operations that vary by instructional shifts be shown in independent plan sheets.)
2. A Parent Traffic Handbook and contract sample.
3. A Cross-parking agreement (if utilized).

14.0 Endorsement

By signing below, the school owner agrees to operate the school as prescribed within this document and will uphold all commitments specified herein.

Joseph Lindsay
Signature

08/30/2023
Date

Joseph Lindsay
Print Owner Name

Parking Agreement

THIS AGREEMENT (the "Agreement"), dated the 18 day of July, 2023, is made between **Baruch Properties, LLC**, a Florida limited liability company (the "Owner"), and **Spark Learning, Inc.**, a Delaware corporation (dba Primer Microschools, the "Renter").

Agreement Summary

The following is a summary of the basic provisions with respect to the agreement.

- 1. Date of Agreement Execution: July 18, 2023
- 2. "Owner": Carlos A. Jimenez
Baruch Properties, LLC
- 3. Landlord's Address for Notices: 127 Grand Ave, Coral Gables, FL 33133
Attention: Carlos A. Jimenez
- 4. "Renter": Spark Learning, Inc. dba Primer
Microschools
- 5. Renter's Address for Notices: 141 Grand Ave, Coral Gables, FL 33133
Attention: Stephan A. Koetzle
- 6. "Premises": 4 spaces in the parking lot located at
127 Grand Ave, Coral Gables, FL 33133
- 7. Permitted Use of Premises: Parking for the operation of a school
and ancillary and related uses, in
compliance with all applicable laws.
- 8. Term of Agreement: Five (5) years commencing on the Date
of Agreement Execution.
- 9. Termination: Either party may terminate this
agreement at any time with 90 days
written notice.
- 10. Cost: \$500 per month. First 12 months due
within 5 business days of Date of
Agreement Execution as prepayment.

IN WITNESS WHEREOF, Owner and Renter have executed this Agreement as of the date first above written.

OWNER:

Carlos A. Jimenez, *President*
Baruch Properties, LLC

By: *[Signature]*
Date: 7/25/23
Name: Carlos A Jimenez
Title: President/owner

RENTER:

Spark Learning, Inc DBA Primer
Microschools

DocuSigned by:
Garrett Spiegel
By: *[Signature]*
Date: 7/24/2023
Name: Garrett Spiegel
Title: Director of Operations

Parking Agreement

THIS AGREEMENT (the "Agreement"), dated the 18 day of July, 2023, is made between **ALGIMABE LLC, a Florida limited liability company** (the "Owner"), and **Spark Learning, Inc., a Delaware corporation (dba Primer Microschools, the "Renter")**.

Agreement Summary

The following is a summary of the basic provisions with respect to the agreement.

- 1. Date of Agreement Execution: July 18, 2023
- 2. "Owner": ALGIMABE, LLC.
- 3. Landlord's Address for Notices: 215 Grand Ave, Miami, FL 33133
Attention: Alex Koetzle
- 4. "Renter": Spark Learning, Inc. dba Primer Microschools
- 5. "Premises": 4 spaces in the parking lot and access to 2 street parking spaces located at 213 Grand Ave, Miami, FL 33136
- 6. Permitted Use of Premises: Parking for the operation of a school and ancillary and related uses, in compliance with all applicable laws.
- 7. Term of Agreement: Five (5) years commencing on the Date of Agreement Execution.
- 8. Termination: Either party may terminate this agreement at any time with 90 days written notice.
- 9. Cost: None.

IN WITNESS WHEREOF, Owner and Renter have executed this Agreement as of the date first above written.

OWNER:

RENTER:

ALGIMABE, LLC

Spark Learning, Inc DBA Primer Microschools

By: 

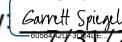
By: 

Date: 7/17/2023

Date: 7/31/2023

Name: ALEX KOETZLE

Name: Garrett Spiegel

Title: OWNER / MANAGING PARTNER

Title: Director of Operations

141 Grand Avenue – Conditional Use
Contact Information

Property Owner

141 Grand LLC, a Florida limited liability company
Ilan Kempner
ikempner@kempstar.com
305-330-4808
141 Grand Ave
Coral Gables, FL 33133

Applicant

Spark Learning, Inc.
Joseph Lindsay
joe@withprimer.com
786-877-6552
548 Market St, PMB 60414
San Francisco, CA 94104

Engineer

Calc Engineering
Masood Hajali, Ph.D., P.E.
masood@calceng.com
305-898-9995
2000 NW 89 Pl, Unit 102
Doral, FL 33172

Attorney

Berger Singerman LLP
Eddy Baker, Esq.
ebaker@bergersingerman.com
305-714-4379
1450 Brickell Ave, Ste 1900
Miami, FL 33133

SPARK LEARNING, INC.

04/07/2026

City of Coral Gables
Development Services
427 Biltmore Way
Coral Gables, Florida 33134

RE: Authorization of Principal

To whom it may concern:

Please let it be known that this is our written authorization from Spark Learning Inc., lobbyist Edward G. Baker is authorized to represent Spark Learning Inc. and obtain permits and plans for the property address located at 141 Grand Ave, Coral Gables, Florida, 33133.

DocuSigned by:
Joe Lindsay
C9DBD82476FD49E...

Joe Lindsay



LOBBYIST REGISTRATION CERTIFICATE
CITY OF CORAL GABLES
CITY CLERK'S OFFICE

405 Biltmore Way - Coral Gables, FL 33134
305-460-5210 cityclerk@coralgables.com

LOBBYIST NAME: EDWARD G. BAKER

LOBBYIST ADDRESS: 1450 Brickell Ave., Suite 1900, Miami, FL 33131

PRINCIPAL NAME: SPARK LEARNING INC DBA PRIMER MICROSCHOOLS

PRINCIPAL ADDRESS: 382 NE 191 ST#60414, MIAMI, FL 33179

PRINCIPAL ISSUE: Conditional Use Permit

REGISTERED DATE: 3/16/2023

EXPIRATION DATE: 12/31/2023

State of Florida, City of Coral Gables
I HEREBY CERTIFY, that the foregoing is an official copy
of a lobbyist record electronically filed in this office.

This 16th day of March AD 2023

Billy Y Urquia, City Clerk

OATH

I do solemnly swear that all facts contained on this Annual Lobbyist Registration form and principal are true and correct; and that I have read and am familiar with the Ordinance 2017-44 of the Code of City of Coral Gables.



Prepared by:

Suzanne A. Dockerty
Attorney at Law
SUZANNE A. DOCKERTY, P.A.
110 Merrick Way Suite 3-B
Coral Gables, FL 33134
305-443-9162
File Number: 247110-461

Return to:

Bruce A. Lamchick
Attorney at Law
LAMCHICK LAW GROUP P.A
6910 N. Kendall Dr.
Miami, FL 33156

[Space Above This Line For Recording Data]

Warranty Deed

This Warranty Deed made this 31 day of **August, 2020** between **RERIT 141 LLC, a Florida limited liability company** whose post office address is **1825 Ponce de Leon Blvd., Suite 274, Coral Gables, FL 33134**, grantor, and **141 Grand LLC, a Florida limited liability company** whose post office address is **141 Grand Avenue, Coral Gables, FL 33133**, grantee:

(Whenever used herein the terms "grantor" and "grantee" include all the parties to this instrument and the heirs, legal representatives, and assigns of individuals, and the successors and assigns of corporations, trusts and trustees)

Witnesseth, that said grantor, for and in consideration of the sum of TEN AND NO/100 DOLLARS (\$10.00) and other good and valuable considerations to said grantor in hand paid by said grantee, the receipt whereof is hereby acknowledged, has granted, bargained, and sold to the said grantee, and grantee's heirs and assigns forever, the following described land, situate, lying and being in **Miami-Dade County, Florida** to-wit:

Lot 12, in Block 1-A, Combined and Supplemental Map of MAC FARLANE HOMESTE PLAT and ST. ALBAN'S PARK, according to the Plat thereof, recorded in Plat Book 5, at Page 81, of the Public Records of Dade County, Florida; less the following described property: That portion of Lot 12, in Block 1A, of Combined and Supplemental Map of MAC FARLANE HOMESTEAD PLAT and ST. ALBAN'S PARK, according to the Plat thereof, recorded in Plat Book 5, at Page 81, of the Public Records of Dade County, Florida, which lies Southerly of the following described line: Commence at the Southwest corner of said Lot 12, thence run North 5 degrees 09 minutes 54 seconds West along the West line of said Lot 12 for a distance of 23.79 feet to the Point of Beginning of the herein described line; thence run South 85 degrees 28 minutes 10 seconds East for a distance of 59.04 feet to the point of curvature of a circular curve to the left; thence run Southeasterly along the arc of said circular curve to the left having a radius of 1095.92 feet, through a central angle of 0 degrees 33 minutes 31 seconds for an arc distance of 10.68 feet to a point of intersection with the East line of said Lot 12 and to the END of the herein described line, said point of intersection being 12.62 feet North of the Southeast corner of said Lot 12 as measured along the East line of said Lot 12 and 13, in Block 1-A, of COMBINED AND SUPPLEMENTAL MAP OF MAC FARLANE HOMESTEAD PLAT AND ST. ALBAN'S PARK, according to the Plat thereof, recorded in Plat Book 5, Page 81, of the public records of Miami-Dade County, Florida.

Parcel Identification Number: 03-4120-006-0950

Together with all the tenements, hereditaments and appurtenances thereto belonging or in anywise appertaining.

To Have and to Hold, the same in fee simple forever.

And the grantor hereby covenants with said grantee that the grantor is lawfully seized of said land in fee simple; that the grantor has good right and lawful authority to sell and convey said land; that the grantor hereby fully warrants the title to said land and will defend the same against the lawful claims of all persons whomsoever; and that said land is free of all encumbrances, except taxes accruing subsequent to **December 31, 2019**.

In Witness Whereof, grantor has hereunto set grantor's hand and seal the day and year first above written.

Signed, sealed and delivered in our presence:

Witness Name: Suzanne Dockerty

Witness Name: Ida Fernandez

Witness Name: Suzanne Dockerty

Witness Name: Ida Fernandez

RERIT 141 LLC, a Florida limited liability company

By: [Signature]
Stefan Linn, Manager

By: [Signature]
Kerry Kiernan, Manager

State of Florida
County of Miami-Dade

The foregoing instrument was acknowledged before me by means of physical presence or online notarization, this 28 day of August, 2020 by Stefan Linn, Manager and Kerry Kiernan, Manager of RERIT 141 LLC, a Florida limited liability company, on behalf of the corporation. They are personally known to me or have produced a driver's license as identification.

[Notary Seal]

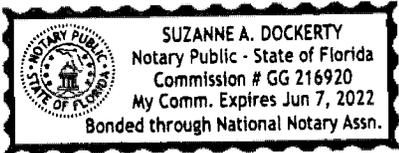

[Signature]
Notary Public

Printed Name: _____

My Commission Expires: _____



rdr miami | public hearing notification services

certified lists of property owners within a specific radius + radius maps + mailing labels + mailouts + notice of public hearing site posting
rdrmiami.com | diana@rdrmiami.com | 305.498.1614

August 7, 2023

City of Coral Gables
405 Biltmore Way
Coral Gables, Florida 33134

Re: Property owners within 1,000 feet of:

SUBJECT: 141 Grand Avenue, Coral Gables, FL 33133

FOLIO NUMBER: 03-4120-006-0950

This is to certify that the attached ownership list, map and mailing labels are a complete and accurate representation of the real estate property and property owners within 1,000 feet radius of the external boundaries of the subject property listed above, including the subject property. This reflects the records on file in the Miami-Dade County Property Appraisers' Office as of 8/1/2023. I affirm the notices were mailed on 8/7/2023.

Per Section 15-102: Should the radius extend beyond the City limits, notice shall be mailed outside of the City limits only to addresses that are known by reference to the latest ad valorem tax record that are within a five hundred (500) foot radius of the property that is the subject of the application.

The MDCPS Office of the Superintendent, the Principal of the MDCPS physically located within the notice area, the District 6 School Board Member, the School Board Chair and Vice Chair have been added to the list and mailing labels as per City of Coral Gables Res. 2020-245, if applicable.

Per Ordinance 2023-02, Section 15-102: All required mail notice will be sent to the property address and the mailing address per the Miami-Dade Country Property Appraisers website. If the address is the same for both, then only one notice must be sent.

Sincerely,

Diana B. Rio

Total number of property owners without repetition: **244, including 0 international* ****

**Includes the MDCPS Office of the Superintendent, the Principal of the MDCPS physically located within the notice area, the District 6 School Board Member, the School Board Chair and Vice Chair have been added to the list and mailing labels as per City of Coral Gables Res. 2020-245.*

***Properties outside of the City of Coral Gables boundaries were found within a 500' radius.*

Rio Development Resources, LLC ("RDR") has used its best efforts in collecting the information published in this report and the findings contained in the report are based solely and exclusively on information provided by you and information gathered from public records and that local government. By acceptance of this report, you agree to hold RDR harmless and indemnify RDR from any and all losses, damages, liabilities and expenses which can be claimed against RDR caused by or related to this report.



City of Coral Gables
Development Services Department

Affidavit Attesting to Public Notice of Zoning Application

Property Owner or Authorized Representative: Diana Rio
Property Address and Folio Number(s):

SUBJECT: 141 Grand Avenue, Coral Gables, FL 33133
FOLIO NUMBER: 03-4120-006-0950

I, as property owner or Authorized Representative of the above described property attest that on (date) 8/7/2023, I sent by U.S. Mail to each person on the list of names and addresses attached a true copy of the attached notice letter. I further attest that I have complied with the requirements of Resolution No. 2020-245 and Resolution No. 2020-265 (requiring additional notice to Miami-Dade County Public Schools "MDCPS") as indicated below:

- This application required notice to be sent to MDCPS and I have complied with the additional notice requirements in Resolutions No. 2020-245 and 2020-265.
- This application did not require notice to be sent to MDCPS.

I HEREBY CERTIFY that all information contained in this Affidavit is true and accurate. Under penalty of perjury, I declare that I have read the foregoing document and that the facts stated in it are true. Further, I acknowledge that I am subject to the City's False Claims Ordinance (Ch. 39, City of Coral Gables Code).

Affiant's Printed Name: Diana Rio

Affiant's Signature:  Date: 8/7/2023

Notary Public Affirmation

SWORN AND SUBSCRIBED before me, this 7th day of August, 20 23, personally appeared Diana Rio, being personally known to me or having produced as identification _____, and who being fully sworn and cautioned, states that the foregoing is true and correct to the best of his/her knowledge and belief.

Signature of Notary: 

Print Name: Mabel Rio

Notary Public Stamp:

My Commission Expires: 12-15-2023



Mabel Rio
Comm. # GG939791
Expires: Dec. 15, 2023
Bonded Thru Aaron Notary

141 Grand Avenue – Conditional Use – Community Meeting

Thursday, August 18, 2023, at 6:00 PM at 141 Grand Avenue

Minutes

6:15 PM

Introductions and PowerPoint presentation by Applicant (Joe Lindsay, Stephan Koetzle and Ian Bravo) and Applicant's counsel (Eddy Baker)

6:30 PM-7:15 PM

Questions and answers

Q: Will the cars leaving the rear parking lot of the school turn right onto Jefferson Street to access US-1?

A: Yes, nine cars will be dispersed through Florida Avenue and Frow Avenue.

Q: What about security?

A: All doors will be locked. All students leave the building with a teacher or aide. We have cameras showing all of the building and surrounding area. We have sensors on all of the doors. We have a great relationship with the Coral Gables Police Department and are in constant communication with them.

Q: Is the rear parking lot used for teachers?

A: The teachers will park at the off-site locations.

Q: Are enrolled students from the neighborhood?

A: Typical student is within 15-30 minutes of the school. We believe that 5-6 students will be within walking distance.

Q: Where will students eat their lunch?

A: In the classroom. On occasion they may eat their lunch at the park if it is nice outside.

Q: I see parents lining up on Grand Avenue and idling. What are you doing to reduce this?

A: We will be using the rear parking lot and two-off site locations so cars are getting off of Grand Avenue.

Q: I would suggest that you establish a relationship with the City of Miami Police Department too. I can give you the Commander's contact information.

A: We will definitely be in touch with them.

Q: How will you prevent parents from Carver from parking at your off-site locations and in the rear parking lot?

A: We will enforce towing if necessary and have very clear signage.

Q: Can you support the 4-way stop sign proposals that we have for the neighborhood.

A: Yes, we will gladly support this initiative.

Q: Can you bus students in?

A: We are not planning on bussing students in but will be encouraging carpooling.

Q: What about private transportation companies?

A: We do not have plans to partner with any private transportation companies.

Q: Who will residents contact if there are issues?

A: Stephan Koetzle, who handles our on the ground operations.

Q: Do you have testimonials from students and parents?

A: Yes, we have these on our website.

Q: Do you help transition students to high school?

A: Yes, we help students apply.

Q: Do all students have to pay?

A: Yes, but the majority of our students have their tuition subsidized by us through our foundation and the Florida programs. We have a sliding tuition scale based on income level. Tuition is \$18,500 sticker price with no financial aid or Florida programs. Very few students pay full price. Some students pay \$0 per year.

Q: How much of school curriculum is bound by Florida standards?

A: None because we are a private school.



1,000' RADIUS MAP (N.T.S.)

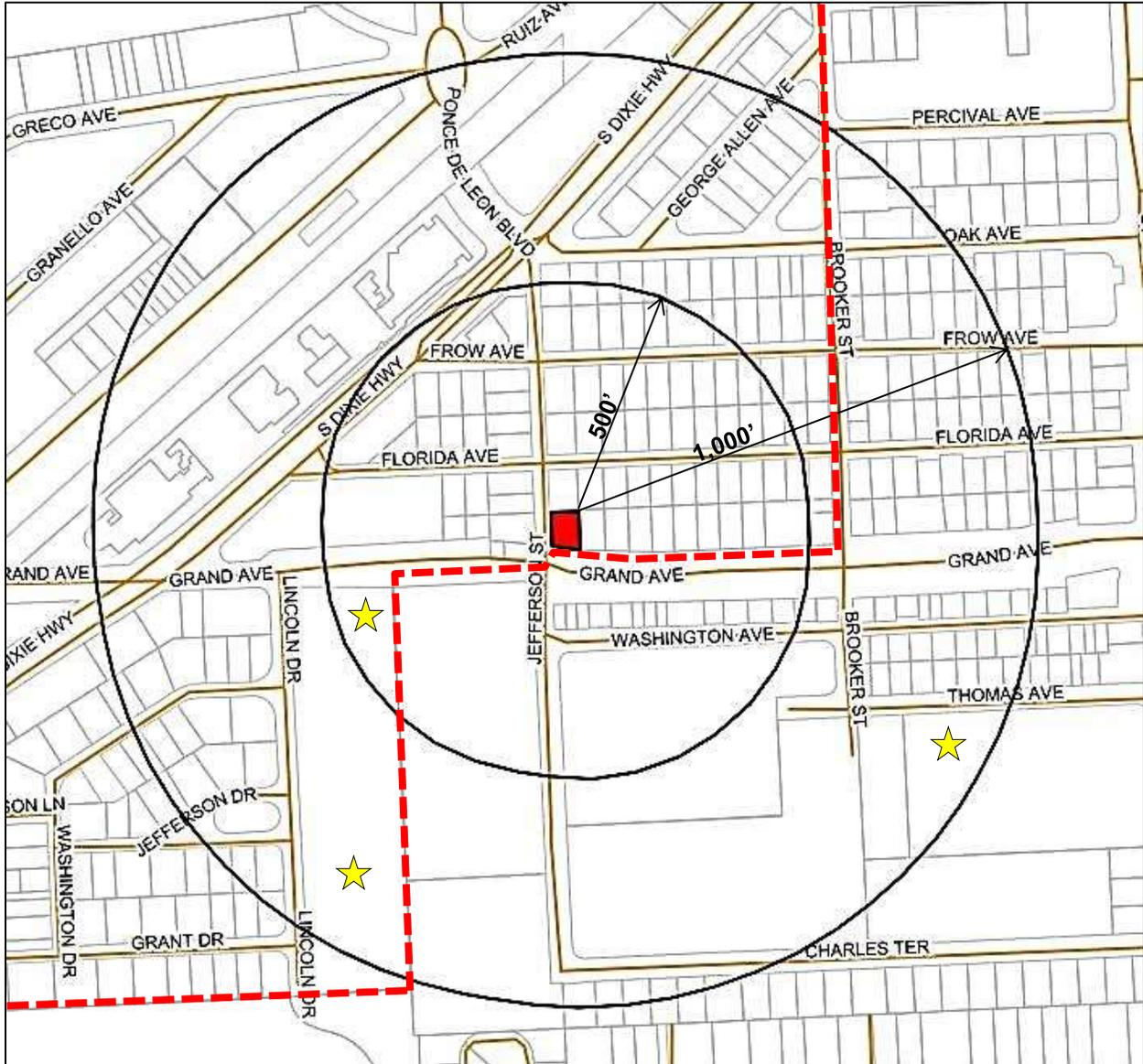

SUBJECT: 141 Grand Avenue, Coral Gables, FL 33133

FOLIO NUMBER: 03-4120-006-0950

LEGEND, IF APPLICABLE:

CITY OF CORAL GABLES BOUNDARY - - - - -

MDCPS ★

	City of Coral Gables Public Hearing Notice	
Applicant:	Spark Learning, Inc., DBA Spark Learning XIV.	
Application:	Conditional Use	
Property:	141 Grand Avenue	
Public Hearing - Date/Time/ Location:	PLANNING & ZONING BOARD Wednesday, October 11, 2023, 6:00 p.m. City Commission Chambers, City Hall, 405 Biltmore Way, Coral Gables, Florida, 33134 e-comments: www.CoralGables.GranicusIdeas.com/meetings	

PUBLIC NOTICE is hereby given that the City of Coral Gables, Florida, Planning and Zoning Board will conduct a Public Hearing on **Wednesday, October 11, 2023** on the following applications at the Coral Gables City Commission Chambers, City Hall, 405 Biltmore Way, Coral Gables, Florida:

A Resolution of the City Commission of Coral Gables, Florida granting conditional use approval pursuant to Zoning Code Article 14, "Process," Section 14-203, "Conditional Uses" for a School on a property zoned as Mixed-Use-1 (MX1) located at 141 Grand Avenue, Coral Gables, Florida; providing for a repealer provision, severability clause, and an effective date.

A conditional use application has been submitted by Mr. Edward Baker on behalf of Spark Learning, Inc., DBA Spark Learning XIV (the "Applicant") to the City of Coral Gables for a proposed school on a property zoned as Mixed-Use 1 (MX1). The Applicant seeks to operate the school to serve approximately 35 students, between the third to eighth grade, who are taking virtual core classes with Primer Microschool teachers. Students will be supervised and assisted by an educator, who has former professional experience as a teacher or homeschooler.

The application request requires review and recommendation by the Planning and Zoning Board at one (1) public hearing, and consideration by the City Commission at one (1) public hearing (Resolution format).

Additional information may be found at www.coralgables.com. Please forward to other interested parties.

The meeting will also be via Zoom at www.zoom.us/j/83788709513. A dedicated phone line will also be available by dialing: (305) 461-6769, Meeting ID: 837 8870 9513.

Sincerely,

City of Coral Gables, Florida

MIAMI-DADE

**STATE OF FLORIDA
COUNTY OF MIAMI-DADE:**

Before the undersigned authority personally appeared GUILLERMO GARCIA, who on oath says that he or she is the DIRECTOR OF OPERATIONS, Legal Notices of the Miami Daily Business Review f/k/a Miami Review, of Miami-Dade County, Florida; that the attached copy of advertisement, being a Legal Advertisement of Notice in the matter of

CITY OF CORAL GABLES - PUBLIC HEARING - LOCAL PLANNING AGENCY / PLANNING AND ZONING BOARD - OCT. 11, 2023

in the XXXX Court, was published in a newspaper by print in the issues of Miami Daily Business Review f/k/a Miami Review on

09/29/2023

Affiant further says that the newspaper complies with all legal requirements for publication in chapter 50, Florida Statutes.

Guillermo Garcia

Sworn to and subscribed before me this 29 day of SEPTEMBER, A.D. 2023

Barbara Thomas

(SEAL)

GUILLERMO GARCIA personally known to me

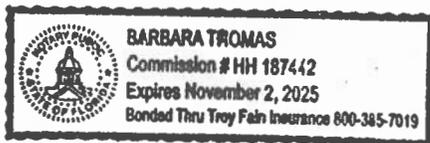

**CITY OF CORAL GABLES, FLORIDA
NOTICE OF PUBLIC HEARING
HYBRID MEETING ON ZOOM PLATFORM**

City Public Hearing Dates/Times	Local Planning Agency / Planning and Zoning Board Wednesday, October 11, 2023, 6:00 p.m.
Location	City Commission Chamber, City Hall 405 Biltmore Way, Coral Gables, FL 33134

PUBLIC NOTICE is hereby given that the City of Coral Gables, Florida, Local Planning Agency (LPA)/ Planning and Zoning Board (PZB) will conduct Public Hearing on the following:

1. An Ordinance of the City Commission of Coral Gables, Florida providing for a text amendment to Article 2 "Zoning Districts," Section 2-405 "Residential Infill Regulations Overlay District (RIR)" of the City of Coral Gables Official Zoning Code to provide a maximum building length of three hundred feet for all properties seeking approval pursuant to the Residential Infill Regulations; providing for severability, repealer, codification, and an effective date. (07 12 23 PZB meeting - deferred by Applicant; 09 21 23 PZB meeting - deferred by PZB)
2. A Resolution of the City Commission of Coral Gables, Florida granting conditional use approval pursuant to Zoning Code Article 14, "Process," Section 14-203, "Conditional Uses" for a School on a property zoned as Mixed- Use-1 (MX1) located at 141 Grand Avenue, Coral Gables, Florida; providing for a repealer provision, severability clause, and an effective date.

10/11/2023

3. An Ordinance of the City Commission of Coral Gables, Florida providing for text amendments to the City of Coral Gables Official Zoning Code (Zoning Code), amending Article 10, "Parking and Access," Section 10-112 "Miscellaneous Parking Standards," creating provisions for considering reduction of parking requirements for affordable housing located near a major transit stop as required by the Live Local Act, Ch. 2023-17, Laws of Florida; providing for repealer provision, severability clause, codification, and providing for an effective date.
4. An Ordinance of the City Commission of Coral gables, Florida, providing for text amendments to the City of Coral Gables Official Zoning Code, Article 6, "Landscape," by amending the utilization of artificial turf on open joints of pavement; and Article 10, "Parking and Access," by providing review of materials in pavement joints; and providing for a repealer provision, severability clause, codification, and an effective date.
5. An Ordinance of the City Commission of Coral Gables, Florida, providing for text amendments to the City of Coral Gables Official Zoning Code, Article 2, "Zoning districts," Section 2-403, "Giralda Plaza District Overlay," by allowing a television screen on the inside of a window on the pedestrian street of Giralda Plaza; providing for severability, repealer, codification, and for an effective date.

The Planning and Zoning Board will be holding its board meeting on Wednesday, October 11, 2023, commencing at 6:00 p.m. Pursuant to Resolution No. 2021-118, the City of Coral Gables has returned to traditional in-person meetings. However, the City Commission has established the ability for the public to virtually provide sworn testimony or public comments (non-sworn and without evidentiary value). Any individual who wishes to provide sworn testimony virtually must have their video on and must be sworn in.

Members of the public may join the meeting via Zoom at (<https://zoom.us/j/83788709513>). In addition, a dedicated phone line will be available so that any individual who does not wish (or is unable) to use Zoom may listen to and participate in the meeting by dialing: (305) 461-6769 Meeting ID: 837 8870 9513. The public may comment on an item using the City's E-Comment function which may be found on the City's website at: (<https://coralgables.granicusideas.com/meetings>) once the meeting's agenda is published, or by sending an email to planning@coralgables.com prior to the meeting.

The meeting will also be broadcasted live for members of the public to view on the City's website (www.coralgables.com/cqtv) as well as Channel 77 on Comcast.

Sincerely,
City of Coral Gables, Florida
9/29

23-57/0000686170M

2/2



141 Grand Avenue

CONDITIONAL USE - SCHOOL

PLANNING AND ZONING BOARD
OCTOBER 11, 2023



1

LOCATION

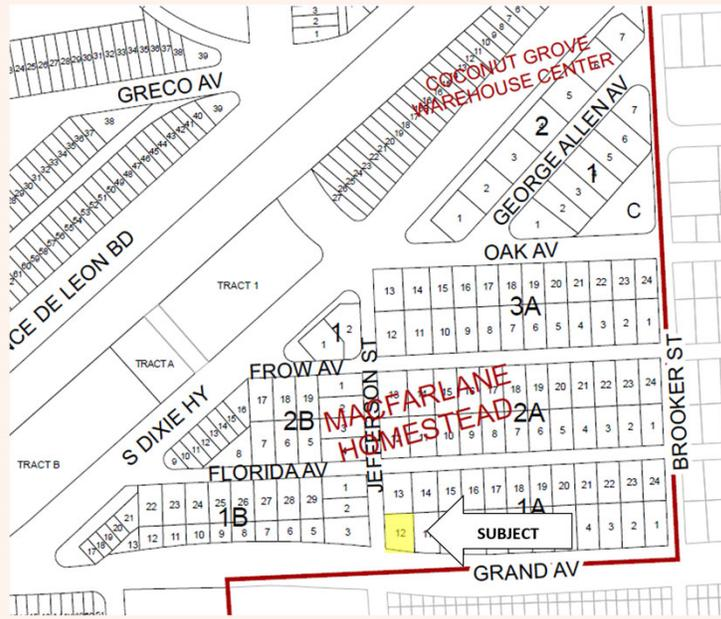

2

2

141 GRAND AVENUE

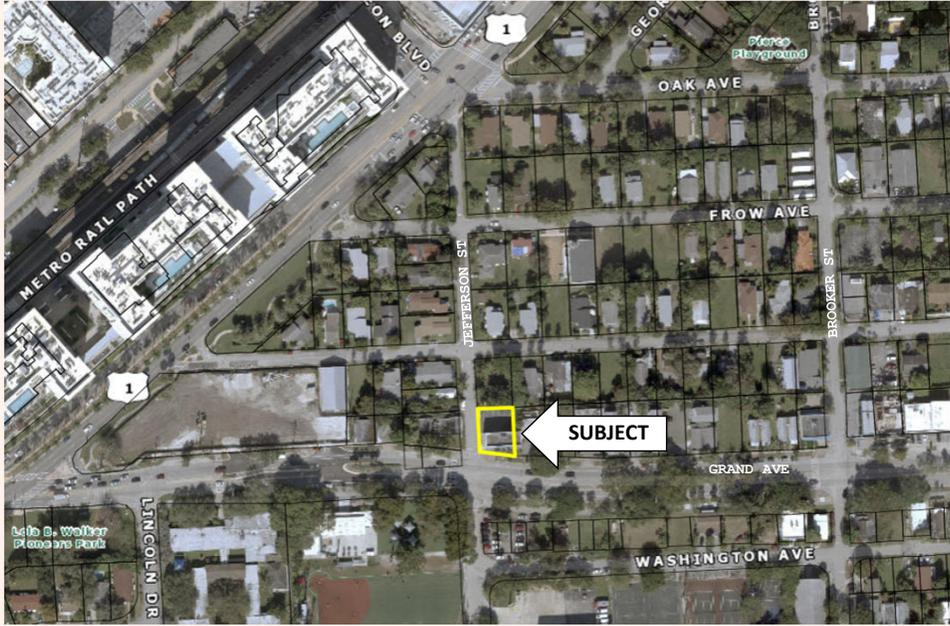

3

LAND USE AND ZONING MAPS

Future Land Use: Commercial Low-Rise Intensity

Zoning: Mixed Use 1 (MX1)

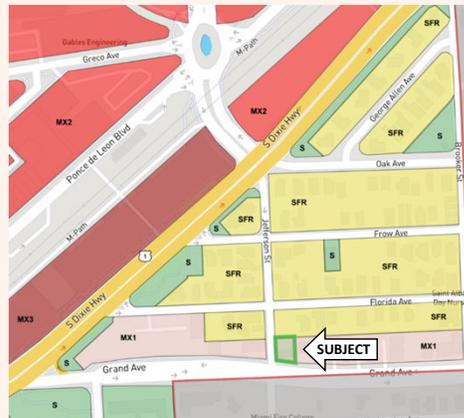

4

4

SITE PLAN

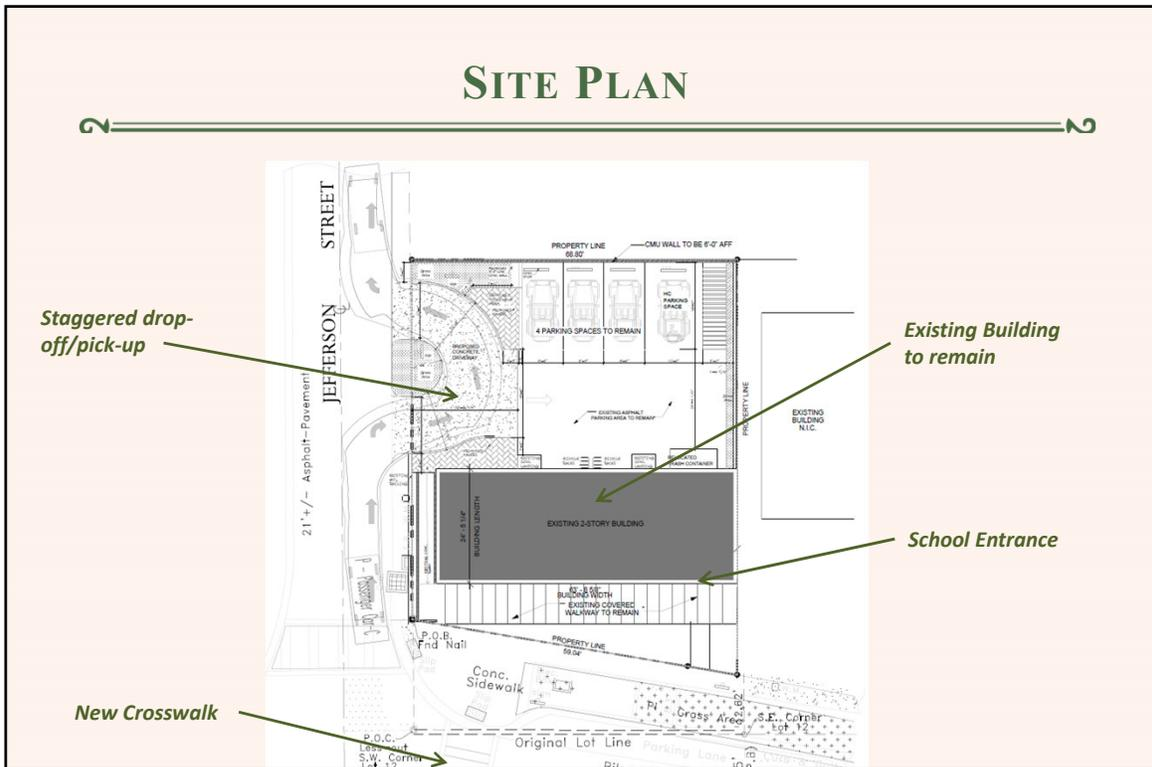

5

TRAFFIC/PARKING OPERATIONS

The aerial map shows the school site at 141 Grand Avenue, flanked by Offsite Area A (Faculty Parking Only) at 213 & 215 Grand Avenue to the west and Offsite Area B at 127 Grand Avenue to the east. Jefferson Street runs north-south through the site. A pedestrian path (Ped.) is shown connecting the school site to Offsite Area B. A dashed line indicates a route from Offsite Area B to the school entrance.

Staggered Schedule				
Time	141 Grand Ave. (School Site) 4 Car Capacity	127 Grand Ave. (Site B) 4 Car Capacity	Total	
Morning	7:00 AM	2	3	5
	7:10 AM	2	4	6
	7:20 AM	3	3	6
	7:30 AM	2	4	6
	7:40 AM	2	3	5
	7:50 AM	3	4	7
	TOTAL	14	21	35
Afternoon	3:00 PM	2	3	5
	3:10 PM	2	4	6
	3:20 PM	3	3	6
	3:30 PM	2	4	6
	3:40 PM	2	3	5
	3:50 PM	3	4	7
	TOTAL	14	21	35

NOTES:
 1- Parents or school personnel will walk students from remote parking area "B" to and from the school entrance.
 2- Parents will be assigned a drop-off/pick-up location "B" and designated/scheduled time.

6

REVIEW TIMELINE

1	DEVELOPMENT REVIEW COMMITTEE: 04.28.23
2	NEIGHBORHOOD MEETING: 08.18.23
3	PLANNING AND ZONING BOARD: 10.11.23
4	CITY COMMISSION: TBD

7

7

LETTERS TO PROPERTY OWNERS (1,000 FT)

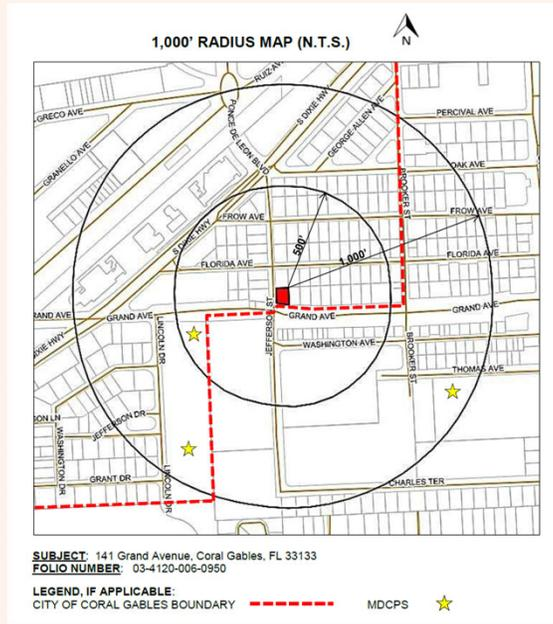

8

8

PUBLIC NOTIFICATION	
2 TIMES	LETTERS TO PROPERTY OWNERS NEIGHBORHOOD MEETING, PZB
2 TIMES	PROPERTY POSTING DRC, PZB
2 TIMES	WEBSITE POSTING DRC, PZB
1 TIME	NEWSPAPER ADVERTISEMENT PZB

9

STAFF RECOMMENDATION

STAFF’S DETERMINATION IS THAT THIS APPLICATION IS **CONSISTENT** WITH THE COMPREHENSIVE PLAN GOALS, OBJECTIVES AND POLICIES AND **SATISFIES** ALL STANDARDS.

STAFF RECOMMENDS **APPROVAL WITH CONDITIONS.**

10

CONDITIONS OF APPROVAL

- **35 STUDENTS, GRADES 3RD TO 8TH, 8AM – 3PM**
- **DROP-OFF IS 7-8AM, PICK-UP IS 3-4PM**
- **ON-SITE IS ONLY DROP-OFF/PICK-UP**
- **OFF-SITE B IS LIMITED TO DROP OFF/PICK UP**
- **OFF-SITE A IS LIMITED TO FACULTY/EMPLOYEE PARKING**
- **POLICE OFFICER FOR FIRST 3 MONTHS OF EACH SCHOOL YEAR;
ABILITY TO PETITION CITY TO REMOVE REQUIREMENT EACH YEAR**
- **OFF-SITE AGREEMENTS RENEWED AT THE ANNUAL RENEWAL OF
CERTIFICATE OF USE**
- **INSTALL NEW CROSSWALK AND OTHER PUBLIC REALM IMPROVEMENTS**

11



141 Grand Avenue

CONDITIONAL USE - SCHOOL

PLANNING AND ZONING BOARD
OCTOBER 11, 2023



12