

211 North Lindbergh Blvd.  
Suite 200  
St. Louis, MO 63141

314-535-5005 tel  
314-754-0835 fax

anovafurnishings.com

8/20/19

RE: City of Coral Gables, FL IFB 2019-033

Trash and Recycling Receptacles

Anova Furnishings contact information

Manuel Gil-Goodman - Territory Development - South Florida

Mobile - 786.385.7101

Email - [Manuel.G@Anovafurnishings.com](mailto:Manuel.G@Anovafurnishings.com)

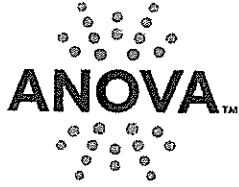

211 North Lindbergh Blvd.  
Suite 200  
St. Louis, MO 63141

314-535-5005 tel  
314-754-0835 fax

anovafurnishings.com

## Table of Contents

City of Coral Gables, FL IFB 2019-033

- Bidders acknowledgement - 3
- Solicitation Submission Checklist - 4
- Florida Business License - 5,6
- Florida Resale Certificate - 7
- References - 8
- Product Information/Install Instructions - 9,10,11,12,13
- Bid Pricing Form - 14
- Contractors Affidavit and Schedules -15,16,17,18,19,20,21,22

3

# CITY OF CORAL GABLES, FL

2800 SW 72<sup>nd</sup> Avenue, Miami, FL 33155  
Finance Department / Procurement Division  
Tel: 305-460-5102/ Fax: 305-261-1601



## BIDDER ACKNOWLEDGEMENT

<p><b>IFB Title: Trash and Recycling Receptacles</b></p> <hr/> <p><b>IFB No. 2019-033</b></p> <p>A cone of silence is in effect with respect to this IFB. The Cone of Silence prohibits certain communication between potential vendors and the City. For further information, please refer to the City Code Section 2-1027 of the City of Coral Gables Procurement Code.</p>	<p>Sealed bid submittals must be received prior to <b>2:00 p.m., Wednesday, September 4, 2019</b>, by the Procurement Division, located at 2800 SW 72<sup>nd</sup> Avenue, Miami, FL 33155 and are to remain valid for 90 calendar days. Submittals received after the specified date and time will be returned unopened.</p> <p>Contact: Eduardo Hernandez Title: Procurement Specialist Telephone: 305-460-5108 Email: <a href="mailto:ehernandez2@coralgables.com">ehernandez2@coralgables.com</a> / <a href="mailto:contracts@coralgables.com">contracts@coralgables.com</a></p>
---	--

Bidder Name: Anova Furnishings	FEIN or SS Number: 43-0957292
Complete Mailing Address: 211 N. Lindbergh Blvd St Louis MO 63141	Telephone No. 314 755-1212
Indicate type of organization below: Corporation: <input checked="" type="checkbox"/> Partnership: <input type="checkbox"/> Individual: <input type="checkbox"/> Other: <input type="checkbox"/>	Cellular No. 786-385-7101
Bid Bond / Security Bond (if applicable) <u>N/A</u> %	Fax No.: 314-755-1213 Email: <a href="mailto:Manuel.G@Anovafurnishings.com">Manuel.G@Anovafurnishings.com</a>

**ATTENTION: THIS FORM ALONG WITH ALL REQUIRED IFB FORMS MUST BE COMPLETED, SIGNED (PREFERABLY IN BLUE INK), AND SUBMITTED WITH THE BID PRIOR TO THE SUBMITTAL DEADLINE. FAILURE TO DO SO MAY DEEM YOUR BID NON-RESPONSIVE.**

THE BIDDER CERTIFIES THAT THIS SUBMITTAL IS BASED UPON ALL CONDITIONS AS LISTED IN THE IFB DOCUMENTS AND THAT THE BIDDER HAS MADE NO CHANGES IN THE IFB DOCUMENT AS RECEIVED. THE BIDDER FURTHER AGREES, IF THE BID IS ACCEPTED, THE BIDDER WILL EXECUTE AN APPROPRIATE AGREEMENT FOR THE PURPOSE OF ESTABLISHING A FORMAL CONTRACTUAL RELATIONSHIP BETWEEN THE BIDDER AND THE CITY OF CORAL GABLES, FOR THE PERFORMANCE OF ALL REQUIREMENTS TO WHICH THIS IFB PERTAINS. FURTHER, BY SIGNING BELOW PREFERABLY IN BLUE INK ALL IFB PAGES ARE ACKNOWLEDGED AND ACCEPTED, AS WELL AS, ANY SPECIAL INSTRUCTION SHEET(S), IF APPLICABLE. THE UNDERSIGNED HEREBY DECLARES (OR CERTIFIES) ACKNOWLEDGEMENT OF THESE REQUIREMENTS AND THAT HE/SHE IS AUTHORIZED TO BIND PERFORMANCE OF THIS IFB FOR THE ABOVE BIDDER.

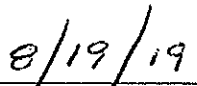
\_\_\_\_\_ Title \_\_\_\_\_ Date \_\_\_\_\_  
 Authorized Name (and Signature)

Coral Gables Local Preference Acknowledgement. (Check the box if you are asserting you qualify. A valid Coral Gables business tax receipt must be submitted as proof of qualification.) Please refer to Ordinance 2009-53, § 2, 11-17-2009/Procurement Code Sec. 2-696

# SOLICITATION SUBMISSION CHECKLIST

## Invitation for Bids (IFB) No 2019-033

COMPANY NAME: (Please Print): <u>Anova Furnishings</u>	
Phone: <u>314-755-1212</u>	Email: <u>Manuel.G@anovafurnishings.com</u>

**A SEPARATE response package numbered by page must be submitted. Please provide the PAGE NUMBER of your separate solicitation response (PLEASE DO NOT SUBMIT AN ENTIRE COPY OF THE ORIGINAL SOLICITATION) in the blanks provided as to where compliance information is located in your Submittal for each of the required submittal items listed below:**

- 1) Title Page: Show the IFB number and title, ~~the~~ name of your firm, address, telephone number, name of contact person, e-mail address, and date. ✓
- 2) Provide a Table of Contents in accordance with the Bid Format, Section 6.2. Clearly identify the material by section and page number. Please insert *additional TABS* on the following sections in the Original Bid Copy: Bid Bond (if applicable), Bid Pricing Form and Addendum Acknowledgement. ✓
- 3) Fill out, sign, and submit the Bidder's Acknowledgement Form. ✓
- 4) Fill out and submit this Solicitation Submission Checklist. ✓
- 5) Minimum Qualification Requirements: submit detailed verifiable information affirmatively documenting compliance with the Minimum Qualifications Requirements shown in Section 3. ✓
- 6) Product information: provide product information literature including pictures, drawings, technical specifications, and standard color chart.
- 7) Bid Pricing Form: Complete and submit with bid. ✓
- 8) Fill out, sign, notarize, and submit the Contractor's Affidavit and Schedules A through H. ✓

### -- NOTICE --

#### BEFORE SUBMITTING YOUR BID MAKE SURE YOU...

1. Carefully read and have a clear understanding of the IFB, including the Specifications/Scope of Work and enclosed Contract or Professional Services Agreement (*draft*).
2. Carefully follow the "Submittal Instructions" and "Bid Format" outlined in Section 6 of the IFB and provide a SEPARATE response package. DO NOT INCLUDE A COPY OF THE ORIGINAL SOLICITATION.
3. Prepare and submit ONE (1) ORIGINAL BID and ONE (1) PHOTOCOPY with ONE (1) DIGITAL COPY CD or flash drive.
4. Clearly mark the following on the outside of your submittal package: IFB Number, IFB Title, Bidder's Name and Return Address, Submittal Deadline.
5. Make sure your bid is submitted prior to the submittal deadline. **Late bids will not be accepted.**

**FAILURE TO SUBMIT THIS CHECKLIST AND THE REQUESTED DOCUMENTATION MAY RENDER YOUR BID NON-RESPONSIVE AND CONSTITUTE GROUNDS FOR REJECTION. THESE PAGES MUST BE RETURNED WITH YOUR BID PACKAGE.**



[Department of State](#) / [Division of Corporations](#) / [Search Records](#) / [Detail By Document Number](#) /

### Detail by Entity Name

Foreign Profit Corporation  
ANOVA FURNISHINGS, INC.

Filing Information

<b>Document Number</b>	F13000000676
<b>FEI/EIN Number</b>	43-0957292
<b>Date Filed</b>	02/13/2013
<b>State</b>	MO
<b>Status</b>	ACTIVE
<b>Last Event</b>	REINSTATEMENT
<b>Event Date Filed</b>	03/12/2015

Principal Address

211 N. LINDBERGH BLVD.  
SUITE 200  
ST LOUIS, MO 63141

Changed: 01/16/2019

Mailing Address

211 N. LINDBERGH BLVD.  
SUITE 200  
ST LOUIS, MO 63141

Changed: 01/16/2019

Registered Agent Name & Address

CORPORATION SERVICE COMPANY  
1201 HAYS STREET  
TALLAHASSEE, FL 32301

Name Changed: 03/12/2015

Officer/Director Detail

**Name & Address**

Title Director

GILBERT, WILLIAM  
609 S. WARSON RD  
ST LOUIS, MO 63124

Title VP Director



Title VP, Director

GILBERT, HELEN  
609 S. WARSON RD  
ST LOUIS, MO 63124

Title President, Director

GILBERT, ERIC  
211 N. LINDBERGH BLVD.  
ST LOUIS, MO 63141

Title Treasurer

Kunz, Ken  
211 N. LINDBERGH BLVD.  
ST LOUIS, MO 63141

Title CONTROLLER

CURRY, MIKE  
211 N. LINDBERGH BLVD.  
SUITE 200  
ST LOUIS, MO 63141

**Annual Reports**

Report Year	Filed Date
2017	02/13/2017
2018	01/10/2018
2019	01/16/2019

**Document Images**

<a href="#">01/16/2019 -- ANNUAL REPORT</a>	<a href="#">View image in PDF format</a>
<a href="#">01/10/2018 -- ANNUAL REPORT</a>	<a href="#">View image in PDF format</a>
<a href="#">02/13/2017 -- ANNUAL REPORT</a>	<a href="#">View image in PDF format</a>
<a href="#">01/29/2016 -- ANNUAL REPORT</a>	<a href="#">View image in PDF format</a>
<a href="#">06/18/2015 -- AMENDED ANNUAL REPORT</a>	<a href="#">View image in PDF format</a>
<a href="#">03/12/2015 -- REINSTATEMENT</a>	<a href="#">View image in PDF format</a>
<a href="#">02/13/2013 -- Foreign Profit</a>	<a href="#">View image in PDF format</a>



## 2019 Florida Annual Resale Certificate for Sales Tax

This Certificate Expires on December 31, 2019

DR-13  
R. 10/18

7

Business Name and Location Address

Certificate Number

ANOVA FURNISHINGS, INC  
1201 HAYS ST  
TALLAHASSEE, FL 32301-2699

47-8016107385-0

By extending this certificate or the certificate number to a selling dealer to make eligible purchases of taxable property or services exempt from sales tax and discretionary sales surtax, the person or business named above certifies that the taxable property or services purchased or rented will be resold or re-rented for one or more of the following purposes:

- Resale as tangible personal property.
- Re-rental as tangible personal property.
- Resale of services.
- Re-rental as commercial real property.
- Incorporation into tangible personal property being repaired.
- Re-rental as transient rental property.
- Incorporation as a material, ingredient, or component part of tangible personal property that is being produced for sale by manufacturing, compounding, or processing.

Your *Florida Annual Resale Certificate for Sales Tax* (Annual Resale Certificate) allows you or your representatives to buy or rent property or services tax exempt when the property or service is resold or re-rented. You **may not** use your Annual Resale Certificate to make tax-exempt purchases or rentals of property or services that will be used by your business or for personal purposes. Florida law provides for criminal and civil penalties for fraudulent use of an Annual Resale Certificate.

**As a seller**, you must document each tax-exempt sale for resale using one of three methods. You can use a different method each time you make a tax-exempt sale for resale.

1. Obtain a copy (paper or electronic) of your customer's current Annual Resale Certificate.
2. For each sale, obtain a transaction authorization number using your customer's Annual Resale Certificate number.
3. Each calendar year, obtain annual vendor authorization numbers for your regular customers using their Annual Resale Certificate numbers.

**Online:** Visit [floridarevenue.com/taxes/certificates](http://floridarevenue.com/taxes/certificates)

**Phone:** 877-357-3725 and enter your customer's Annual Resale Certificate number

**Mobile App:** Available for iPhone, iPad, Android devices, and Windows phones.



8

211 North Lindbergh Blvd  
Suite 200  
St. Louis, MO 63141  
314.535.5005 tel  
314.754.0835 fax

## ANOVA Municipal Project References

- City of Hallandale Beach  
Fernando Paiva  
954.457.1393  
[fpaiva@hallandalebeachfi.gov](mailto:fpaiva@hallandalebeachfi.gov)  
Ingalls Park Renovation
- City of Clayton  
Karen Herbig  
314.290.8572  
[kherbig@claytonmo.gov](mailto:kherbig@claytonmo.gov)  
Park Benches
- City of Brentwood  
Eric Gruenenfelder  
314.963.8681  
[egrueenfelder@brentwoodmo.org](mailto:egrueenfelder@brentwoodmo.org)  
Custom Trash Receptacles





211 North Lindbergh Blvd.  
 St. Louis, MO 63141  
 800.231.1327 tel. | 314.754.0835 fax  
[specify@anovafurnishings.com](mailto:specify@anovafurnishings.com)  
[anovafurnishings.com](http://anovafurnishings.com)

(9)

**L2019— Metrix Trash Receptacle with Dual Side Openings and Side Door**

40-gallon steel slat trash receptacle with contour top, plastic liner, rubber feet and optional recycle decal (when specified)

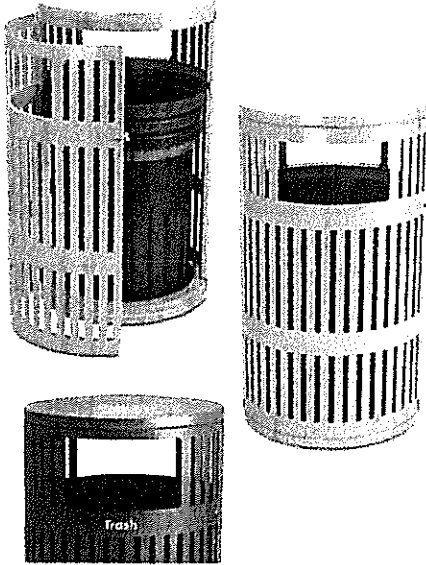

**Material**

The receptacle is 43.60" tall and is composed of 10-gauge slotted steel with a .63" gap vertical slotted pattern. The side door features a full-length, heavy-duty steel hinge and a tamper-resistant cam lock and key system. The receptacle has two 7.25" high and 13.29" wide waste openings located on opposite sides of each other. The contour top is made of 16-gauge galvanized steel.

Optional decals are available. Choose "Bottles/Cans" with recycling logo, "Mixed Recycling" with recycling logo or "Trash" decal—custom decals also available. Specify black or white lettering. Decals will be factory installed and must be specified at the time of order.

The receptacle is designed to be portable for flexibility in placement or surface mounted using pre-drilled 0.32" diameter holes inside the base to prevent movement. Mounting hardware is not included. The rubber feet are adjustable to assist in leveling the receptacle. The reusable plastic liner is made of high-density polyethylene.

**Finish**

Fade-resistant, powder coated steel features a state-of-the-art primer proven to prevent rusting. Treated components exceed the industry standard by 34% in testing by independent sources.

**Color**

See website or sales representative for color choices.

**Assembly**

The receptacle ships fully assembled and ready for use.

**Maintenance**

The product is virtually maintenance-free and requires only periodic cleaning with a sponge and a mild detergent and water solution to remove surface dirt. Do not clean with solvent or petroleum base products.

**Warranty**

20-year limited structural warranty with 7-year finish warranty against fading from the date of purchase. See full details on multi-year warranties for components at [www.anovafurnishings.com/warranty.aspx](http://www.anovafurnishings.com/warranty.aspx).

**Replacement Parts**

Black Plastic Liner R-DOM1012

**Decals**

- Trash w/Logo-White DEC2000
- Trash w/Logo-Black DEC2002
- Bottles/Cans w/Logo-White DEC2008
- Bottles/Cans w/Logo-Black DEC2010
- Mixed Recycling w/Logo-Whit DEC5000
- Mixed Recycling w/Logo-BLK DEC5002

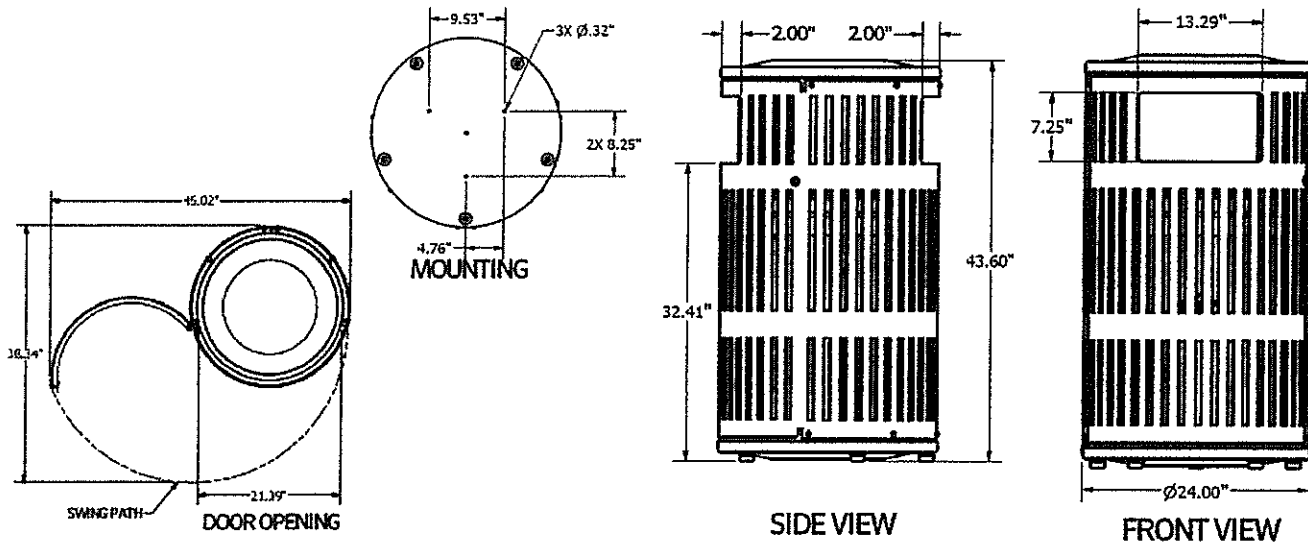

**SHIPPING INFORMATION**

Unit Weight	Unit Shipping Wt. UPS	Unit Shipping Wt. Truck (1+ Units)	Unit Ship Size w/Pallet	Max Units Per Pallet	Pallet Size/Wt. (32" x 48")	Total No. Pkgs.	Shipping Class
126 lbs.	N/A	137 lbs./unit	39 cu. ft.	4	50 lbs.	1	100

3/23/2017

Copyright 2017 ANOVA®

Made in USA.

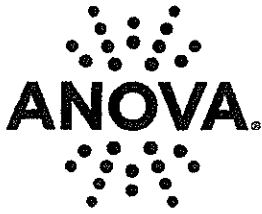

(10)  
 211 North Lindbergh Blvd.  
 St. Louis, MO 63141  
 800.231.1327 tel. | 314.754.0835 fax  
[specify@anovafurnishings.com](mailto:specify@anovafurnishings.com)  
[anovafurnishings.com](http://anovafurnishings.com)

**L2020— Matrix Recycler with Dual Side Openings and Side Door**

**40-gallon steel slat recycler with contour top, plastic liner, rubber feet and optional recycle decal (when specified)**

**Material**

The recycler is 43.60" tall and is composed of 10-gauge slotted steel with a .63" gap vertical slotted pattern. The side door features a full-length, heavy-duty steel hinge and a tamper-resistant cam lock and key system. The recycler has two 5" high and 5" wide recycle openings located on opposite sides of each other. The contour top is made of 16-gauge galvanized steel.

Optional decals are available. Choose "Bottles/Cans" with recycling logo, "Mixed Recycling" with recycling logo or "Trash" decal—custom decals also available. Specify black or white lettering. Decals will be factory installed and must be specified at the time of order.

The receptacle is designed to be portable for flexibility in placement or surface mounted using pre-drilled 0.32" diameter holes inside the base to prevent movement. Mounting hardware is not included. The rubber feet are adjustable to assist in leveling the receptacle. The reusable plastic liner is made of high-density polyethylene.

**Finish**

Fade-resistant, powder coated steel features a state-of-the-art primer proven to prevent rusting. Treated components exceed the industry standard by 34% in testing by independent sources.

**Color**

See website or sales representative for color choices.

**Assembly**

The receptacle ships fully assembled and ready for use.

**Maintenance**

The product is virtually maintenance-free and requires only periodic cleaning with a sponge and a mild detergent and water solution to remove surface dirt. Do not clean with solvent or petroleum base products.

**Warranty**

20-year limited structural warranty with 7-year finish warranty against fading from the date of purchase. See full details on multi-year warranties for components at [www.anovafurnishings.com/warranty.aspx](http://www.anovafurnishings.com/warranty.aspx).

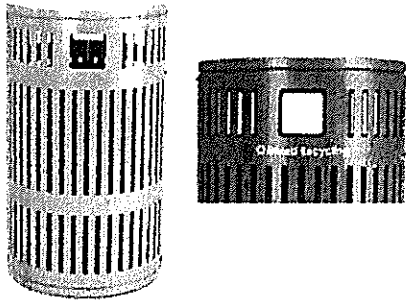
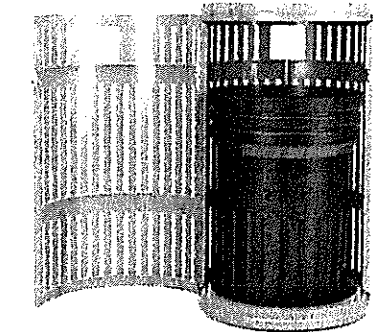

**Replacement Parts**

Black Plastic Liner R-DOM1012

**Decals**

- Trash w/Logo-White DEC2000
- Trash w/Logo-Black DEC2002
- Bottles/Cans w/Logo-White DEC2008
- Bottles/Cans w/Logo-Black DEC2010
- Mixed Recycling w/Logo-Whit DEC5000
- Mixed Recycling w/Logo-Blk DEC5002

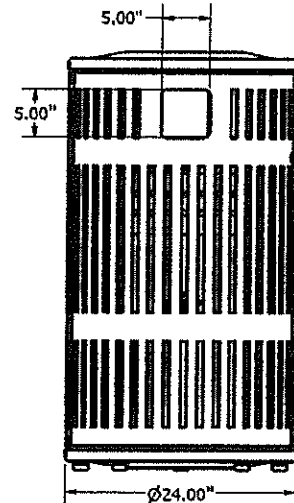
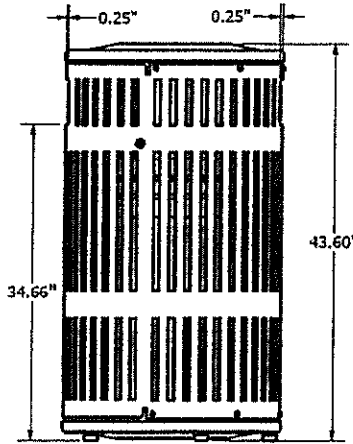
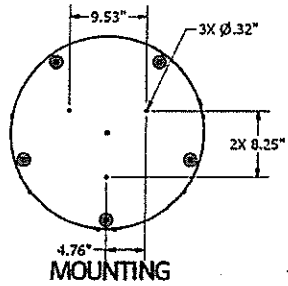
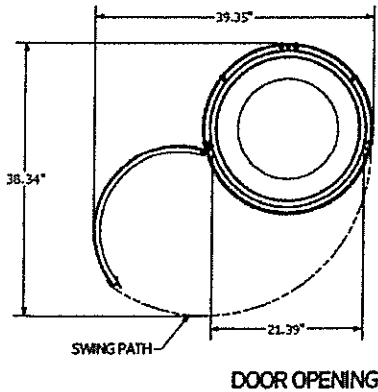

**SHIPPING INFORMATION**

Unit Weight	Unit Shipping Wt. UPS	Unit Shipping Wt. Truck (1+ Units)	Unit Ship Size w/Pallet	Max Units Per Pallet	Pallet Size/Wt. (32" x 48")	Total No. Pkgs.	Shipping Class
126 lbs.	N/A	137 lbs./unit	39 cu. ft.	4	50 lbs.	1	100



# Colors and Patterns

Colors may vary due to screen resolution and personal settings.  
For an exact match, please contact us to request a sample.

## HIGH-GLOSS COATED METALS

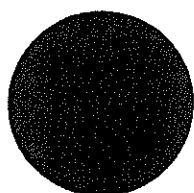

Black

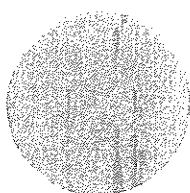

Gray

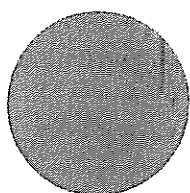

Sage

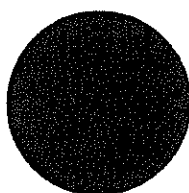

Pine

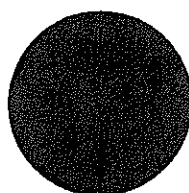

Navy

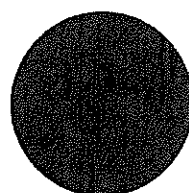

Blue

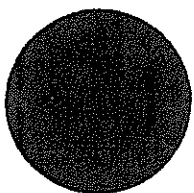

Brown

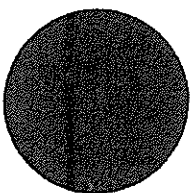

Burgundy

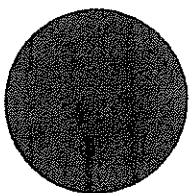

Red

## TEXTURED COATED METALS

\* Select colors may require an additional charge.

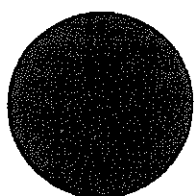

Textured Black

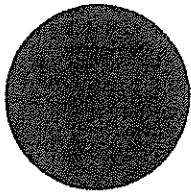

Textured Charcoal

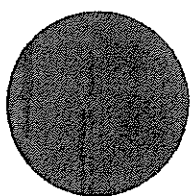

Textured Bronze

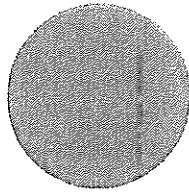

Textured Pewter

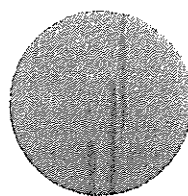

Textured Silver



Textured Sandstone

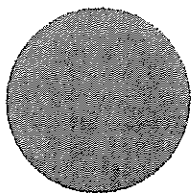

Textured White

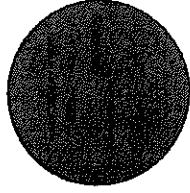

Textured Fern

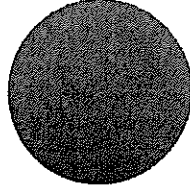

\*Textured Teal

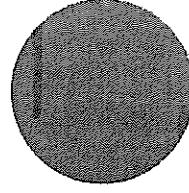

\*Textured Purple

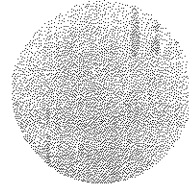

\*Textured Orange



\*Textured Yellow

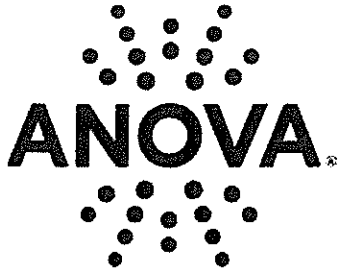

anovafurnishings.com  
888.535.5005 tel

# Installation Instructions

## Metrix Receptacles

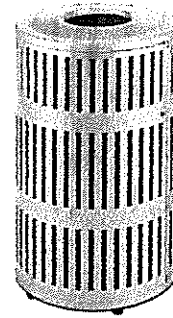
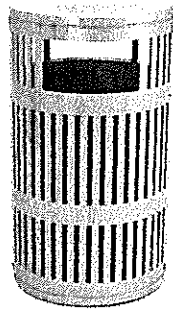

### TOOLS NEEDED:

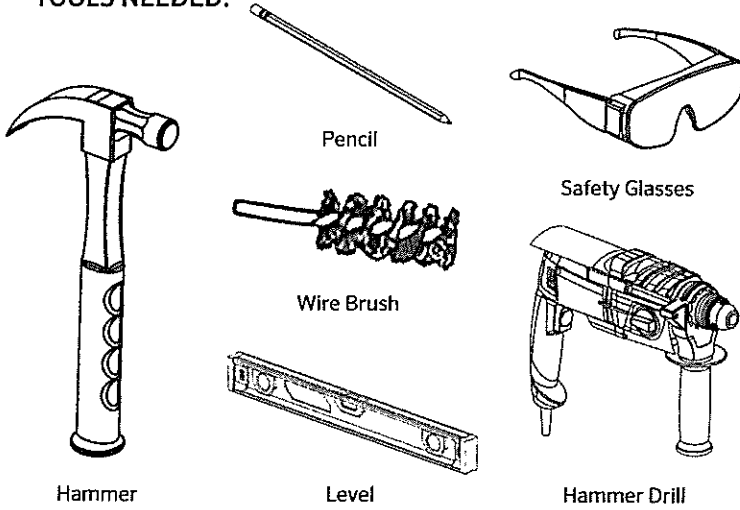

### PROVIDED SUPPLIES:

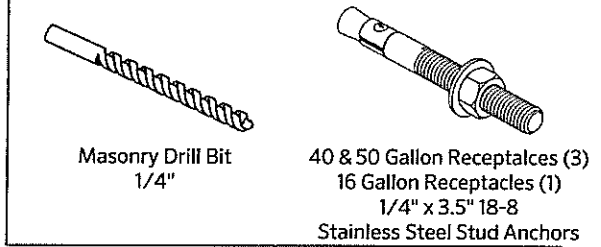

### OPTIONAL HARDWARE:

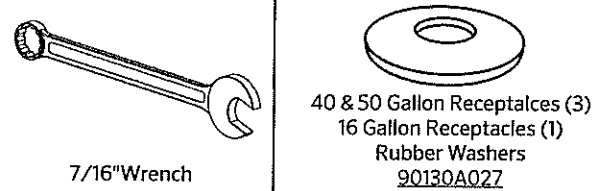

### Step-by-Step Installation Sequence

Product ships fully assembled.

Examine the footing or slab for damage or defects. The footing or slab should be reinforced concrete rated at a 3,000 psi minimum and be cured for at least 28 days prior to the installation of the receptacle.

**CAUTION:** Oversized holes and holes drilled too deep in the concrete will make it difficult to set the anchor.

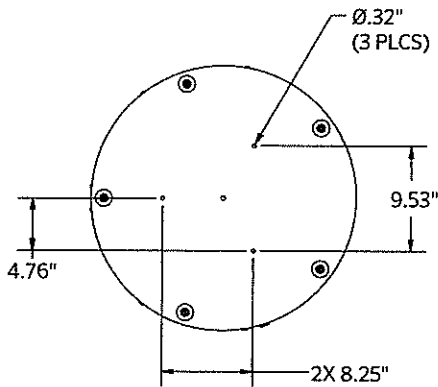

40 & 50 Gallon Receptacles

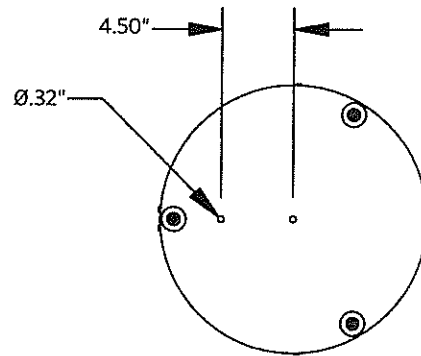

16 Gallon Receptacles

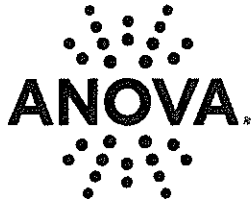

# Installation Instructions

## Metrix Gallon Receptacles

### Step-by-Step Installation Sequence

1. Place receptacle in the desired location. Mark the location of the holes with a pencil. To verify the alignment of the anchor markings you may reference the bottom of page 1.
2. ⚠ Drill holes with provided 1/4" drill bit and avoid drilling the holes too deep.
3. Evacuate debris from mounting holes using compressed air and a steel wire brush. This will create a clean environment for the anchor system.
4. Locate an anchor and adjust the nut so it is flush with the top of the anchor to protect the threads from being damaged. Insert the anchor into the hole.
5. Use the hammer to fix the anchor into the drilled hole by giving it several hammer blows.
6. Repeat steps 2 - 5 until all anchors are installed.
7. Remove the nuts and washers off of the anchors. Align the mounting holes of the receptacle over top of the anchors and slide it down into place.
8. ⚠ Care should be given to avoid rubbing the powder coating off the base. A 1/4" rubber washer is a suitable replacement option. Mount the receptacle to the ground by placing a washer and a nut onto each anchor. Leave the hardware finger tight until all of them have been installed. Verify that the receptacle is level before tightening the anchors. Tighten all of the hardware with a 7/16 wrench.

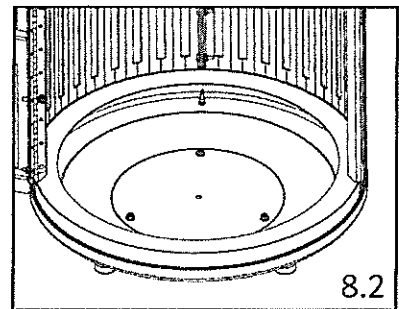
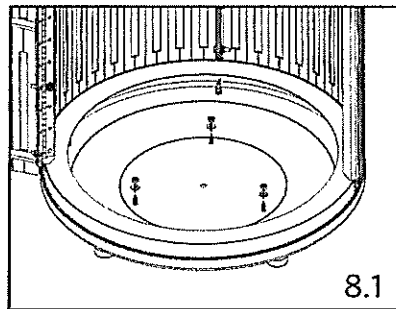
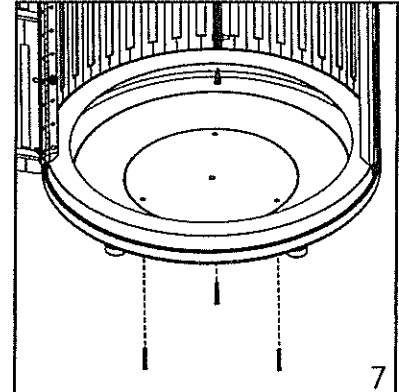
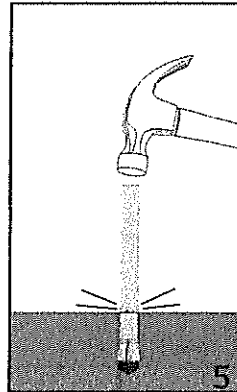
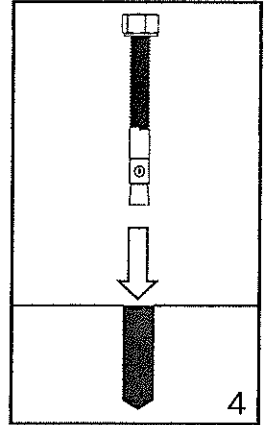
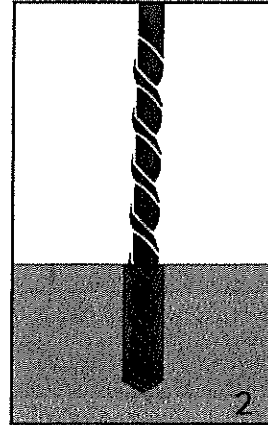

Note: Please contact Customer Care at 1-866-797-1761 when ordering replacement parts.



**WARNING**

- Furniture must not be used other than for its intended purposes and should be inspected regularly for loose, missing, or broken hardware, and general instability.
- Furniture that is damaged or appears to be unstable must be removed from service and be repaired or replaced.
- Repairs must be made using only factory authorized parts and methods.

### CARE AND MAINTENANCE

- Do not drag the assembled unit across any surface.
- This product requires only periodic cleaning with a sponge and a solution of mild detergent and water to remove surface dirt. Do not clean with a solvent or petroleum based products.

15

**BID PRICING FORM**

IFB 2019-033 Trash and Recycling Receptacles

The Bidder shall provide the following pricing. Pricing for all items is required. Failure to submit pricing for all components will render your submittal non-responsive.										
Item No.	Description	Estimated Quantity	Unit of Measure	Price Per Unit	Total Extended Price	Warranty Period (In Years)	Delivery Period A.R.O (In Days)	Picket Line Spacing (In Inches)	Manufacturer's Name Product/Model Number	Additional Information
1	Trash Receptacle Steel Powdercoated (including mounting hardware and signage)	100	Each	\$1178.30	\$117,830.00	5	60		Anova L2019	
2	Recycling Receptacle Steel Powdercoated (including mounting hardware and signage)	100	Each	\$1178.30	\$117,830.00	5	60		Anova L2020	
<b>Total:</b>					<b>\$235,660.00</b>					

NOTES: Please Complete All Shaded Areas  
Unit price per receptacle shall include delivery charges as outlined in the scope of work.

Authorized Signature: Ken Kunz Title: CFO

Print/Type Name: Ken Kunz Phone: 314-755-1212

E-mail: Manuel.G@Anovafurnishings.com Fax: 314-755-1213

Firm Name: Anova Furnishings F.E.I.N. No: 43-0957292

Address: 211 N. Lindbergh Blvd City: St Louis 64131 State: MO

THE EXECUTION OF THIS FORM CONSTITUTES THE UNEQUIVOCAL OFFER OF THE BIDDER TO BE BOUND BY THE TERMS OF ITS BID. FAILURE TO SIGN THIS BID PRICE FORM WHERE INDICATED ABOVE BY AN AUTHORIZED REPRESENTATIVE OR PROVIDE THE FORM AS PRESENTED MAY RENDER THE BIDDER NON-RESPONSIVE

**BIDDER'S AFFIDAVIT**

**SOLICITATION:** IFB No. 2019-033 – Trash and Recycling Receptacles

**SUBMITTED TO:** City of Coral Gables  
Procurement Division  
2800 SW 72 Avenue  
Miami, Florida 33155

The undersigned acknowledges and understands the information contained in response to this solicitation and the referenced Schedules A through H shall be relied upon by Owner awarding the contract and such information is warranted by the Bidder to be true and correct. The discovery of any omission or misstatements that materially affects the Bidder's ability to perform under the contract shall be cause for the City to reject the solicitation submittal, and if necessary, terminate the award and/or contract. I further certify that the undersigned name(s) and official signatures of those persons are authorized as (*Owner, Partner, Officer, Representative or Agent of the bidder that has submitted the attached response*). Schedules A through H are subject to Local, State and Federal laws (as applicable); both criminal and civil.

- SCHEDULE A – STATEMENT OF CERTIFICATION
- SCHEDULE B – NON-COLLUSION AND CONTINGENT FEE AFFIDAVIT
- SCHEDULE C – DRUG-FREE STATEMENT
- SCHEDULE D – BIDDER'S QUALIFICATION STATEMENT
- SCHEDULE E – CODE OF ETHICS, CONFLICT OF INTEREST, AND CODE OF SILENCE
- SCHEDULE F – AMERICANS WITH DISABILITIES ACT (ADA)
- SCHEDULE G – PUBLIC ENTITY CRIMES
- SCHEDULE H – ACKNOWLEDGEMENT OF ADDENDA

This affidavit is to be furnished to the City of Coral Gables with its solicitation response. It is to be filled in, executed by the bidder and notarized. If the response is made by a Corporation, then it should be executed by its Chief Officer. This document MUST be submitted with the solicitation response.

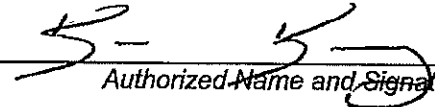
 Authorized Name and Signature	CFO Title	8/19/19 Date
--	--------------	-----------------

STATE OF Missouri  
COUNTY OF St. Louis

On this 20<sup>th</sup> day of August, 2019, before me the undersigned Notary Public of  
the State of Missouri, personally appeared Ken Kenz  
(Name(s) of individual(s) who appeared before Notary

And whose name(s) is/are subscribes to within the instrument(s), and acknowledges it's  
execution.

Wendy G. Curry  
NOTARY PUBLIC, STATE OF Missouri

Wendy G. Curry  
(Name of notary Public; Print, Stamp or  
Type as Commissioned.)

NOTARY PUBLIC  
SEAL OF OFFICE:

Personally know to me, or Produced  
Identification:

Personally known to me  
(Type of Identification Produced)

Wendy G Curry  
Notary Public - Notary Seal  
STATE OF MISSOURI  
Commissioned for St. Louis County  
My Commission Expires 6/11/2022  
I.D. # 18054914



**SCHEDULE "A" - CITY OF CORAL GABLES -- STATEMENT OF CERTIFICATION**

Neither I, nor the company, hereby represented has:

- a. employed or retained for a commission, percentage brokerage, contingent fee, or other consideration, any company or person (other than a bona fide employee working solely for me or the company) to solicit or secure this contract.
- b. agreed, as an express or implied condition for obtaining this contract, to employ or retain the services of any company or person in connection with carrying out the contract, or
- c. paid, or agreed to pay, to any company, organization or person (other than a bona fide employee working solely for me or the company) any fee, contribution, donation or consideration of any kind for, or in connection with, procuring or carrying out the contract except as here expressly stated (if any):

**SCHEDULE "B" - CITY OF CORAL GABLES - NON-COLLUSION AND CONTINGENT FEE AFFIDAVIT**

1. He/she is the   N/A    
*(Owner, Partner, Officer, Representative or Agent)*

of the bidder that has submitted the attached bid response.

- 2. He/she is fully informed with respect to the preparation and contents of the attached bid response and of all pertinent circumstances respecting such response;
- 3. Said response is made without any connection or common interest in the profits with any other persons making any response to this solicitation. Said response is on our part in all respects fair and without collusion or fraud. No head of any department, any employee or any officer of the City of Coral Gables is directly or indirectly interested therein. If any relatives of bidder's officers or employees are employed by the City, indicate name and relationship below.

Name:   N/A   Relationship:   N/A  

Name:   N/A   Relationship:   N/A  

- 4. No lobbyist or other bidder is to be paid on a contingent or percentage fee basis in connection with the award of this Contract.

**SCHEDULE "C" CITY OF CORAL GABLES – VENDOR DRUG-FREE STATEMENT**

Preference may be given to bidders submitting a certification with their bid/proposal certifying they have a drug- free workplace in accordance with Section 287.087, Florida Statutes. This requirement affects all public entities of the State and becomes effective January 1, 1991. The special condition is as follows:

1. Publish a statement notifying employees that the unlawful manufacture, distribution, dispensing, possession, or use of a controlled substance is prohibited in the workplace and specifying the actions that will be taken against employees for violations of such prohibition.
2. Inform employees about the dangers of drug abuse in the workplace, the business's policy of maintaining a drug-free workplace, any available drug counseling, rehabilitation, and employee assistance programs, and the penalties that may be imposed upon employees for drug abuse violations.
3. Give each employee engaged in providing the commodities or contractual services that are under solicitation a copy of the statement specified in subsection (1).
4. In the statement specified in subsection (1), notify the employees that, as a condition of working on the commodities or contractual services that are under solicitation, the employee will abide by the terms of the statement and will notify the employer of any conviction of, or plea of guilty or nolo contendere to, any violation of chapter 893 or of any controlled substance law of the United States or any state, for a violation occurring in the workplace no later than five (5) days after such conviction.
5. Impose a sanction on, or require the satisfactory participation in a drug abuse assistance or rehabilitation program if such is available in the employee's community, by any employee who is so convicted.
6. Make a good faith effort to continue to maintain a drug-free workplace through implementation of this section. As the person authorized to sign the statement, I certify that this form complies fully with the above requirements.

The company submitting this solicitation has established a Drug Free work place program in accordance with State Statute 287.087

**SCHEDULE "D" CITY OF CORAL GABLES – BIDDER'S QUALIFICATION STATEMENT**

The undersigned declares the truth and correctness of all statements and all answers to questions made hereinafter:

**GENERAL COMPANY INFORMATION:**

Company Name: Anova Furnishings

Address: 211 N. Lindbergh Blvd St Louis MO] 64131  
Street City State Zip Code

Telephone No: (314)755-1212 Fax No: (314)755-1213 Email: Manuel.G@anovafurnishings.com

How many years has your company been in business under its present name? 45 Years

If company is operating under Fictitious Name, submit evidence of compliance with Florida Fictitious Name Statute:

Under what former names has your company operated? : N/A

At what address was that company located? N/A

Is your Company Certified? Yes x No If Yes, ATTACH COPY of Certification.

Is your Company Licensed? Yes X No If Yes, ATTACH COPY of License

Has your company or its senior officers ever declared bankruptcy?  
Yes \_\_\_\_\_ No x If yes, explain: \_\_\_\_\_

**LEGAL INFORMATION:**

Please identify each incident *within the last five (5) years* where a civil, criminal, administrative, other similar proceeding was filed or is pending, if such proceeding arises from or is a dispute concerning the bidder's rights, remedies or duties under a contract for the same or similar type services to be provided under this solicitation **(A response is required. If applicable please indicate "none" or list specific information related to this question. Please be mindful that responses provided for this question will be independently verified)**:

N/A  
\_\_\_\_\_  
\_\_\_\_\_  
\_\_\_\_\_

Has your company ever been debarred or suspended from doing business with any government entity?

Yes \_\_\_\_\_ No x If Yes, explain \_\_\_\_\_

**SCHEDULE "E" CITY OF CORAL GABLES – CODE OF ETHICS, CONFLICT OF INTEREST, AND CONE OF SILENCE**

THESE SECTIONS OF THE CITY CODE CAN BE FOUND ON THE CITY'S WEBSITE, UNDER GOVERNMENT, CITY DEPARTMENT, PROCUREMENT, PROCUREMENT CODE (CITY CODE CHAPTER 2 ARTICLE VIII); SEC 2-1023; SEC 2-606; AND SEC 2-1027, RESPECTIVELY.

IT IS HEREBY ACKNOWLEDGED THAT THE ABOVE NOTED SECTIONS OF THE CITY OF CORAL GABLES CITY CODE ARE TO BE ADHERED TO PURSUANT TO THIS SOLICITATION.

**SCHEDULE "F" CITY OF CORAL GABLES - AMERICANS WITH DISABILITIES ACT (ADA) DISABILITY NONDISCRIMINATION STATEMENT**

I understand that the above named firm, corporation or organization is in compliance with and agreed to continue to comply with, and assure that any sub-contractor, or third party contractor under this project complies with all applicable requirements of the laws listed below including, but not limited to, those provisions pertaining to employment, provision of programs and service, transportation, communications, access to facilities, renovations, and new construction.

The American with Disabilities Act of 1990 (ADA), Pub. L. 101-336, 104 Stat 327, 42 U.S.C. 12101,12213 and 47 U.S.C. Sections 225 and 661 including Title I, Employment; Title 11, Public Services; Title III, Public Accommodations and Services Operated by Private Entities; Title IV, Telecommunications; and Title V, Miscellaneous Provisions.

The Florida Americans with Disabilities Accessibility Implementation Act of 1993, Sections 5553.501-553.513, Florida Statutes

The Rehabilitation Act of 1973, 229 U.S.C. Section 794

The Federal Transit Act, as amended, 49 U.S.C. Section 1612

The Fair Housing Act as amended, 42 U.S.C. Section 3601-3631

**SCHEDULE "G" CITY OF CORAL GABLES - STATEMENT PURSUANT TO SECTION 287.133 (3) (a), FLORIDA STATUTES, ON PUBLIC ENTITY CRIMES**

1. I understand that a "public entity crime" as define in Paragraph 287.133(1)(g), **Florida Statutes**, means a violation of any state or federal law by a person with respect to and directly related to the transaction of business with any public entity or with an agency or political subdivision of any other state or of the United States, including, but not limited to, any Proposal or contract for goods or services to be provided to any public entity or an agency or political subdivision of any other state or of the United States and involving antitrust, fraud, theft, bribery, collusion, racketeering, conspiracy, or material misrepresentation.
2. I understand that "convicted" or "conviction" as defined in Paragraph 287.133(1)(b), **Florida Statutes**, means a finding of guilt or a conviction of a public entity crime, with or without an adjudication of guilt, in any federal or state trial court of record relating to charges brought by indictment or information after July 1, 1989, as a result of a jury verdict, non-jury trial, or entry of a plea of guilty or nolo contendere.

3. I understand that an "affiliate" as defined in Paragraph 287.133(1)(a), Florida Statutes, means:
  1. A predecessor or successor of a person convicted of a public entity crime; or 2. An entity under the control of any natural person who is active in the management of the entity and who has been convicted of a public entity crime. The term "affiliate" includes those officers, directors, executives, partners, shareholders, employees, members, and agents who are active in the management of an affiliate. The ownership by one person of shares constituting a controlling interest in another person, or a pooling of equipment or income among persons when not for fair market value under an arm's length agreement, shall be a prima facie case that one person controls another person. A person who knowingly enters into a joint venture with a person who has been convicted of a public entity crime in Florida during the preceding 36 months shall be considered an affiliate.
4. I understand that a "person" as defined in Paragraph 287.133(1)(e), Florida Statutes, means any natural person or entity organized under the laws of any state or of the United States with the legal power to enter into a binding contract and which Proposals or applies to Proposal on contracts for the provision of goods or services let by a public entity, or which otherwise transacts or applies to transact business with a public entity. The term "person" includes those officers, directors, executives, partners, shareholders, employees, members, and agents who are active in management of an entity.
5. Based on information and belief, the statement which I have marked below is true in relation to the entity submitting this sworn statement. **[Must indicate which statement below applies.]**

Neither the entity submitting this sworn statement, nor any of its officers, directors, executives, partners, shareholders, employees, members, or agents who are active in the management of the entity, nor any affiliate of the entity has been charged with and convicted of a public entity crime subsequent to July 1, 1989.

The entity submitting this sworn statement, or one or more of its officers, directors, executives, partners, shareholders, employees, members, or agents who are active in the management of the entity, or an affiliate of the entity has been charged with and convicted of a public entity crime subsequent to July 1, 1989.

The entity submitting this sworn statement, or one or more of its officers, directors, executives, partners, shareholders, employees, members, or agents who are active in the management of the entity, or an affiliate of the entity has been charged with and convicted of a public entity crime subsequent to July 1, 1989. However, there has been subsequent proceeding before a Hearing Officer of the State of Florida, Division of Administrative Hearings and the Final Order entered by the Hearing Officer determined that it was not in the public interest to place the entity submitting this sworn statement on the convicted vendor list.

**[Attach a copy of the final order]**

**I UNDERSTAND THAT THE SUBMISSION OF THIS FORM TO THE CONTRACTING OFFICER FOR THE PUBLIC ENTITY IS FOR THAT PUBLIC ENTITY ONLY AND, THAT THIS FORM IS VALID THROUGH DECEMBER 31 OF THE CALENDAR YEAR IN WHICH IT IS FILED. I ALSO UNDERSTAND THAT I AM REQUIRED TO INFORM THE PUBLIC ENTITY PRIOR TO ENTERING INTO A CONTRACT IN EXCESS OF THE THRESHOLD AMOUNT PROVIDED IN SECTION 287.017, FLORIDA STATUTES FOR CATEGORY TWO OF ANY CHANGE IN THE INFORMATION CONTAINED IN THIS FORM.**

**SCHEDULE "H" CITY OF CORAL GABLES - ACKNOWLEDGEMENT OF ADDENDA**

1. The undersigned agrees, if this bid response is accepted, to enter in a Contract with the CITY to perform and furnish all work as specified or indicated in the solicitation, any associated addendum and Contract Documents within the contract time indicated in the solicitation and in accordance with the other terms and conditions of the solicitation and contract documents.
2. Acknowledgement is hereby made of the following Addenda, if any (identified by number) received since issuance of the applicable solicitation.

Addendum No 1 Date 08/09/2019

Addendum No. 4 Date 8/30/19

Addendum No 2 Date 8/21/19

Addendum No. \_\_\_\_\_ Date \_\_\_\_\_

Addendum No 3 Date 8/30/19

Addendum No. \_\_\_\_\_ Date \_\_\_\_\_

**Failure to adhere to changes communicated via any addendum may render your response non-responsive.**