

**CITY OF CORAL GABLES, FLORIDA**

**RESOLUTION NO. 2019-21**

A RESOLUTION APPROVING ACQUISITION OF TWENTY-TWO (22) SPEECH BUBBLE ARTWORK SIGNS FROM "***THE TRUTH IS I WELCOME YOU***" BY HANK WILLIS THOMAS AND INSTALLATION ON MIRACLE MILE OF THE ARTWORK "ERNEST AND RUTH" BY HANK WILLIS THOMAS. (UNANIMOUSLY RECOMMENDED BY THE CULTURAL DEVELOPMENT BOARD APPROVAL/DENIAL VOTE: 4 TO 0).

**WHEREAS**, the Cultural Development Board recommends items of artistic and cultural significance to the City Commission; and

**WHEREAS**, a proposal was received by the City for the acquisition of the twenty-two speech bubble artwork signs currently installed from "***The Truth Is I Welcome You***" exhibition by Hank Willis Thomas; and

**WHEREAS**, the Cultural Development Board unanimously (4-0) passed a motion to recommend to the Coral Gables City Commission acquisition of the artworks; and

**WHEREAS**, the Cultural Development Board included in their motion a recommendation to permanently install the artwork *Ernest and Ruth* by Hank Willis Thomas on Miracle Mile; and

**WHEREAS**, funding for the acquisition and installation is being proposed through art acquisition funds previously set aside for public art on Miracle Mile with the cost of annual maintenance proposed through use of the general fund as ordinary maintenance;

**NOW, THEREFORE, BE IT RESOLVED BY THE COMMISSION OF THE CITY OF CORAL GABLES AS FOLLOWS:**

**SECTION 1.** That the foregoing "Whereas" clauses are here hereby ratified and confirmed as being true and correct and are hereby made a specific part of this Resolution upon the adoption hereof.

**SECTION 2.** The City Commission does hereby authorize the acquisition of twenty-two speech bubble artwork signs currently installed from "***The Truth Is I Welcome You***" exhibition by Hank Willis Thomas; authorize installation of *Ernest and Ruth* within the Miracle Mile Streetscape; allows for \$200,000 plus installation costs from the Art Acquisition Fund currently dedicated to public art on Miracle Mile; and allows annual maintenance from the General Fund.

**SECTION 3.** That this resolution shall become effective upon the date of its passage and adoption herein.

PASSED AND ADOPTED THIS TWENTY-SECOND DAY OF JANUARY, A.D.,  
2019.

(Moved: Mena / Seconded: Quesada)  
(Unanimous: Mena, Quesada, Keon, Lago, Valdes-Fauli)  
(Unanimous: 5-0 Vote)  
(Agenda Item: 2-1)

APPROVED:

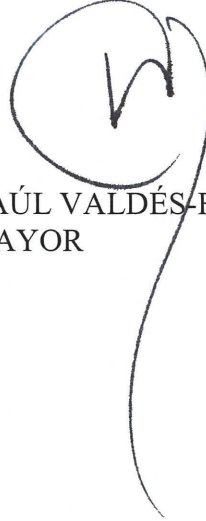
A handwritten signature in black ink, consisting of a large, stylized letter 'R' that loops around and ends in a long, thin tail extending downwards.

RAÚL VALDÉS-FAULI  
MAYOR

ATTEST:

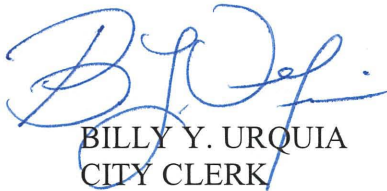
A handwritten signature in blue ink, appearing to read 'B. Y. Urquia' with a stylized flourish at the end.

BILLY Y. URQUIA  
CITY CLERK

APPROVED AS TO FORM  
AND LEGAL SUFFICIENCY:

A handwritten signature in blue ink, consisting of several loops and a long vertical stroke.

MIRIAM SOLER RAMOS  
CITY ATTORNEY

## HANK WILLIS THOMAS – BIOGRAPHY

Hank Willis Thomas is a conceptual artist working primarily with themes related to identity, history and popular culture. His work has been exhibited throughout the U.S. and abroad including, the International Center of Photography, Guggenheim Museum Bilbao, Musée du quai Branly, and the Cleveland Museum of Art. Thomas' work is in numerous public collections including the Museum of Modern Art New York, the Solomon R. Guggenheim Museum, the Whitney Museum of American Art, the Brooklyn Museum, the High Museum of Art and the National Gallery of Art in Washington DC, among others. His collaborative projects include Question Bridge: Black Males, In Search Of The Truth (The Truth Booth), and For Freedoms. For Freedoms was awarded the 2017 ICP Infinity Award for New Media and Online Platform. Thomas is also the recipient of the 2017 Soros Equality Fellowship and the 2017 AIMIA | AGO Photography Prize. In 2017, Thomas unveiled his permanent public artwork "Love Over Rules" in San Francisco and "All Power to All People" in Opa Locka, Florida. Thomas is a member of the Public Design Commission for the City of New York. He received a BFA in Photography and Africana studies from New York University and a MFA/MA in Photography and Visual Criticism from the California College of Arts. He has also received honorary doctorates from the Maryland Institute of Art and the Institute for Doctoral Studies in the Visual Arts. Thomas lives and works in New York City.

## Coral Gables December 2018 Proposal

### Hank Willis Thomas

Hank Willis Thomas continued exploration of identity, history and popular culture will be visualized in Coral Gables in two ways: by using large 3-dimensional speech bubbles installed on posts throughout Miracle Mile, and speech bubble-inspired bench designs in diverse sites throughout the villages of Coral Gables. The culmination of this 2-part installation will invite us to approach our different perspectives on truth with a new sense of understanding.

Each hanging speech bubble sign will contain a line from the poem *the truth is i am you* written by Hank Willis Thomas and Ryan Alexiev translated into the most spoken languages in Coral Gables. The phrases of the poem feature universal statements about the human condition and the translations communicate the essence of each English statement, as opposed to a direct translation.

The benches will seek to enhance public space as a portal to consider who we are, what we value, where we come from, and where we are going as a diverse group of people sharing the same space and social goals. In Coral Gables, the installation will explore the nature of truth and understanding across cultures by drawing upon the area's distinct architectural villages, including the Chinese, French, Dutch South African, and McFarland Homestead, to name a few. This interactive installation will act as a connector by offering a collective space of contemplation.

Pedestrians become part of the piece by walking through the sign populated areas or sitting in the benches. The installation provides a moment of pause in the fast pace lives of community members who will have an opportunity to reflect on the abundance of ways an idea can be common to all and expressed, as well as communicated, to a wide range of people. Made of bright colors and rolled steel, the benches will create spaces not just to reflect upon the vibrancy of the surrounding environment, but also to provide a place of introspection.

# Speech Bubble Signs currently installed on Miracle Mile

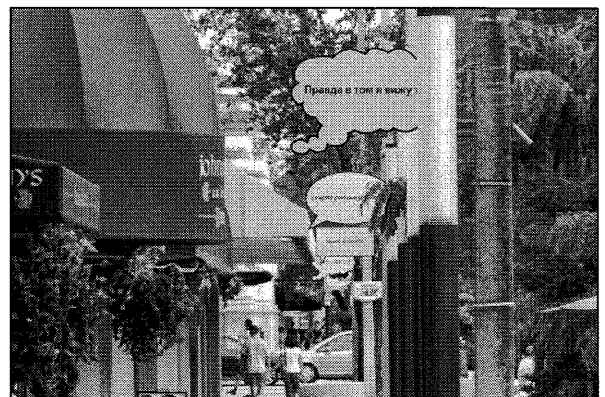
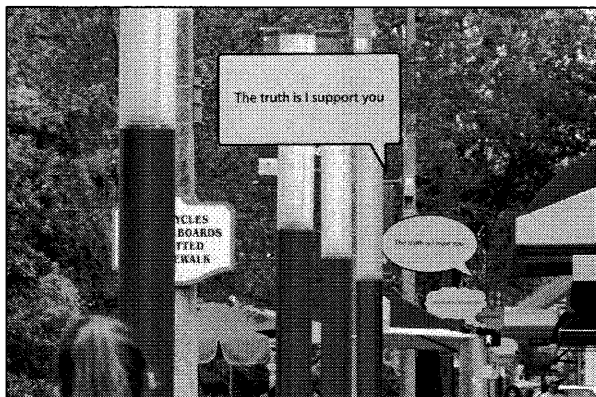

## Speech Bubble Signs

Previous Installation Examples:

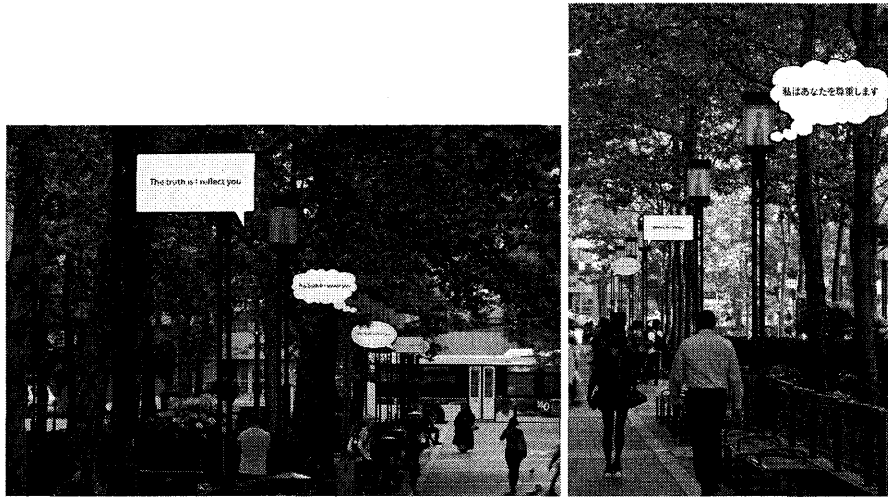

“The Truth Is...” 2015, Installation at MetroTech Commons, Brooklyn, NY

Proposed Location:

Miracle Mile



The Miracle Mile light poles pose an ideal location for “the truth is i am you” hanging signs. Visitors will be welcomed into the heart of Coral Gables with messages of truths in the most spoken languages of the community. The work is activated by pedestrians who appear as if they are issuing the phrases themselves, either by intentionally standing underneath them or by appearing underneath them to the perspective of other viewers.

the truth is i am you

written by Hank Willis Thomas and Ryan Alexiev

the truth is i love you

the truth is i know you

the truth is i see you

the truth is i hear you

the truth is i fear you

the truth is i feel you

the truth is i believe you

the truth is i become you

the truth is i judge you

the truth is i respect you

the truth is i remember you



the truth is i remind you





the truth is i am you

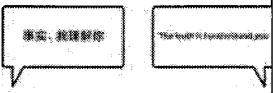











**“The Truth is I Welcome You” WORKS PRODUCED**



	<b>Artwork Image</b>	<b>Description of Work</b>	<b>Retail Sale Price</b>	<b>To Be Paid by Coral Gables for Acquisition</b>	<b>Agreed Upon Special Set Acquisition Price</b>
1.		<i>The truth is I am you: The truth is I love you (Arabic), 2015</i> aluminum lamppost sign with vinyl graphics on both sides 36 x 36 x 1 1/2 inches Unique HWT15.123	\$12,000	\$10,870	
2.		<i>The truth is I am you: The truth is I understand you (Chinese), 2015</i> aluminum lamppost sign with vinyl graphics on both sides 36 x 36 x 1 1/2 inches Unique HWT15.124	\$12,000	\$10,870	
3.		<i>The truth is I am you: The truth is I trust you (Croatian), 2015</i> aluminum lamppost sign with vinyl graphics on both sides 36 x 36 x 1 1/2 inches Unique HWT15.125	\$12,000	\$10,870	

4.		<p><i>The truth is I am you: The truth is I hear you (French), 2015</i> aluminum lamppost sign with vinyl graphics on both sides 36 x 36 x 1 1/2 inches Unique HWT15.126</p>	\$12,000	\$10,870	
5.		<p><i>The truth is I am you: The truth is I remind you (French Creole), 2015</i> aluminum lamppost sign with vinyl graphics on both sides 36 x 36 x 1 1/2 inches Unique HWT15.127</p>	\$12,000	\$10,870	
6.		<p><i>The truth is I am you: The truth is I need you (German), 2015</i> aluminum lamppost sign with vinyl graphics on both sides 36 x 36 x 1 1/2 inches Unique HWT15.128</p>	\$12,000	\$10,870	
7.		<p><i>The truth is I am you: The truth is I accept you (Greek), 2015</i> aluminum lamppost sign with vinyl graphics on both sides 36 x 36 x 1 1/2 inches Unique HWT15.129</p>	\$12,000	\$10,870	

8.		<p><i>The truth is I am you: The truth is I am you (Hebrew), 2015</i> aluminum lamppost sign with vinyl graphics on both sides 36 x 36 x 1 1/2 inches Unique HWT15.130</p>	\$12,000	\$10,870	
9.		<p><i>The truth is I am you: The truth is I follow you (Hindi), 2015</i> aluminum lamppost sign with vinyl graphics on both sides 36 x 36 x 1 1/2 inches Unique HWT15.131</p>	\$12,000	\$10,870	
10.		<p><i>The truth is I am you: The truth is I believe you (Hungarian), 2015</i> aluminum lamppost sign with vinyl graphics on both sides 36 x 36 x 1 1/2 inches Unique HWT15.132</p>	\$12,000	\$10,870	
11.		<p><i>The truth is I am you: The truth is I reflect you (Italian), 2015</i> aluminum lamppost sign with vinyl graphics on both sides 36 x 36 x 1 1/2 inches Unique HWT15.133</p>	\$12,000	\$10,870	

12.		<p><i>The truth is I am you: The truth is I respect you (Japanese), 2015</i> aluminum lamppost sign with vinyl graphics on both sides 36 x 36 x 1 1/2 inches Unique HWT15.134</p>	\$12,000	\$10,870	
13.		<p><i>The truth is I am you: The truth is I remember you (Korean), 2015</i> aluminum lamppost sign with vinyl graphics on both sides 36 x 36 x 1 1/2 inches Unique HWT15.135</p>	\$12,000	\$10,870	
14.		<p><i>The truth is I am you: The truth is I balance you (Polish), 2015</i> aluminum lamppost sign with vinyl graphics on both sides 36 x 36 x 1 1/2 inches Unique HWT15.136</p>	\$12,000	\$10,870	
15.		<p><i>The truth is I am you: The truth is I support you (Portuguese), 2015</i> aluminum lamppost sign with vinyl graphics on both sides 36 x 36 x 1 1/2 inches Unique HWT15.137</p>	\$12,000	\$10,870	

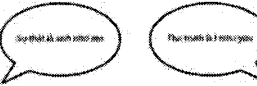
16.		<p><i>The truth is I am you: The truth is I see you (Russian), 2015</i> aluminum lamppost sign with vinyl graphics on both sides 36 x 36 x 1 1/2 inches Unique HWT15.138</p>	\$12,000	\$10,870	
17.		<p><i>The truth is I am you: The truth is I choose you (Spanish), 2015</i> aluminum lamppost sign with vinyl graphics on both sides 36 x 36 x 1 1/2 inches Unique HWT15.139</p>	\$12,000	\$10,870	
18.		<p><i>The truth is I am you: The truth is I feel you (Swahili), 2015</i> aluminum lamppost sign with vinyl graphics on both sides 36 x 36 x 1 1/2 inches Unique HWT15.140</p>	\$12,000	\$10,870	
19.		<p><i>The truth is I am you: The truth is I liberate you (Tagalog), 2015</i> aluminum lamppost sign with vinyl graphics on both sides 36 x 36 x 1 1/2 inches Unique HWT15.141</p>	\$12,000	\$10,870	

20.		<p><i>The truth is I am you: The truth is I know you (Urdu),</i> 2015 aluminum lamppost sign with vinyl graphics on both sides 36 x 36 x 1 1/2 inches Unique HWT15.142</p>	\$12,000	\$10,870	
21.		<p><i>The truth is I am you: The truth is I miss you (Vietnamese),</i> 2015 aluminum lamppost sign with vinyl graphics on both sides 36 x 36 x 1 1/2 inches Unique HWT15.143</p>	\$12,000	\$10,870	
22		<p><i>The truth is I am you: The truth is I welcome you (Yiddish),</i> 2015 aluminum lamppost sign with vinyl graphics on both sides 36 x 36 x 1 1/2 inches Unique HWT15.144</p>	\$12,000	\$10,870	
<b>Total</b>			<b>\$264,000</b>	<b>\$239,140</b>	<b>\$200,000</b>

SONGHA  
& COMPANY · LLC

63 Flushing Ave. Unit 220 Brooklyn, NY 11206



Installed at MetroTech Commons  
Brooklyn, NY

Installed on Miracle Mile  
Coral Gables, FL

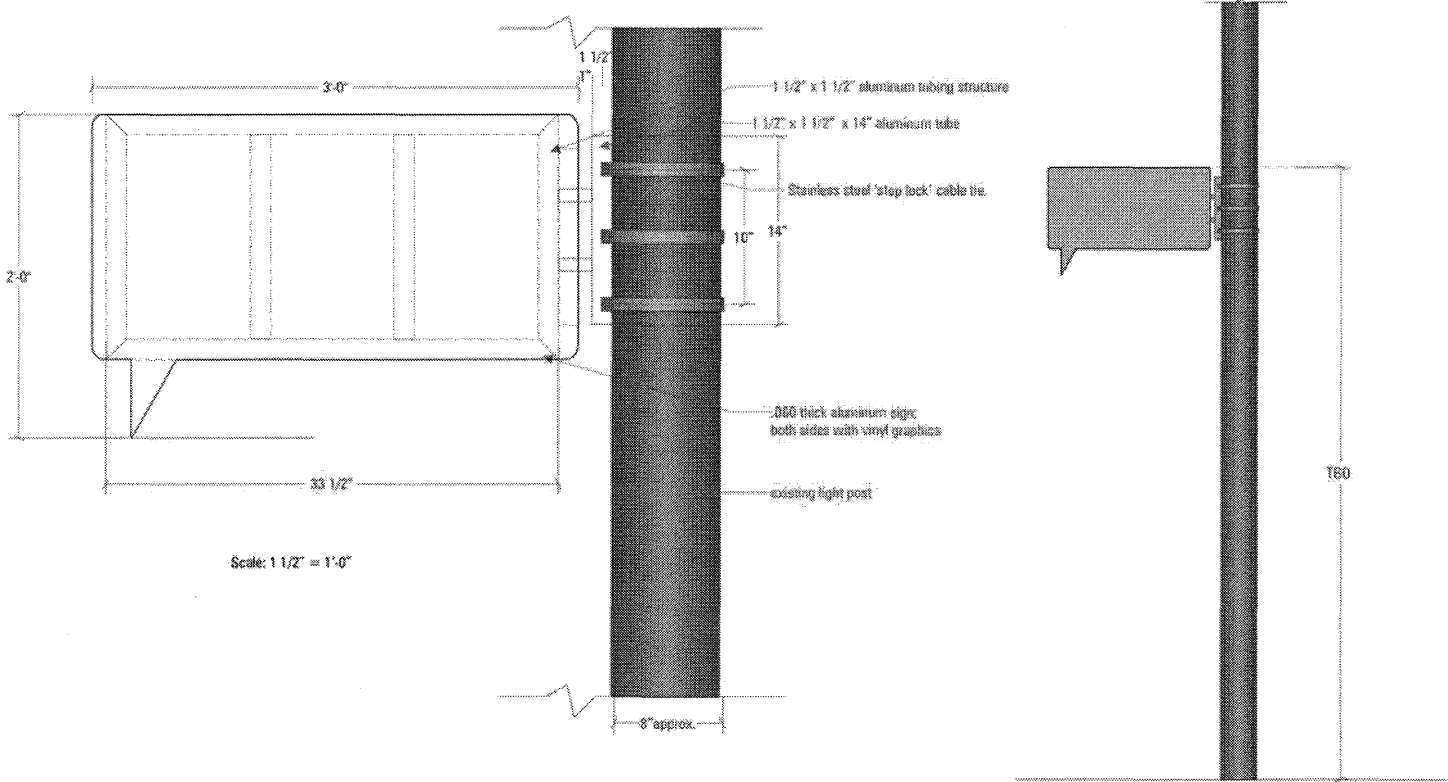

**INSTALLATION DIAGRAMS**



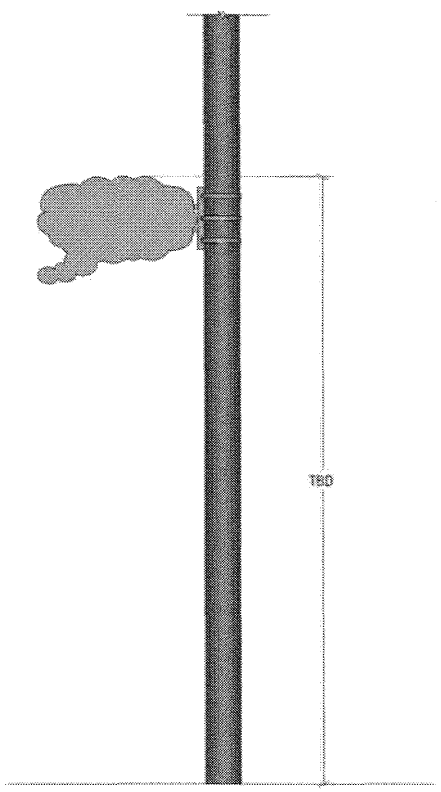
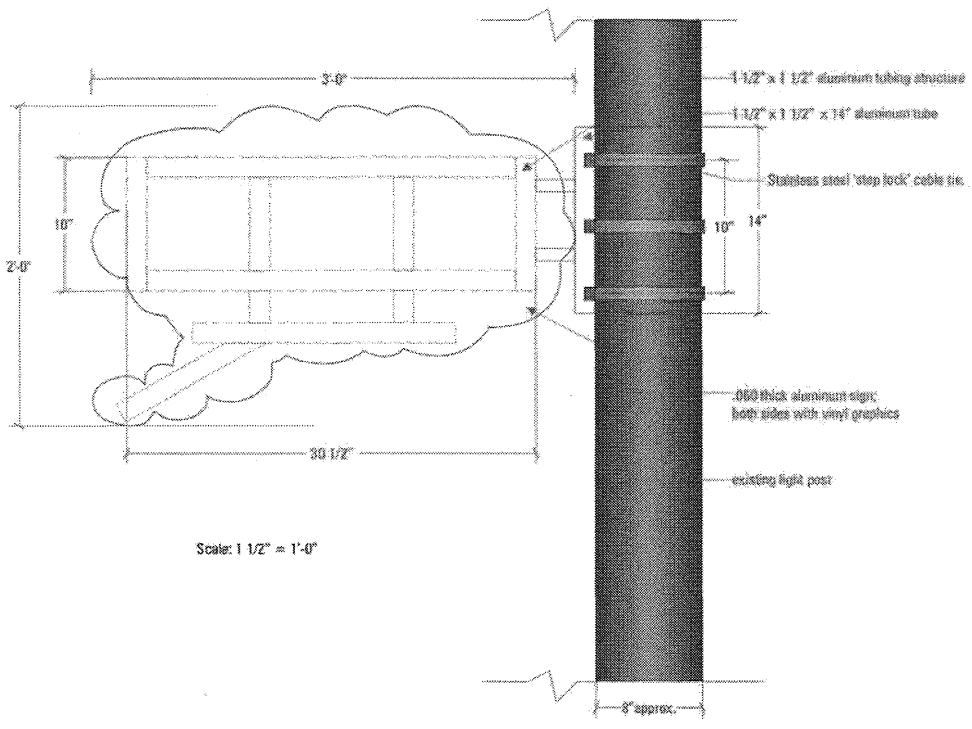

**INSTALLATION DIAGRAMS**

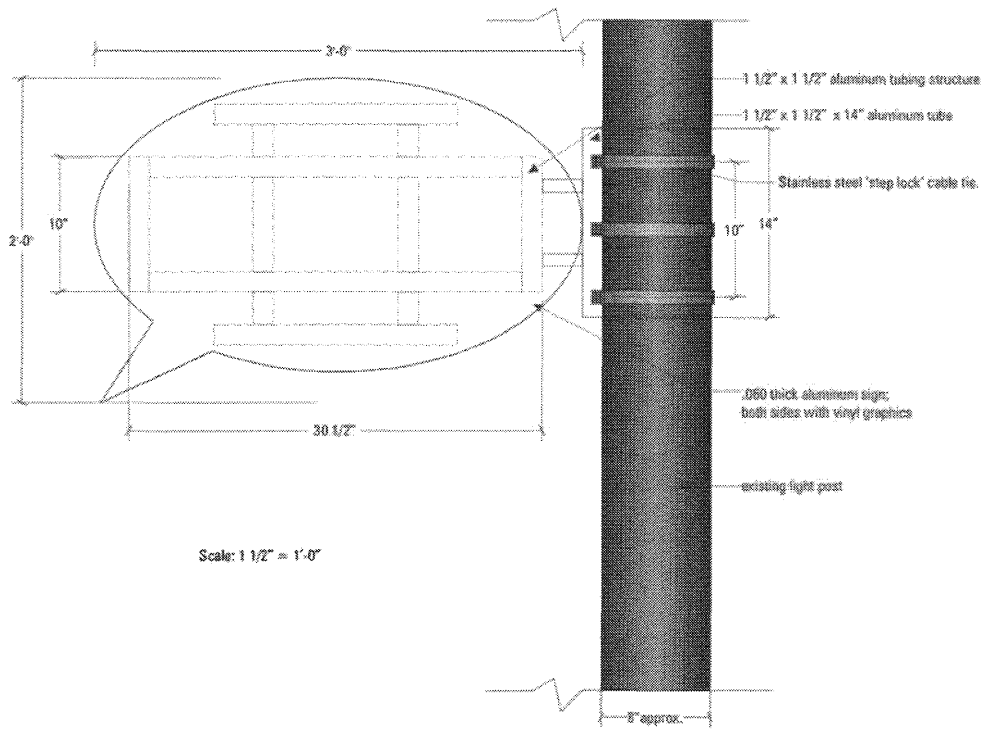

Scale: 1 1/2" = 1'-0"

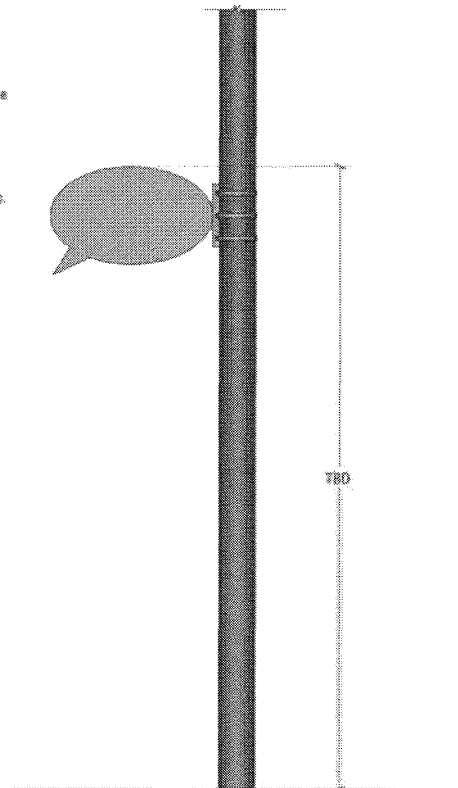

Scale: 1/2" = 1'-0"

**INSTALLATION DIAGRAMS**

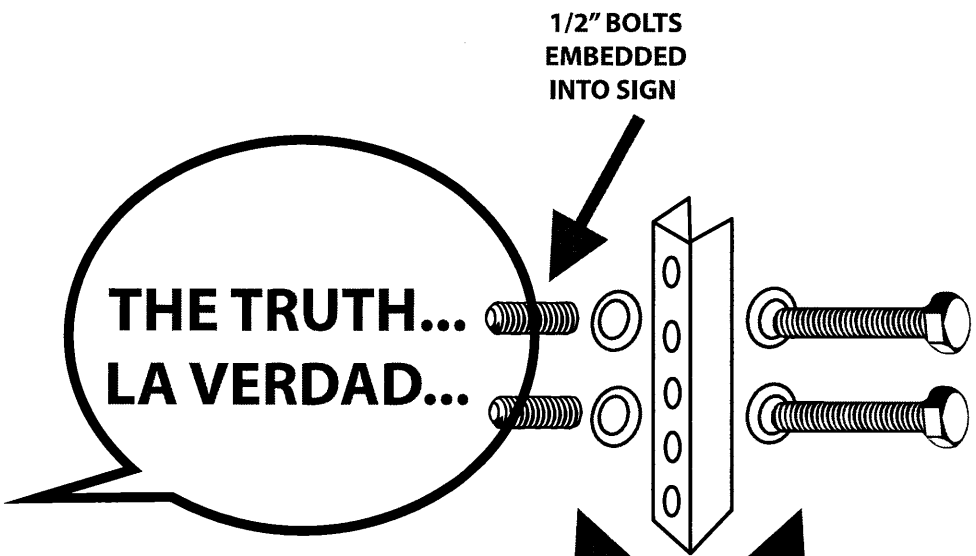

1/2" BOLTS  
EMBEDDED  
INTO SIGN

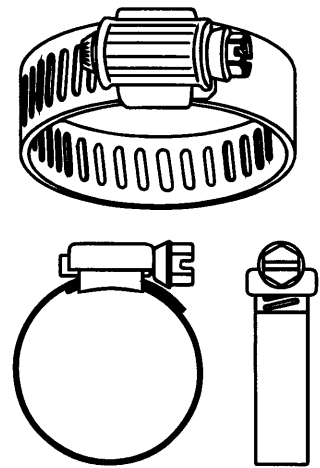

1/2" STAINLESS STEEL  
STRAPS WITH  
WORM SCREWS

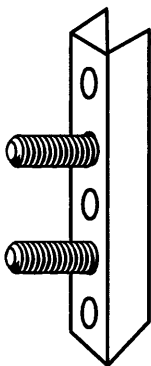

1/2" WASHERS  
AND BOLTS  
STAINLESS STEEL

INSTALLED < (2) TOP (2) BOTTOM > ON BRACKET TO POLE

**INSTALLATION DIAGRAMS**