

**CITY OF CORAL GABLES**

**- MEMORANDUM -**

**TO:** ARCELI REDILA  
PRINCIPAL PLANNER

**DATE:** February 3, 2022

**FROM:** CHERIE RODRIGUEZ, P.E.  
TRANSPORTATION ENGINEER

**SUBJECT:** Alexan Craft Development

---

**Proposed Development:** Alexan Craft Development – Residential Building  
**Contents of Development:** 7-story building with multi-family residential (283 units)  
**Proposed Location:** 330 Catalonia Avenue, Coral Gables, Florida

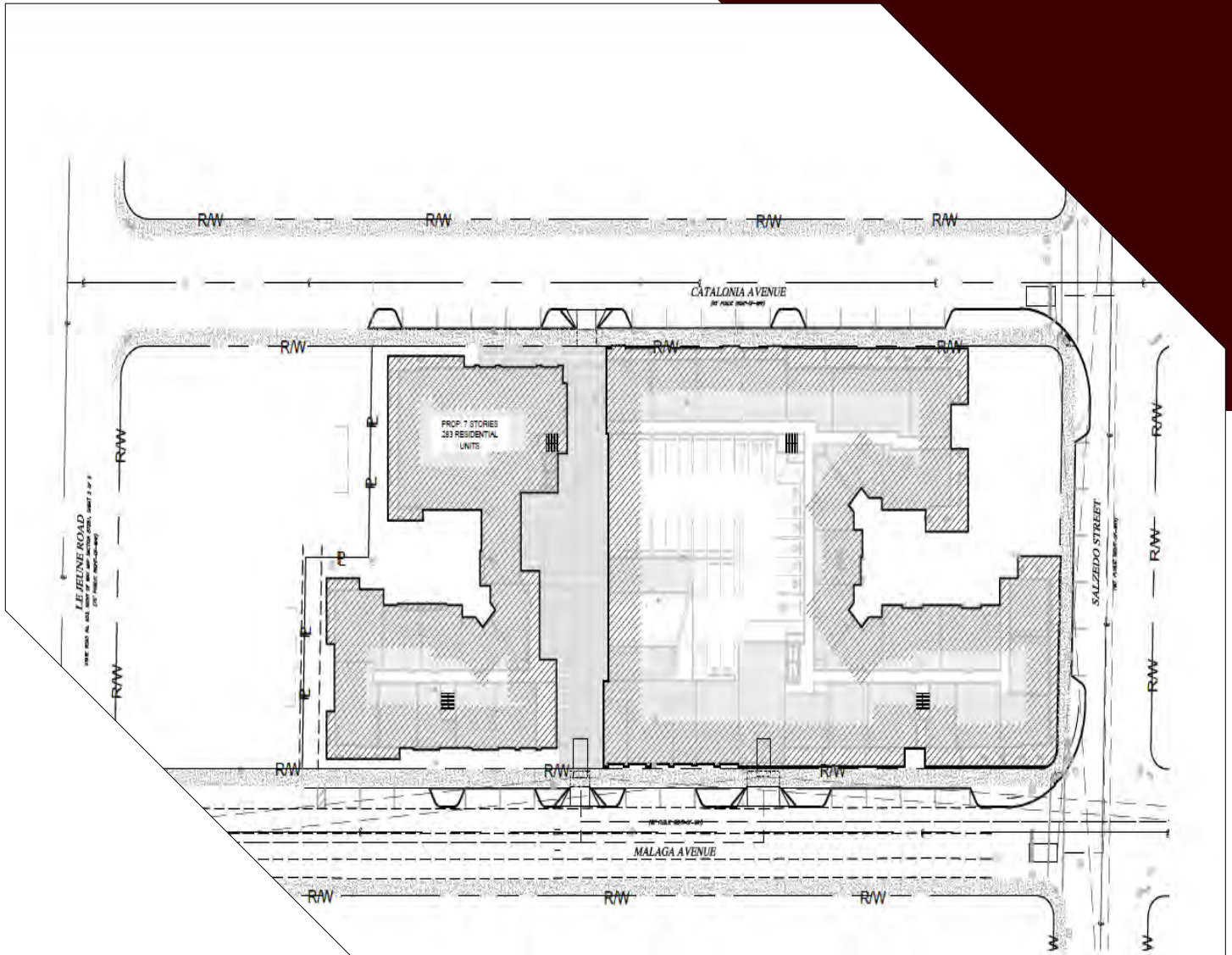
---

**Resolution**

The City of Coral Gables Public Works Department reviewed the information, comments provided by the consultants, and revised traffic study. Based on the City's review, the traffic study for the proposed development at 330 Catalonia Avenue meets the requirements stated within City of Coral Gables *Ordinance 2018-09* and applicable TIS Standards.

Based on the traffic study's findings, the traffic impacts associated to the proposed development of Alexan Craft concluded that most of the intersections will maintain conditions that are similar to the baseline conditions presented in future no-build conditions. As a result, the proposed development of Alexan Craft is not expected to have a negative impact in the surrounding roadway network.

Should there be any changes or questions, please contact the Project Manager, Cherie Rodriguez at [crodriguez3@coralgables.com](mailto:crodriguez3@coralgables.com).



# Alexan Craft Development

*Traffic Impact Study*

City of Coral Gables,  
Miami-Dade County

September 2021



## ENGINEER'S CERTIFICATION

I, Juan S. Calderon, certify that I currently hold an active Professional Engineer's License in the State of Florida and I am competent through education and experience to provide engineering services in the civil and traffic engineering disciplines contained in this report. I further certify that this report was prepared by me, or under my responsible charge, as required by Chapter 61G15-18. F.A.C. and that all statements, conclusions and recommendations made herein are true and correct to the best of my knowledge and ability.

**Project:** Alexan Craft Development  
**Location:** Miami-Dade County, Florida  
**Client:** Melissa Mojarena De Zayas, P.E.  
Department of Public Works  
**Report Prepared by:** CALTRAN Engineering Group, Inc.  
790 NW 107<sup>th</sup> Avenue Suite 200  
Miami, FL 33172  
Certificate of Authorization 29379

I acknowledge that the procedures and references used to develop the results contained in this report are standards to the professional practice of transportation engineering as applied through professional judgement and experience.

THIS ITEM HAS BEEN DIGITALLY SIGNED  
AND SEALED BY

ON THE DATE ADJACENT TO THE SEAL

PRINTED COPIES OF THIS DOCUMENT ARE  
NOT CONSIDERED SIGNED AND SEALED  
AND THE SIGNATURE MUST BE VERIFIED  
ON ANY ELECTRONIC COPIES.

CALTRAN ENGINEERING GROUP  
790 NW 107 AVENUE, Suite 200  
MIAMI, FL 33172  
CERTIFICATE OF AUTHORIZATION 29379  
JUAN S. CALDERON, P.E. NO. 58569

## TABLE OF CONTENTS

1.0	Executive Summary.....	5
2.0	Analysis Methodology.....	8
3.0	Background .....	10
4.0	Field Review.....	12
5.0	Scenario 1 – Existing Conditions.....	13
5.1	Existing Geometric Conditions .....	13
5.2	Key Intersections.....	14
5.3	Traffic Data Collection.....	14
5.3.1	Daily Traffic Volumes.....	14
5.3.2	Turning Movement Counts (TMC’s).....	16
6.0	Scenario 2 – Future Conditions No Build-Out and Growth Analysis .....	19
6.1	Historical Traffic Data.....	19
6.1.1	Historical Traffic Growth Rate Analysis.....	20
6.2	SERPM 8.0 Model Traffic Data .....	21
6.2.1	Model Growth Rate Analysis .....	22
6.3	Growth Rate Determination.....	22
6.4	Committed Developments and Work Program Projects .....	23
7.0	Scenario 3 – Future Conditions: Proposed Residential Development Build-Out Condition .....	25
7.1	Proposed Development Trip Generation .....	25
7.2	Cardinal Trip Distribution (TAZ 1077).....	26
8.0	Level of Service Analysis.....	31
8.1	Mitigation Measures .....	33
9.0	Turn Lane Evaluation .....	35
10.0	Concurrency Analysis.....	36
11.0	Preliminary Signal Warrant.....	37
11.1	Warrant 2, Four-Hour Vehicular Volume:.....	37
11.2	Warrant 7, Crash Experience .....	38
11.3	Final Preliminary Signal Warrant Determination.....	39
12.0	Conclusions and Recommendations .....	40

## **TABLE OF FIGURES**

Figure 1: Project Location Map .....	11
Figure 2: Daily Average Volumes .....	17
Figure 3: Peak Hour Turning Movement Counts .....	18
Figure 4: Traffic Monitoring Sites .....	20
Figure 5: Peak Hour Future No-Build Condition Traffic Volumes (Scenario 2).....	24
Figure 6: Peak Hour Development Trip Distribution (Egress).....	27
Figure 7: Peak Hour Development Trip Distribution (Ingress).....	28
Figure 8: Development Ingress/Egress Trip Distribution .....	29
Figure 9: Future Build-Out Condition Peak Traffic Volumes (Scenario 3) .....	30

## **LIST OF TABLES**

Table 1: Existing and Proposed Land Use Codes .....	10
Table 2: Roadway Segments Configuration .....	13
Table 3: Daily Peak Hour Traffic Volume .....	15
Table 4: Historical AADT .....	19
Table 5: Historical Growth Analysis Result.....	21
Table 6: SERPM 8.0 Volume Outputs .....	21
Table 7: Model Growth Analysis Results.....	22
Table 8: Net New Trip Generation for the Proposed Development .....	25
Table 9: Traffic Analysis Zones (TAZ 1077) .....	26
Table 10: Roadway Network Level of Service Analysis.....	32
Table 11: Analysis of Signal Retiming (AM/PM).....	33
Table 12: Storage Length Capacity (Synchro 95 <sup>th</sup> Percentile) Queues .....	35
Table 13: Concurrency Analysis LOS Results.....	36

## **LIST OF APPENDICES**

Appendix A. Development Site Plan

Appendix B. Data Collection / Field Pictures

Appendix C. Growth Factor Calculations

Appendix D. Trip Generation Letter

Appendix E. Trip Distribution / Traffic Analysis Zone

Appendix F. Synchro Reports and Related Information

Appendix G. FDOT QLOS Generalized Tables

Appendix H. Preliminary Signal Warrants

## **1.0 Executive Summary**

This study analyzes the traffic impact of the proposed Alexan Craft Development. This project encompasses a group of 283 multifamily residential units, in a parcel which currently contains 13 single family homes. Said proposed development will be bounded by Salcedo Street to the east, Lejeune Road to the west, Catalonia Avenue to the north, and Malaga Avenue to the south within the City of Coral Gables. The development site plans show proposed ingress and egress driveway points at Catalonia Avenue and Malaga Avenue, respectively.

As part of the Traffic Impact Study, CALTRAN has prepared the following:

- Existing geometric conditions and assessment of the impact area.
- Traffic data collection including Turning Movement Counts (TMC) at four (4) critical intersections and an additional two (2) locations obtained from a previous study.
- Evaluation of existing and future traffic operations; Level of Service, Concurrency Analysis.
- Traffic growth analysis including committed developments assessment.
- Provide a micro-simulation of existing and future conditions (year 2025) during AM and PM peak periods.
- A preliminary signal warrant at a critical intersection.
- Determine recommendations to mitigate possible impacts.

For the proposed development trip generation analysis contemplated the most conservative scenario of trip generation forecast rates. The trip generation analysis was performed under the following ITE land uses:

- 210 – Single-Family
- 221 - Multifamily Housing (Mid-Rise)

As part of the trip generation letter prepared by Kimley-Horn & Associates for this development it was concluded, that during the future build-out conditions (Scenario 3) the Alexan Craft development could generate about 1,272 net new daily trips and a maximum of 75 and 98 net new trips for the AM and PM peak period of the adjacent roadway, respectively. The final determinations of this analysis are presented as follows:

- The level of service (LOS) analysis concluded that the two main signalized intersections adjacent to the development are expected to maintain their current LOS in all three studied scenarios. The intersection of SR-953 / SW 42nd Avenue / Le Jeune Road at University Drive is expected to maintain current LOS F in both the AM and PM peak hours. Similarly, the intersection of Salzedo Street at University Drive will maintain current LOS B in the AM peak period and LOS C in the PM peak periods.
- The level of service (LOS) analysis concluded that the unsignalized intersections are expected to also maintain their current operational LOS. The intersection of Salzedo Street with Malaga Avenue will maintain LOS A during both the AM and PM peak periods. The intersection of Salzedo Street at Catalonia that is an All-Way Stop-Controlled intersection will be also maintaining current LOS A in both peak periods.
- The intersection of SR-953 / SW 42nd Avenue / Le Jeune Road at Malaga Avenue is expected to show increased delay in the AM peak period in the westbound direction, going from LOS E to LOS F in future build-out conditions (Scenario 3). The minor street approach also will experience an increase in delay during the PM peak period.
- There is another Two-Way Stop-Controlled intersection at SR-953 / SW 42nd Avenue / Le Jeune Road at Catalonia Avenue which is expected also to have a detrimental in LOS in the AM and PM as delay increase in the minor approach. It is worth noting that even though the delay appears to be high, the traffic volumes at these locations is very low (less than 50 vehicles in the peak period).



- As a mitigation measure, at the intersections of SR-953 / SW 42<sup>nd</sup> Avenue / Le Jeune Road and University Drive, it is recommended to perform signal re-timing in coordination with Miami-Dade County Traffic and Signal Division as a mitigation measure at the mentioned intersection.
- The turn lane evaluation analysis concluded that the signalized intersection of SR-953 / SW 42<sup>nd</sup> Avenue / Le Jeune Road at University Drive shows slight increases in queue accumulations in the northbound and eastbound left turn lanes. The eastbound left already exceeds the storage capacity of 225 feet with queues extending up to 525 feet under the existing condition (Scenario 1) to a maximum of 550 feet on future build-out conditions (Scenario 3). Thus, extending the eastbound left turn lane would require widening along University Drive which could bring impacts to mature trees. In the case of the northbound left queues which also are extending beyond the available storage distance in the PM peak period on all three scenarios, this movement is constrained due to a back-to-back storage bay for the southbound left into Sarto Avenue (south of University Drive).
- As part of this study, a preliminary signal warrant analysis was conducted using MUTCD Chapter 4C. This study was performed at the all-way stop-controlled intersection of Salzedo Street and Catalonia Avenue, and focused particularly on Warrants 2 and 7. The intersection did not meet any of the two examined warrant thresholds and is not expected to warrant a signal at this location.

Based on the findings, the traffic impacts associated to the proposed development of Alexan Craft concluded that most of the intersections will maintain conditions that are similar to the baseline conditions presented in future no-build conditions (Scenario 2).

As a result, the proposed development of Alexan Craft is not expected to have a negative impact in the surrounding roadway network.

## **2.0 Analysis Methodology**

The traffic impact analysis was performed in accordance to the Traffic Impact Study Methodologies developed by the City of Coral Gables. In addition, this study used guidance from the FDOT (Florida Department of Transportation) Traffic Impact Handbook; as well as, by following general guidelines from Miami-Dade County. This report includes field observations, data collection, and traffic operations analyzed using the capacity analysis methodology published in the Highway Capacity Manual (HCM) through Synchro 11 analysis software.

Three (3) development scenarios were analyzed as part of the traffic impact analysis on selected study area of influence.

- **Scenario 1 - Existing Conditions:** Current traffic was evaluated for a base condition establishment during a typical weekday peak hour from 7:00 AM to 9:00 AM and 4:00 PM to 6:00 PM time periods.
- **Scenario 2 - Future Conditions No Build-out Development Traffic:** Consistent with background traffic historical trends and/or the Southeast Regional Planning Model (SERPM), a growth rate was factored into the Existing Conditions (Scenario 1) analysis. As part of this Scenario 2 committed developments trips are included as applicable. This scenario will serve as the baseline to evaluate the impact of the new proposed development.
- **Scenario 3- Future Built-Out Condition Traffic:** The addition of the AM and PM peak hour trips expected to be generated by the proposed development to the forecasted volume obtained in Scenario-2 is analyzed as part of scenario 3.

For each of the three scenarios, a Level of Service (LOS) analysis is provided at the following intersections:

1. Salzedo Street at Malaga Avenue
2. Salzedo Street at University Drive
3. University Drive at SR-953/ SW 42nd Avenue / Le Jeune Road
4. SR-953/ SW 42nd Avenue / Le Jeune Road at Malaga Avenue
5. SR-953/ SW 42nd Avenue / Le Jeune Road at Catalonia Avenue
6. Salzedo Street at Catalonia Avenue

Considering the 95<sup>th</sup> percentile queues, a storage length analysis is to be performed for the critical movements affected by the additional forecasted trips within the network.

A preliminary signal warrant was also performed at the intersection of Salzedo Street and Catalonia Avenue due to its close proximity to the proposed development site and also as this particular intersection is an all-way stop controlled intersection under existing conditions. The warrants were performed following the Manual on Uniform Traffic Control Devices (MUTCD) Chapter 4C. The preliminary signal warrant focused on Warrants 2 and 7.

### 3.0 Background

CALTRAN Engineering Group, Inc. (CALTRAN) was retained by the City of Coral Gables to perform a traffic impact study for the proposed Alexan Craft development within the City. Said proposed development will be bounded by Salzedo Street to the east, LeJeune Road to the west, Catalonia Avenue to the north, and Malaga Avenue to the south.

This proposed development is to be a residential development composed of 283 multi-family units. The current site plans show ingress and egress driveway points at Catalonia Avenue and Malaga Avenue, respectively.

The proposed development intends to establish the following land uses summarized in **Table 1**.

**Table 1: Existing and Proposed Land Use Codes**

Land Use	Land Use Code	Variable
Single-Family (Existing)	210	Units
Multifamily Housing (Mid-Rise) (Proposed)	221	Units

A project location map illustrating the site of the proposed development is shown in **Figure 1** and Architectural Plans can be found in **Appendix A**.



**Figure 1: Project Location Map**

#### **4.0 Field Review**

A field review visit was performed on Tuesday September 21<sup>st</sup>, 2021 during regular PM peak period (4:30 PM - 5:30 PM). The objective of the field visit was to review the existing geometric conditions, review current traffic patterns and operations as well as to estimate and report potential roadway issues and identify opportunities for improvements. Pictures for the field visit can be found as part of **Appendix B**. The observations from the field visits are as follows:

- As the southbound lane at the intersection of Salzedo Street and University Drive is a shared left/right lane, high delays are observed when there is a vehicle that needs to turn left.
- Along University Drive at Salzedo Street in the eastbound and westbound directions, there is low traffic volumes during the PM peak hour with minor queue accumulations.
- The intersection of SR-953 / SW 42nd Avenue / Le Jeune Road and University presents long queues particularly in the westbound direction during the PM peak hour, long queues are the result of high volumes and on-street parking which has vehicles leaving affecting the shared through-right lane. The long queues usually clear within one signal cycle and no residual queues were observed once the westbound phase finishes.
- Very low pedestrian demands on the two signalized intersections of University Drive with Salzedo and with SR-953 / SW 42nd Avenue / Le Jeune Road. There is lack of push buttons in the intersection with Salzedo Street and no crosswalk is available in the east side of the intersection.
- The intersection of Catalonia at Salzedo Street is currently all-way stop-controlled. During the PM peak hour volumes are nominal and the longest queue accumulations observed only reached 3 vehicles in the southbound direction. Multiple vehicles stop slightly ahead of the stop bar.

## 5.0 Scenario 1 – Existing Conditions

Existing conditions evaluation includes an assessment of the current roadway geometry and traffic operations and general conditions during the weekday peak hours from 7:00 AM to 9:00 AM and 4:00 PM to 6:00 PM time periods within the study area.

### 5.1 Existing Geometric Conditions

A detailed field review was conducted to determine the existing intersection geometry, traffic control devices, signal phasing, and other factors which may affect intersection or roadway segment capacity.

Five (5) roadway segments were identified within the limits of the affected roadway network; existing geometric conditions are presented as follows:

- SR-953 / SW 42nd Avenue / LeJeune Road
- University Drive
- Salzedo Street
- Catalonia Avenue
- Malaga Avenue

**Table 2** summarizes the characteristics of each identified roadway segment.

**Table 2: Roadway Segments Configuration**

Segment	Posted Speed	Total Number of Lanes	Lane Width (feet)	Outside Shoulder	Median	Sidewalk
SR 953 / SW 42 <sup>nd</sup> Avenue / Le Jeune Road	40 mph	4 lanes	12 feet	Curb and Gutter	Painted / Turn Lanes	Both Sides
University Drive	30 mph	4 lanes	11 feet	Lawn	None	Both Sides
Salzedo Street	30 mph	2 lanes	12 feet	Curb	None	Both Sides
Catalonia Avenue	30 mph	2 lanes	21 feet*	Curb	None	Both Sides
Malaga Avenue	30 mph	2 lanes	21 feet*	Curb	None	Both Sides

Note (\*) Malaga Avenue and Catalonia Avenue allow for on-street parking. Lane width noted is half of the pavement surface width.

## 5.2 Key Intersections

Six (6) key intersections were selected for evaluation, their existing geometric conditions are as follows:

1. Salzedo Street at Malaga Avenue
2. Salzedo Street at University Drive
3. SR-953 / SW 42nd Avenue / Le Jeune Road at University Drive
4. SR-953 / SW 42nd Avenue / Le Jeune Road at Malaga Avenue
5. SR-953 / SW 42nd Avenue / Le Jeune Road at Catalonia Avenue
6. Salzedo Street at Catalonia Avenue

## 5.3 Traffic Data Collection

Consistent with the FDOT Data Collection standard methodologies, traffic data was collected within a typical weekday from Tuesday August 31<sup>st</sup>, 2021 to Thursday September 2<sup>nd</sup>, 2021. The data collection includes three 72-hour traffic volume stations and Turning Movement Counts (TMCs) for 4-hours collected on Tuesday of the same week.

### 5.3.1 Daily Traffic Volumes

**Table 3** presents Daily and Peak Hour Traffic Volumes (collected on August 31<sup>st</sup>, September 1<sup>st</sup> and 2<sup>nd</sup>, 2021) within the studied roadway network.



**Table 3: Daily Peak Hour Traffic Volume**

Day	Location	Direction	Volume	AM Peak Volume	PM Peak Volume
Tuesday Aug. 31st, 2021	Salzedo Street North of University Drive	Northbound	1,232	221	100
		Southbound	1,599	95	207
	LeJeune Rd North of University Drive	Northbound	14,835	1,245	1,084
		Southbound	16,190	1,138	1,328
	University Drive East of Le Jeune Road	Eastbound	2,315	375	205
		Westbound	3,416	157	533
Wednesday Sept. 1st, 2021	Salzedo Street North of University Drive	Northbound	1,346	191	103
		Southbound	1,600	96	213
	LeJeune Rd North of University Drive	Northbound	14,932	1,242	1,064
		Southbound	15,334	1,113	1,252
	University Drive East of Le Jeune Road	Eastbound	2,705	381	256
		Westbound	3,204	228	357
Thursday Sept. 2nd, 2021	Salzedo Street North of University Drive	Northbound	1,277	190	106
		Southbound	1,511	86	219
	LeJeune Rd North of University Drive	Northbound	14,586	1,220	1,087
		Southbound	15,861	1,143	1,414
	University Drive East of Le Jeune Road	Eastbound	2,725	406	237
		Westbound	3,278	171	433
Three-Day Average	Salzedo Street North of University Drive	Northbound	1,285	201	103
		Southbound	1,570	92	213
	LeJeune Rd North of University Drive	Northbound	14,784	1,236	1,078
		Southbound	15,795	1,131	1,331
	University Drive East of Le Jeune Road	Eastbound	2,582	387	233
		Westbound	3,299	185	441

### 5.3.2 Turning Movement Counts (TMC's)

Turning movement count data collection effort was performed at the following intersections:

- SR-953 / SW 42nd Avenue / Le Jeune Road at Malaga Avenue
- SR-953 / SW 42nd Avenue / Le Jeune Road at University Drive (Signalized)
- Salzedo Street at Malaga Avenue
- Salzedo Street at University Drive (Signalized)

In addition, data collection gathered from the Ponce Park Tower Traffic Impact Study were also used as part of this study. The data collection for that specific project occurred on October 14<sup>th</sup>, 2020 (Wednesday). The following are the locations collected as part of said study:

- SR-953 / SW 42nd Avenue / Le Jeune Road at Catalonia Avenue
- Salzedo Street at Catalonia Avenue

Since the data from these last two intersections was collected during the COVID-19 pandemic a factor was developed to adjust the traffic data to pre-pandemic conditions. The factor was developed from the volumes reported by FDOT count stations 87-0024 and 87-8410, upon a comparison between 2019 and 2020 volumes. The factor was determined to be an average of 1.23 in reference to both sites, in order to maintain consistency with the nearby committed development. This value is obtained from the Ponce Park Tower Traffic Impact Study that ultimately was completed in November, 2020.

The 3-day average of the 72-hr volume counts as well as existing turning movement counts are illustrated in **Figures 2 and 3**. All of the traffic volumes shown in these two figures include the applicable factors (Peak Hour Factor, SF, and COVID-19 factor as applicable).

Raw data collection information can be found in **Appendix B**.

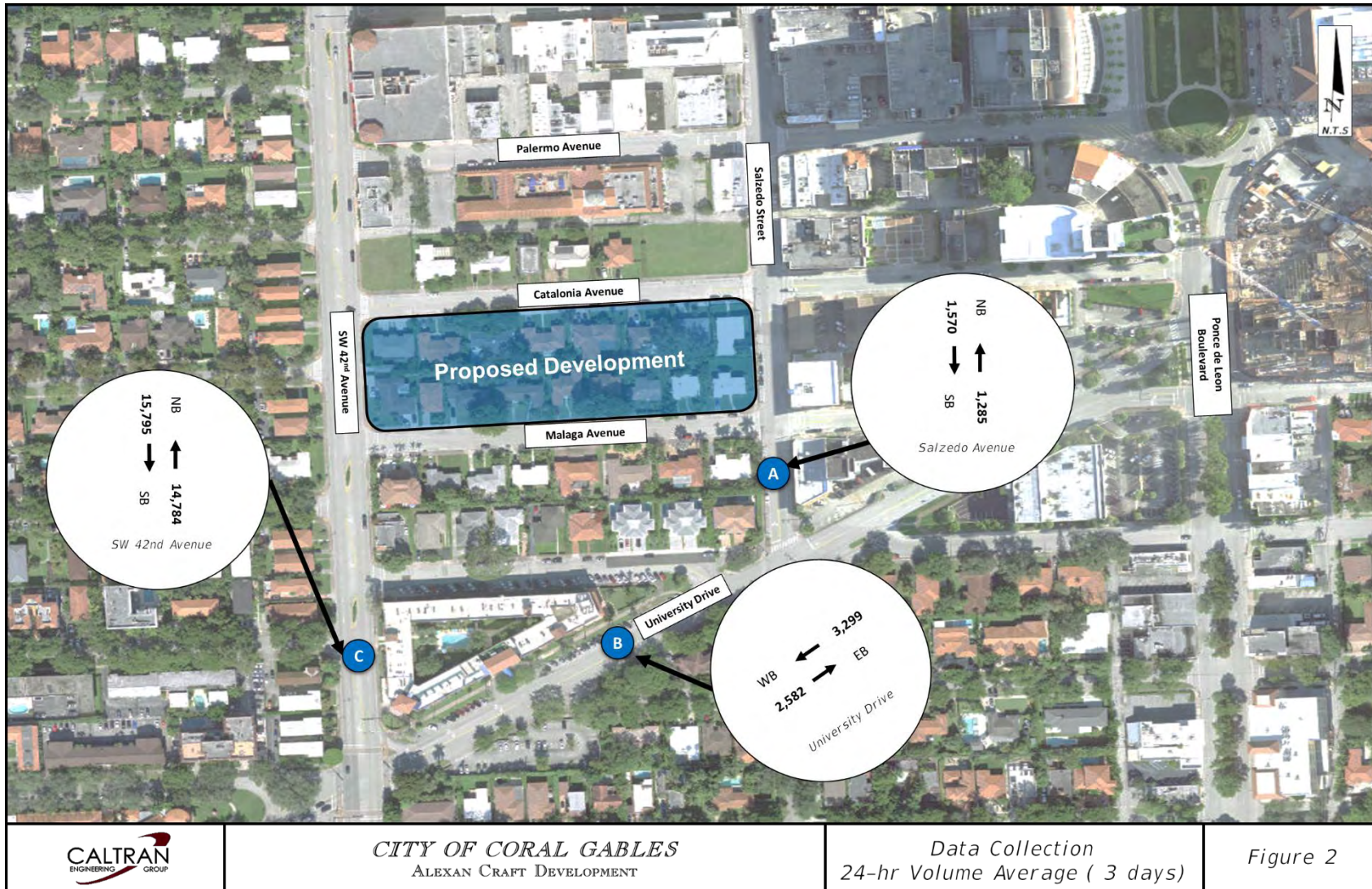
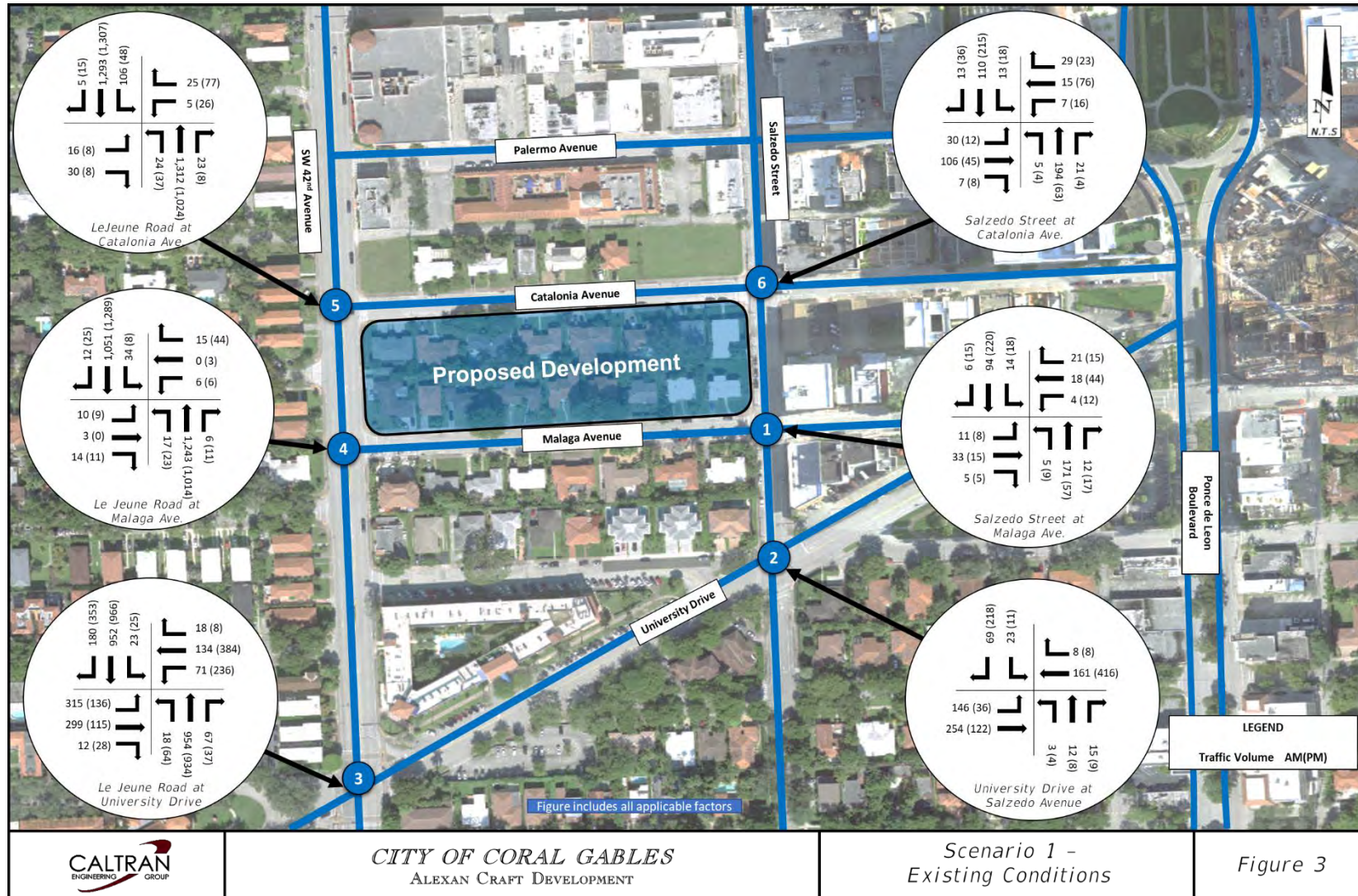


Figure 2: Daily Average Volumes



**Figure 3: Peak Hour Turning Movement Counts**

## 6.0 Scenario 2 – Future No Build-Out Condition and Growth Analysis

Consistent with background traffic historical trends, a growth rate is to be factored into the current traffic demands. Future traffic forecasts are developed for the years until expected build-out conditions for the development which was estimated to be 2025. Future No Build-Out Condition (Scenario 2) is the baseline in which the impact of the specific project is to be measured.

Traffic Growth Analysis for traffic historical data and SERPM 8.0 model data can be found on **Appendix C** and detailed information is presented in the following sections of this report.

### 6.1 Historical Traffic Data

Based on the FDOT 2020 Transportation Information On-line Portal, Traffic Monitoring Sites (TMS), Stations 87-0024 and 87-2534 were identified as the closest stations within the study area. **Table 4** summarizes the historical AADT (Annual Average Daily Traffic).

**Figure 4** shows the traffic monitoring sites location.

**Table 4: Historical AADT**

FDOT Historical AADT Data			
Traffic Station	Location	Year	AADT
87-0024	SR 953/LEJEUNE RD, 200' S CORAL WAY/SR 972	2016	36,000
		2017	31,500
		2018	32,500
		2019	32,000
		2020	27,000
87-2534	SR 972/CORAL WAY, 200' E SW 37 AVENUE	2016	42,000
		2017	30,000
		2018	32,500
		2019	32,500
		2020	26,000



Figure 4: Traffic Monitoring Sites

### 6.1.1 Historical Traffic Growth Rate Analysis

This analysis is based on the FDOT Monitoring Sites; forecasted traffic volumes for the Opening-Year (2025) that were obtained after analyzing and computing the appropriate and applicable forecast methodology at each segment.

- Regression analysis of 5 years of most recent historical AADTs from FDOT count sites.
- SERPM 8.0 Model outputs for the links at the FDOT count site for the base model year of 2015 and 2045 forecast year.

By Using the *FDOT-Traffic Trends Analysis Tool V3.0a.*, three regression analyses (Linear, Decaying, and Exponential Growth) were applied to the Historical AADT volumes on the two FDOT's Traffic Monitoring Sites to determine the historical annual growth rate as noted in **Table 5**.

**Table 5: Historical Growth Analysis Result**

Station	Method	R-Square (%)	Annual Growth (%)	Build-Out Year 2025 Forecasted Volumes
87-0024	Linear	74.15	-4.96	19,600
	Exponential	73.38	-5.44	21,400
	Decaying	71.09	-5.20	26,100
87-2534	Linear	62.74	-7.66	12,000
	Exponential	63.60	-8.43	17,400
	Decaying	71.68	-9.00	22,000

## 6.2 SERPM 8.0 Model Traffic Data

The latest Southeast Regional Planning Model (SERPM 8.0) was utilized for the forecasted year of 2045 by using 2015 as the base year. As per the SERPM Model network, highest AADT's variations between the years of 2015 to 2045 along the project limits were selected. **Table 6** presents a summary of SERPM 8.0 results with reference to the model output is provided in **Appendix C**.

**Table 6: SERPM 8.0 Volume Outputs**

Site Link	Year	AADT
87-0024	2015	38,270
	2045	43,415
87-2534	2015	29,524
	2045	33,938

### 6.2.1 Model Growth Rate Analysis

Model output data from the South East Regional Planning Model 8.0 (SERPM 8) was extracted for the validation year 2015 and the forecast year of 2045. The analysis utilized these output volumes and applied the three trends similar to the historical volumes growth rate analysis.

**Table 7: Model Growth Analysis Results**

Station	Method	Annual Growth (%)	Build-Out Year 2025 Forecasted Volumes
87-0024	Linear	0.44	40,000
	Exponential	0.42	39,900
	Decaying	0.43	41,900
87-2534	Linear	0.50	31,000
	Exponential	0.47	30,800
	Decaying	0.48	32,500

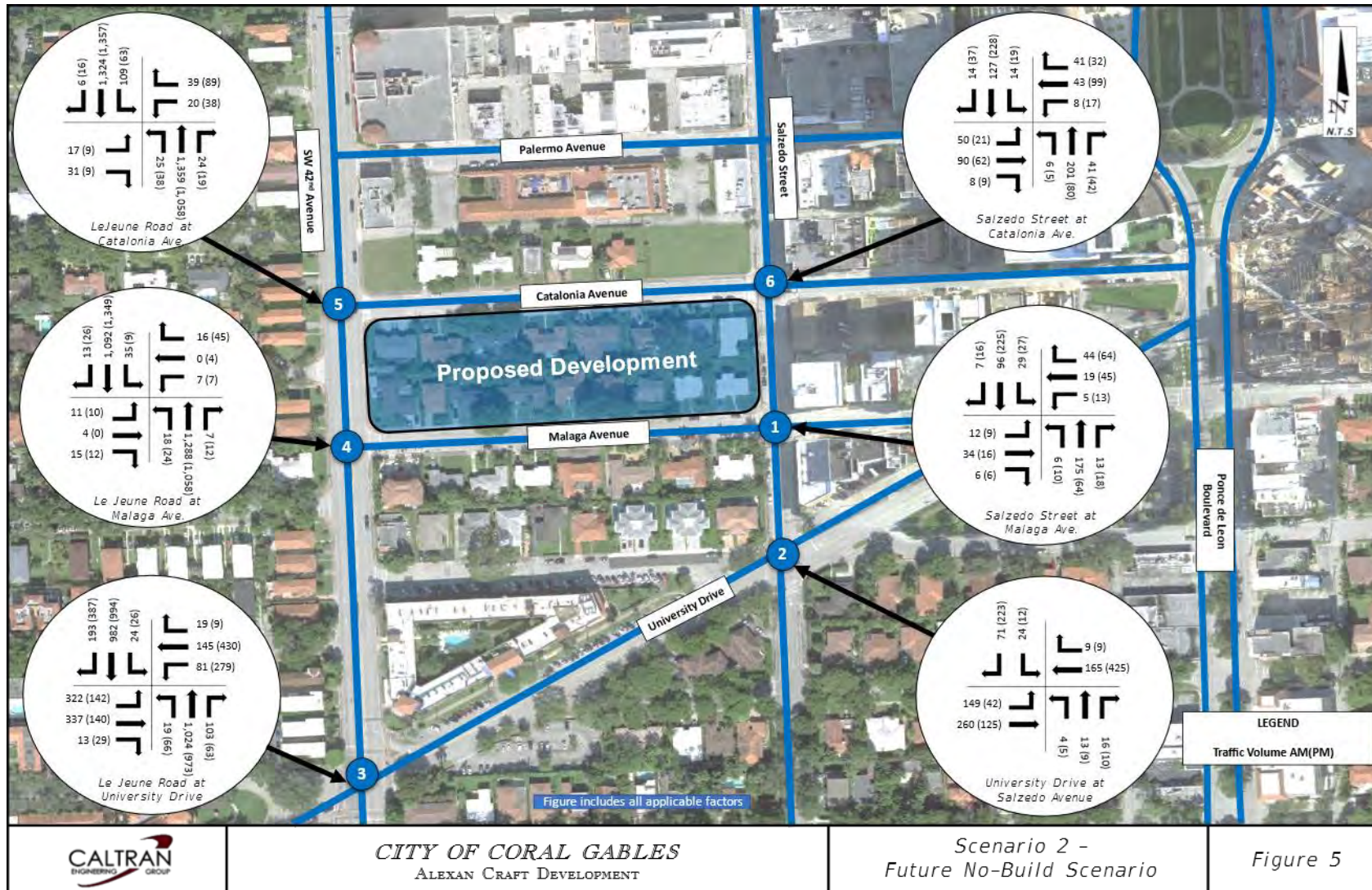
### 6.3 Growth Rate Determination

Based on the annual growth rates obtained from both analysis, traffic analysis zone (TAZ) patterns characteristics, knowledge of the area, and previous traffic growth analysis of the area which was performed, it was determined that a conservative 0.50% Annual Growth Rate consistent with the results from the SERPM 8.0 analysis, could be applied to the existing traffic network adjacent to the project site to forecast future annual traffic growth.



#### **6.4 Committed Developments and Work Program Projects**

A single committed developments was identified within vicinity of the proposed Alexan Craft Development area. The Ponce Park Tower development located on Catalonia Avenue between Salzedo Street and Ponce de Leon Boulevard. The Plaza at Coral Gables is a mixed-use development which has already begun construction, and includes median modifications along Ponce de Leon (access management modifications) and the signalization updates at the intersection of Ponce de Leon Boulevard and Malaga Avenue. The committed development volumes were added as part of Scenario 2 – Future No Build-Out condition. Refer to **Figure 5** for the traffic volumes of this scenario.



**Figure 5: Peak Hour Future No-Build Condition Traffic Volumes (Scenario 2)**

### 7.0 Scenario 3 – Future Conditions: Proposed Residential Development Build-Out Condition

Based on the results obtained in the Future Conditions (Scenario 2), the AM and PM peak hour trips expected to be generated by the proposed residential development are being added to the future network traffic conditions to develop the future built condition (Scenario 3).

#### 7.1 Proposed Development Trip Generation

Trip generation for the proposed development is based on the provided results from the Trip Generation Letter prepared by *Kimley-Horn and Associates, Inc.* The letter with its attachments can be found in **Appendix D**.

The proposed development of Alexan Craft is to be composed of multifamily residential units (mid-rise, LUC 210) encompassing 283 residential units with two (2) new driveway access points. The following table summarizes the net new trip generation for the proposed development:

**Table 8: Net New Trip Generation for the Proposed Development**

Condition	Development Size	Daily Trips		AM Peak Hour Trips		PM Peak Hour Trips	
		Entry	Exit	Entry	Exit	Entry	Exit
Existing	13 Single Family Detached Houses [ITE LUC 210]	74	74	4	9	8	5
Proposed	283 Multifamily Units (Mid-Rise) [ITE LUC 221]	710	710	23	65	67	44
Net New Trips		636	636	19	56	59	39

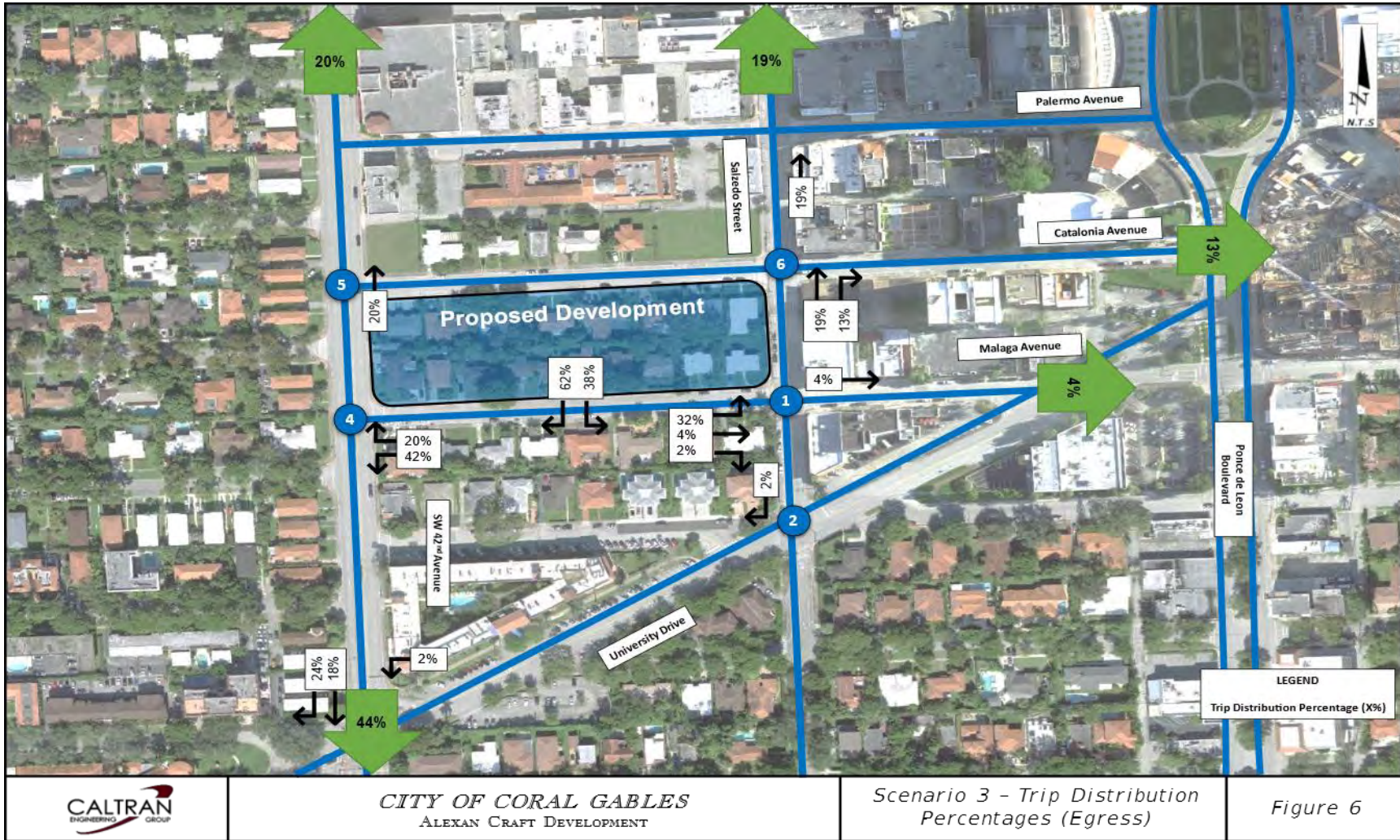
**7.2 Cardinal Trip Distribution (TAZ 1077)**

Trip distribution is a function of the original and destination of the site users and the available adjacent roadway system. Traffic circulation for Alexan Craft Development was determined based on the interpolation of the 2015-2045 Miami-Dade Long Range Transportation Plan (LRTP), Traffic Analysis Zone (TAZ 1077) traffic patterns, as well as, knowledge of traffic flow patterns and the roadway system in the area. **Table 9** shows the trip estimation from interpolation of the years 2015-2045 in the TAZ 1077:

**Table 9: Traffic Analysis Zones (TAZ 1077)**

Year	NNE	ENE	ESE	SSE	SSW	WSW	WNW	NNW	Total Trips
2015	2,105	1,507	469	238	2,141	1,625	1,255	2,227	11,567
Percentage	18.2%	13.0%	4.1%	2.1%	18.5%	14.0%	10.8%	19.3%	100%
2045	3,656	2,549	697	305	3,420	2,497	1,917	3,707	18,748
Percentage	19.5%	13.6%	3.7%	1.6%	18.2%	13.3%	10.2%	19.8%	100%
2021	2,674	1,889	553	263	2,610	1,945	1,498	2,770	14,200
Percentage	18.8%	13.3%	3.9%	1.8%	18.4%	13.7%	10.5%	19.5%	100%

TAZ Information from the LRTP year 2045 report can be found in **Appendix E**. The egress and ingress trip percentages are shown in **Figures 6 and 7**. The project new trips are shown in **Figure 8** and the future Traffic Volume for Future Build-out Condition (Scenario 3) is shown in **Figure 9**.



**Figure 6: Peak Hour Development Trip Distribution (Egress)**



**Figure 7: Peak Hour Development Trip Distribution (Ingress)**



Figure 8: Development Ingress/Egress Trip Distribution

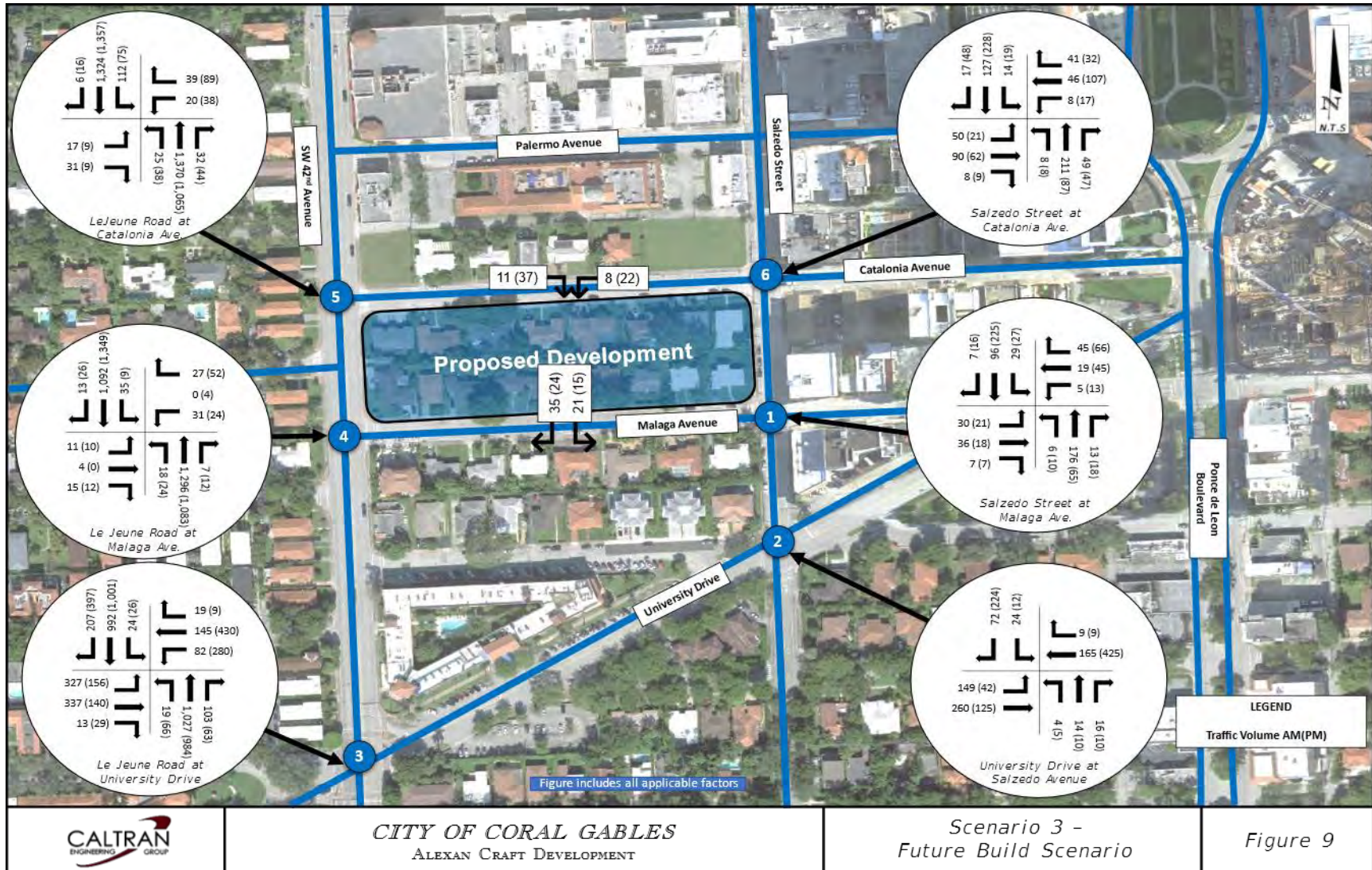


Figure 9: Future Build-Out Condition Peak Traffic Volumes (Scenario 3)



## **8.0 Level of Service Analysis**

This traffic analysis utilizes Synchro 11, which applies methodologies outlined in the Highway Capacity Manual, 6<sup>th</sup> Edition. Level of Service (LOS) Analysis for signalized/un-signalized intersections is based on the amount of control delay which is a measurement in seconds per vehicle that acts as an indicator of lost time, fuel consumption, frustration and driver’s discomfort at signalized intersections.

The LOS for signalized intersections is described by a scale that ranges from “A” to “F” in accordance with control delay thresholds that go from less than 10 seconds to greater than 80 seconds of delay per vehicle. Similarly, for unsignalized intersections the scale ranges from “A” to “F” in accordance with the average control delay thresholds that go from 0 seconds to greater than 50 seconds of delay per vehicle.

In order to perform this analysis, cycle lengths and clearance intervals used in the analysis are consistent with the current Miami-Dade County signal timing and signal operating plans for the study intersections in conjunction with physical and operational characteristics observed during peak hours. Signal Operation Plans (SOP) and Time of Day (TOD) schedules for two signalized intersections are available in **Appendix F**.

**Table 10** presents the Synchro Delay and LOS for the key intersections within the project area.

**Table 10: Roadway Network Level of Service Analysis**

Intersection	Approach	AM						PM						
		Scenario 1		Scenario 2		Scenario 3		Scenario 1		Scenario 2		Scenario 3		
		Delay	LOS	Delay	LOS	Delay	LOS	Delay	LOS	Delay	LOS	Delay	LOS	
SR-953 / SW 42nd Avenue / Le Jeune Road	Catalonia Avenue	EB	54.4	F	54.4	F	64.4	F	62.6	F	54.7	F	55.4	F
		WB	39.5	E	165.1	F	175.0	F	42.4	E	93.0	F	112.3	F
		NB	0.2	A	0.2	A	0.2	A	0.4	E	0.4	A	0.4	F
		SB	1.1	A	1.1	A	1.1	A	0.4	A	0.5	A	0.6	A
		Overall, EL <sup>(1)</sup>	1.0	A	3.9	A	4.1	A	2.0	A	4.8	A	5.7	A
		Overall, WL <sup>(2)</sup>	1.0	A	1.2	A	1.2	A	0.5	A	0.6	A	0.6	A
	Malaga Avenue	EB	32.6	D	36.8	E	36.8	E	42.4	E	49.7	E	50.9	F
		WB	32.9	D	38.9	E	115.6	F	18.9	C	21.3	C	43.8	E
		NB	0.1	A	0.2	A	0.1	A	0.3	A	0.3	A	0.3	A
		SB	1.1	A	1.3	A	1.4	A	0.3	A	0.4	A	0.4	A
		Overall, EL <sup>(1)</sup>	0.8	A	1.0	A	3.3	A	0.6	A	0.7	A	1.5	A
		Overall, WL <sup>(2)</sup>	0.4	A	0.5	A	0.4	A	0.5	A	0.6	A	0.6	A
	University Drive	EB	70.6	E	71.4	E	72.0	E	57.7	E	58.0	E	58.7	E
		WB	37.7	D	37.6	D	37.6	D	43.9	D	45.9	D	45.9	D
		NB	83.6	F	104.0	F	104.7	F	102.2	F	110.6	F	111.8	F
		SB	108.1	F	120.4	F	127.8	F	174.2	F	198.6	F	205.4	F
		Overall	88.7	F	101.6	F	105.0	F	119.4	F	131.3	F	134.6	F
	Salzedo Street	Catalonia Avenue	EB	9.0	A	9.4	A	9.5	A	8.3	A	8.9	A	9.1
WB			8.0	A	8.6	A	8.7	A	8.6	A	9.2	A	9.5	A
NB			9.3	A	9.8	A	10.1	B	8.2	A	8.7	A	8.9	A
SB			8.6	A	9.1	A	9.2	A	9.6	A	10.4	B	10.6	B
Overall			8.9	A	9.4	A	9.6	A	9.0	A	9.6	A	9.8	A
Malaga Avenue		EB	11.5	B	12.1	B	12.5	B	11.8	B	12.4	B	13.0	B
		WB	10.6	B	10.7	B	10.7	B	11.8	B	11.4	B	11.4	B
		NB	0.2	A	0.2	A	0.2	A	0.8	A	0.8	A	0.8	A
		SB	0.9	A	1.7	B	1.7	A	0.5	A	0.7	A	0.8	A
		Overall	2.9	A	3.6	A	4.1	A	3.1	A	4.0	A	4.3	A
University Drive		EB	21.5	C	21.5	C	21.5	C	43.0	D	43.3	D	43.3	D
		WB	18.8	B	18.7	B	18.7	B	44.6	D	43.9	D	43.9	D
	NB	5.6	A	5.8	A	5.8	A	4.2	A	4.5	A	4.5	A	
	Overall	6.0	A	6.2	A	6.2	A	5.2	A	5.6	A	5.6	A	
		18.1	B	18.0	B	18.0	B	32.4	C	32.2	C	32.2	C	

**Note:** Intersections of SW 42<sup>nd</sup> Avenue and Malaga/Catalonia are offset by ~120 feet. EL: Refers to east leg and WL refers to west leg of the intersection.

### 8.1 Mitigation Measures

A mitigation measure of signal re-timing is proposed for the intersection along SR-953 / SW 42nd Avenue / Le Jeune Road at University Drive during the AM and PM peak hour in Scenario 3 - Future Condition Build-Out based on the LOS analysis results. **Table 11** shows the operational analysis, which indicates that upon adjustments to the signal timing those intersections level of service will improve with an overall reduction of vehicular delays and Level of Service.

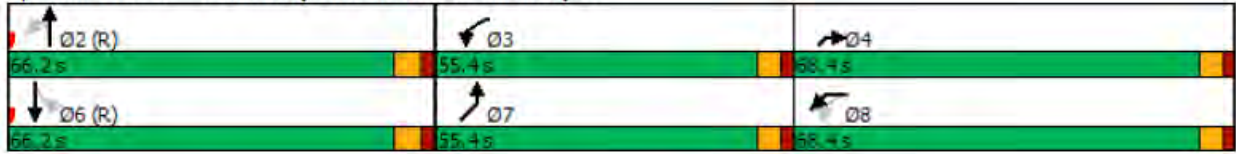
**Table 11: Analysis of Signal Retiming (AM/PM)**

Intersection	Approach	AM				PM			
		Scenario 3		Scenario 3 with Retiming		Scenario 3		Scenario 3 with Retiming	
		Delay	LOS	Delay	LOS	Delay	LOS	Delay	LOS
SR-953 / SW 42nd Avenue / Le Jeune Road at University Drive	EB	72.0	E	66.8	E	58.7	E	70.2	E
	WB	37.6	D	74.2	E	45.9	D	64.4	E
	NB	104.7	F	45.4	D	111.8	F	61.0	E
	SB	127.8	F	48.2	D	205.4	F	70.5	E
	Overall	105.0	F	51.3	D	134.6	F	66.1	E

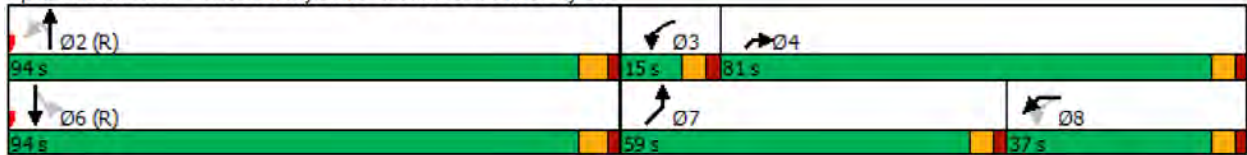
The described signal optimization was focused on improving mobility along the major street of SR-953 / SW 42nd Avenue / Le Jeune Road particularly. This timing maintains cycle lengths and offset and only redistributes the green time among the different phases. Finally, signal re-timing in coordination with Miami-Dade County Traffic and Signal Division is recommended as mitigation measure at the mentioned intersection.

**Figures 10 and 11** show existing and proposed timing for the signal splits.

Splits and Phases: 6: University Drive & SR 953 & University Dr.

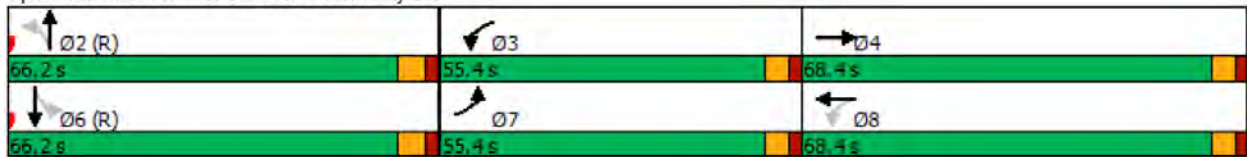


Splits and Phases: 6: University Drive & SR 953 & University Dr.

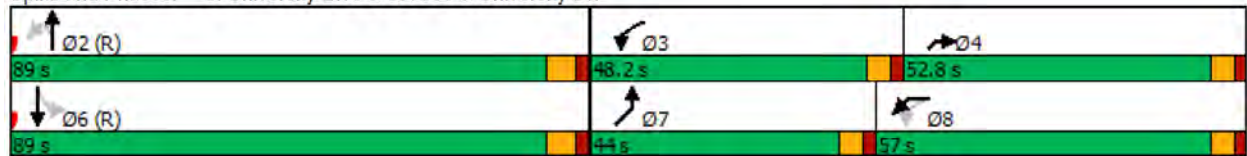


**Figure 10: AM Existing (top) and Proposed (bottom) Signal Splits for Plan 5**

Splits and Phases: 6: SR 953 & University Dr.



Splits and Phases: 6: University Drive & SR 953 & University Dr.



**Figure 11: PM Existing (top) and Proposed (bottom) Signal Splits for Plan 7**

### 9.0 Turn Lane Evaluation

A turn lane storage capacity analysis was performed to determine the adequacy of turn lane storage at the intersections to ensure that the exclusive turn lanes can provide sufficient storage for the 95<sup>th</sup> percentile queues expected as part of the future conditions. The 95<sup>th</sup> percentile queues lengths were obtained from the Trafficware SYNCHRO 11 SimTraffic Simulation. The results of the analysis are summarized in

**Table 12:**

**Table 12: Storage Length Capacity (Synchro 95<sup>th</sup> Percentile) Queues**

Intersection	Move ment	Storage Capacity	95 <sup>th</sup> Percentile queues accumulations in feet					
			Scenario 1		Scenario 2		Scenario 3	
			AM	PM	AM	PM	AM	PM
Le Jeune Road Catalonia Avenue	SBL	60 feet	25	0	25	0	25	0
Le Jeune Road at University Drive	NBL	200 feet	50	275	75	275	75	275
	SBL	80 feet	75	75	75	75	75	75
	EBL	225 feet	525	225	550	250	550	275
	WBL	500 feet	75	225	75	275	75	275
Salzedo Street at University Drive	NBL	175 feet	0	0	0	0	0	0

The turn lane analysis determined that all of the analyzed movements will be able to accommodate the expected 95<sup>th</sup> percentile queues, with the following exceptions:

- The northbound left lane queues at Lejeune Road with University Drive extends beyond the available storage capacity in all three scenarios in the PM peak period, however since this lane is back-to-back with a southbound left turn lane, it cannot be extended.
- The eastbound left at Lejeune Road with University Drive also extends over 300 feet past the available length in the AM period and up to 50 feet past in the PM periods, during all three analysis scenarios, extending this lane might require widening of the road.

- The unsignalized proposed driveways do not exceed thresholds for either left of right exclusive storage bays.

### 10.0 Concurrency Analysis

The study area traffic count stations on the roadway adjacent to the development site should be operating at an acceptable adopted level of service, during the highest peak hour period of the proposed development. Available capacity and acceptable level of service needs are to be maintained at the adjacent traffic station, as well as, within the area of influence and should meet the traffic concurrency standards from the City.

Capacity is defined as the maximum number of vehicles that can reasonably be expected to traverse over a specific section of roadway during a given time period and under the prevailing conditions.

As per the Florida Department of Transportation 2012 Quality/Level of Service Generalized Service Volume Table 4 (Peak Hour Bi-Directional Volumes), capacity analysis for each network concerned segment was performed for the AM and the PM peak periods, for existing and proposed operation conditions. An acceptable level of service for the segment should meet the minimum adopted LOS D thresholds. **Table 13** below summarizes the results of the calculations. For FDOT tables related to calculations, please refer to **Appendix G**.

**Table 13: Concurrency Analysis LOS Results**

Roadway Segment	Capacity (At LOS E)	Existing Trips	Development Trips	Future Trips with Development	Current LOS	Future LOS
Le Jeune Road	3,401	2,355 (AM)	32	2,387 (AM)	B	B
University Drive	2,584	690 (AM)	1	691 (AM)	B	B
Salzedo Street	987	309 (AM)	20	329 (AM)	B	B

## 11.0 Preliminary Signal Warrant

During the development of this study, a preliminary signal warrant study was completed for the intersection of Salzedo Street at Catalonia Avenue. The primary concern is that the intersection, during existing conditions, is an All-way-stop-controlled intersection, and adding any significant amount of traffic could possibly warrant a traffic signal. The preliminary signal warrant evaluated the analysis of the following MUTCD Chapter 4C Warrants:

### 11.1 Warrant 2, Four-Hour Vehicular Volume:

The Four-Hour Vehicular Volume signal warrant conditions are intended to be applied where the volume of intersecting traffic is the principal reason to consider installing a traffic control signal.

- A. The need for a traffic control signal shall be considered if an engineering study finds that, for each of any 4 hours of an average day, the plotted points representing the vehicles per hour on the major street (total of both approaches) and the corresponding vehicles per hour on the higher-volume minor-street approach (one direction only) all fall above the applicable curve in Figure 4C-1 for the existing combination of approach lanes. On the minor street, the higher volume shall not be required to be on the same approach during each of these 4 hours

**Analysis:** Out of the 4 examined hours, none of the hours fall above the required 100% line in **MUTCD Figure 4C-1**. As per the referenced figure, a major-street volume of approximately 400 vehicles per hour are required to intersect with a minimum of 310 vehicles per hour in the minor street. Since the maximum observed minor street approach volume is 118 vehicles/hour, the volume of intersecting traffic is very low and do not warrant a traffic signal at the intersection.

## 11.2 Warrant 7, Crash Experience

This signal warrant conditions are intended for application where the severity and frequency of crashes are the principal reasons to consider installing a traffic control signal. The warrant is satisfied when all 3 criteria are satisfied. The following are the criteria (A, B and C) required to satisfy the warrant:

**A.** Adequate trial of alternatives with satisfactory observance and enforcement has failed to reduce the crash frequency.

**Analysis:** No previous trial of alternatives with satisfactory observance and improvement has been documented at this intersection. Aerial imagery shows that the intersection was converted from a Two-way Stop-Controlled to an All-Way Stop-Controlled intersection somewhere in between May and December, 2017.

**B.** Five or more reported crashes, of types susceptible to correction by a traffic control signal, have occurred within a 12-month period, each crash involving personal injury or property damage apparently exceeding the applicable requirements for a reportable crash.

**Analysis:** Only 3 angle crashes at the intersection were found in the three-year review period within 12 consecutive months which is below the 5 required crashes.

**C.** For each of any 8 hours of an average day, the vehicles per hour (vph) given in both of the 80 percent columns of Condition A in Table 4C-1 (see Section 4C.02), or the vph in both of the 80 percent columns of Condition B in Table 4C-1 exists on the major-street and the higher-volume minor-street approach, respectively, to the intersection, or the volume of pedestrian traffic is not less than 80 percent of the requirements specified in the Pedestrian Volume warrant. These major-street and minor-street volumes shall be for the same 8 hours. On the minor street, the higher volume shall not be required to be on the same approach during each of the 8 hours.

**Analysis:** Not applicable.



### **11.3 Final Preliminary Signal Warrant Determination**

This cursory signal warrant evaluation concluded that a signal is not expected warranted based on MUTCD Section 4C (Warrants 2 and 7). The volume thresholds are below the required volumes thresholds to meet the warrants. At this time considering the data collection, a signal is not expected to be warranted at the intersection of Salzedo Street and Catalonia Avenue.

The cursory signal warrant analysis is included in **Appendix H**.

## **12.0 Conclusions and Recommendations**

This study analyzes the traffic impact of the proposed Alexan Craft Development, which is proposed to be a group of 283 multifamily residential units, in a site which currently contains 13 single family homes. Said proposed development will be bounded by Salcedo Street to the east, Lejeune Road to the west, Catalonia Avenue to the north, and Malaga Avenue to the south. The development site plans show proposed ingress and egress points at Catalonia Avenue and Malaga Avenue, respectively.

For the proposed development trip generation analysis contemplated the most conservative scenario of trip generation forecast rates. The trip generation analysis was performed under the following ITE land uses:

- 210 – Single-Family
- 221 - Multifamily Housing (Mid-Rise)

As the trip generation letter prepared by Kimley-Horn & Associates for this development concluded, the Scenario 3 of the Alexan Craft development could generate about 1,272 net new daily trips and a maximum of 75 and 98 net new trips for the AM and PM peak period of the adjacent roadway, respectively. The following are the final observations:

- The level of service (LOS) analysis concluded that the two main signalized intersections adjacent to the development are expected to maintain their current LOS in all three studied scenarios. The intersection of SR-953 / SW 42nd Avenue / Le Jeune Road at University Drive is expected to maintain current LOS F in both the AM and PM peak hours. Similarly, the intersection of Salcedo Street at University Drive will maintain current LOS B in the AM peak period and LOS C in the PM peak periods.

- The level of service (LOS) analysis concluded that the unsignalized intersections are expected to also maintain their current operational LOS. The intersection of Salzedo Street with Malaga Avenue will maintain LOS A during both the AM and PM peak periods. The intersection of Salzedo Street at Catalonia that is an All-Way Stop-Controlled intersection will be also maintaining current LOS A in both peak periods.
- The intersection of SR-953 / SW 42nd Avenue / Le Jeune Road at Malaga Avenue is expected to show increased delay in the AM peak period in the westbound direction, going from LOS E to LOS F in future build-out conditions (Scenario 3). The minor street approach also will experience an increase in delay during the PM peak period.
- There is another Two-Way Stop-Controlled intersection at SR-953 / SW 42nd Avenue / Le Jeune Road at Catalonia Avenue which is expected also to have a detrimental in LOS in the AM and PM as delay increase in the minor approach. It is worth noting that even though the delay appears to be high, the traffic volumes at these locations is very low (less than 50 vehicles in the peak period).
- As a mitigation measure, at the intersection of SR-953 / SW 42<sup>nd</sup> Avenue / Le Jeune Road and University Drive, it is recommended to perform signal re-timing in coordination with Miami-Dade County Traffic and Signal Division as a mitigation measure at the mentioned intersection.

- The turn lane evaluation analysis concluded that the signalized intersection of SR-953 / SW 42<sup>nd</sup> Avenue / Le Jeune Road at University Drive shows slight increases in queue accumulations in the northbound and eastbound left turn lanes. The eastbound left already exceeds the storage capacity of 225 feet with queues extending up to 525 feet under the existing condition (Scenario 1) to a maximum of 550 feet on future build-out conditions (Scenario 3). Thus, extending the eastbound left turn lane would require widening along University Drive which could bring impacts to mature trees. In the case of the northbound left queues which also are extending beyond the available storage distance in the PM peak period on all three scenarios, this movement is constrained due to a back-to-back storage bay for the southbound left into Sarto Avenue (south of University Drive).
- As part of this study, a preliminary signal warrant analysis was conducted using MUTCD Chapter 4C. This study was performed at the all-way stop-controlled intersection of Salzedo Street and Catalonia Avenue, and focused particularly on Warrants 2 and 7. The intersection did not meet any of the two examined warrant thresholds and is not expected to warrant a signal at this location.

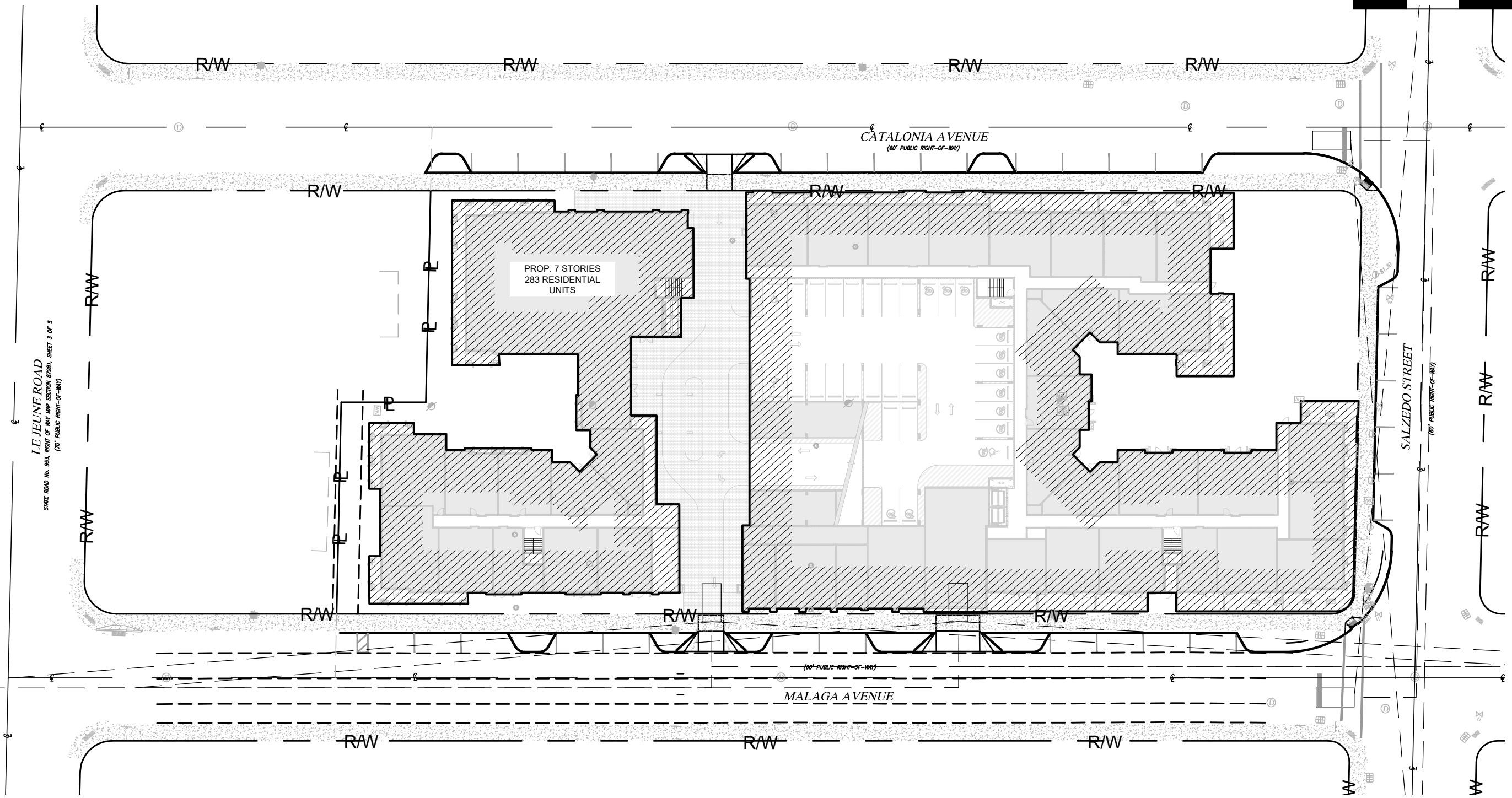
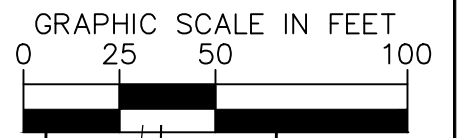
Based on the findings, the traffic impacts associated to the proposed development of Alexan Craft concluded that most of the intersections will maintain conditions that are similar to the baseline conditions presented in future no-build conditions (Scenario 2).

As a result, the proposed development of Alexan Craft is not expected to have a negative impact in the surrounding roadway network.

# **Appendix A**

## Development Site Plan

Plotted By: Giraldo, Maggie Sheet Set: Kha Layout: Layout1 June 15, 2021 01:22:03pm K:\MIB\_Civil\043904007 - Alexan Crafts (Coral Gables)\CIVIL\CADD\Exhibits\2021.03.25\PROJECT SITE.dwg  
This document, together with the concepts and designs presented herein, is intended only for the specific purpose and client for which it was prepared. Reuse of and improper reliance on this document without written authorization and adaptation by Kimley-Horn and Associates, Inc. shall be without liability to Kimley-Horn and Associates, Inc.



© 2021 KIMLEY-HORN AND ASSOCIATES, INC.  
355 ALHAMBRA CIRCLE, SUITE 1400, CORAL GABLES, FL 33134  
PHONE: 305-673-2025  
WWW.KIMLEY-HORN.COM REGISTRY 696

ALEXAN CRAFTS

330 CATALONIA AVE

SHEET NUMBER

1

# **Appendix B**

## Data Collection / Field Pictures

# 72-Hour Volume Counts



County: 99  
 Station: 1245  
 Description: SALZEDO STREET NORTH OF UNIVERSITY DR  
 Start Date: 08/31/2021  
 Start Time: 0000

Time	Direction: N					Direction: S					Combined Total	
	1st	2nd	3rd	4th	Total	1st	2nd	3rd	4th	Total		
0000	0	0	0	0	0	0	0	0	0	0	0	
0100	0	0	0	0	0	0	0	0	0	0	0	
0200	0	0	0	0	0	2	0	0	0	2	2	
0300	0	0	0	0	0	0	0	0	1	1	1	
0400	0	0	1	1	2	0	2	0	0	2	4	
0500	1	0	3	2	6	0	3	1	2	6	12	
0600	4	9	8	18	39	2	7	3	9	21	60	
0700	11	15	14	24	64	4	6	8	16	34	98	
0800	31	33	32	66	162	19	25	26	18	88	250	
0900	72	44	39	43	198	23	28	10	16	77	275	
1000	23	27	43	27	120	28	17	20	29	94	214	
1100	24	25	19	30	98	22	22	18	20	82	180	
1200	26	18	25	30	99	30	29	24	32	115	214	
1300	27	17	16	16	76	27	38	26	28	119	195	
1400	15	25	24	20	84	38	33	33	35	139	223	
1500	14	25	18	17	74	42	41	37	28	148	222	
1600	11	18	24	12	65	33	35	38	34	140	205	
1700	16	14	11	6	47	59	62	47	39	207	254	
1800	12	7	11	10	40	53	45	33	19	150	190	
1900	11	4	10	4	29	34	23	25	14	96	125	
2000	2	3	12	1	18	15	9	13	3	40	58	
2100	0	3	2	1	6	7	5	9	4	25	31	
2200	3	0	1	0	4	4	1	2	2	9	13	
2300	0	1	0	0	1	1	1	0	2	4	5	
24-Hour Totals:					1232						1599	2831

Peak Volume Information						
	Direction: N		Direction: S		Combined Directions	
	Hour	Volume	Hour	Volume	Hour	Volume
A.M.	845	221	830	95	830	309
P.M.	1215	100	1700	207	1630	259
Daily	845	221	1700	207	830	309

County: 99  
 Station: 1245  
 Description: SALZEDO STREET NORTH OF UNIVERSITY DR  
 Start Date: 09/01/2021  
 Start Time: 0000

Time	Direction: N					Direction: S					Combined Total	
	1st	2nd	3rd	4th	Total	1st	2nd	3rd	4th	Total		
0000	0	0	1	0	1	0	1	0	0	1	2	
0100	0	0	1	0	1	0	0	1	0	1	2	
0200	0	0	0	0	0	0	0	0	0	0	0	
0300	0	0	0	0	0	0	0	0	0	0	0	
0400	0	0	2	0	2	0	0	0	0	0	2	
0500	3	3	1	2	9	0	2	1	4	7	16	
0600	5	7	9	18	39	0	5	3	3	11	50	
0700	15	25	23	27	90	4	8	13	15	40	130	
0800	27	42	54	48	171	13	25	23	25	86	257	
0900	47	39	46	45	177	23	24	22	15	84	261	
1000	37	31	30	35	133	14	19	22	26	81	214	
1100	38	13	17	12	80	26	25	27	28	106	186	
1200	18	19	19	32	88	34	21	25	33	113	201	
1300	26	22	23	22	93	31	27	27	30	115	208	
1400	30	17	14	29	90	43	40	30	24	137	227	
1500	33	13	23	23	92	40	31	44	29	144	236	
1600	23	29	20	15	87	25	38	35	38	136	223	
1700	37	20	12	17	86	66	57	48	42	213	299	
1800	16	13	9	10	48	46	48	40	42	176	224	
1900	9	7	7	5	28	25	21	13	8	67	95	
2000	7	5	6	3	21	10	11	11	11	43	64	
2100	1	0	5	1	7	6	4	2	5	17	24	
2200	0	0	1	0	1	3	5	5	3	16	17	
2300	2	0	0	0	2	1	2	2	1	6	8	
24-Hour Totals:					1346						1600	2946

	Peak Volume Information					
	Direction: N		Direction: S		Combined Directions	
	Hour	Volume	Hour	Volume	Hour	Volume
A.M.	815	191	815	96	815	287
P.M.	1245	103	1700	213	1700	299
Daily	815	191	1700	213	1700	299

County: 99  
 Station: 1245  
 Description: SALZEDO STREET NORTH OF UNIVERSITY DR  
 Start Date: 09/02/2021  
 Start Time: 0000

Time	Direction: N					Direction: S					Combined Total		
	1st	2nd	3rd	4th	Total	1st	2nd	3rd	4th	Total			
0000	0	0	0	0	0	3	2	1	1	7	7		
0100	0	0	0	1	1	0	0	0	8	8	9		
0200	0	0	0	0	0	0	0	0	1	1	1		
0300	0	0	0	0	0	0	0	0	0	0	0		
0400	0	0	0	2	2	0	0	0	0	0	2		
0500	0	2	1	1	4	0	2	0	2	4	8		
0600	3	8	9	17	37	2	0	2	5	9	46		
0700	17	18	15	17	67	4	14	6	14	38	105		
0800	40	38	45	54	177	19	20	23	23	85	262		
0900	43	48	29	44	164	18	22	17	19	76	240		
1000	28	29	28	20	105	19	16	16	35	86	191		
1100	31	19	35	16	101	25	31	23	25	104	205		
1200	27	23	24	20	94	33	29	22	32	116	210		
1300	19	35	20	16	90	28	18	21	28	95	185		
1400	17	14	34	16	81	42	36	37	34	149	230		
1500	16	18	35	27	96	23	36	42	16	117	213		
1600	16	28	24	26	94	41	26	31	49	147	241		
1700	28	18	11	13	70	60	50	60	36	206	276		
1800	20	7	8	12	47	61	40	22	25	148	195		
1900	7	5	7	3	22	27	18	7	10	62	84		
2000	5	9	1	0	15	8	11	6	4	29	44		
2100	5	1	1	2	9	3	1	2	4	10	19		
2200	0	0	0	1	1	3	3	3	1	10	11		
2300	0	0	0	0	0	3	0	0	1	4	4		
<b>24-Hour Totals:</b>						<b>1277</b>						<b>1511</b>	<b>2788</b>

	Peak Volume Information					
	Direction: N		Direction: S		Combined Directions	
	Hour	Volume	Hour	Volume	Hour	Volume
A.M.	830	190	830	86	830	276
P.M.	1530	106	1645	219	1645	302
Daily	830	190	1645	219	1645	302

County: 99  
 Station: 1246  
 Description: LE JEUNE RD NORTH OF UNIVERSITY DR  
 Start Date: 08/31/2021  
 Start Time: 0000

Time	Direction: N					Direction: S					Combined Total		
	1st	2nd	3rd	4th	Total	1st	2nd	3rd	4th	Total			
0000	24	20	14	10	68	28	25	15	10	78	146		
0100	13	8	3	9	33	17	11	7	9	44	77		
0200	7	3	8	5	23	12	5	4	11	32	55		
0300	5	9	10	9	33	5	4	4	12	25	58		
0400	11	16	20	22	69	8	4	17	20	49	118		
0500	25	33	33	65	156	18	38	47	53	156	312		
0600	81	96	155	232	564	78	160	249	261	748	1312		
0700	276	227	208	246	957	231	227	285	279	1022	1979		
0800	277	309	318	318	1222	290	284	285	265	1124	2346		
0900	300	270	243	300	1113	276	247	218	233	974	2087		
1000	233	225	222	228	908	225	223	220	226	894	1802		
1100	238	225	233	217	913	226	227	237	260	950	1863		
1200	247	234	220	262	963	265	249	234	291	1039	2002		
1300	261	231	210	262	964	275	247	283	308	1113	2077		
1400	212	186	305	295	998	294	312	300	288	1194	2192		
1500	257	227	277	257	1018	273	302	310	268	1153	2171		
1600	243	278	248	265	1034	257	261	267	265	1050	2084		
1700	258	274	212	207	951	340	302	311	345	1298	2249		
1800	261	224	190	176	851	370	288	245	227	1130	1981		
1900	184	169	183	152	688	215	191	184	151	741	1429		
2000	139	153	122	134	548	141	127	111	142	521	1069		
2100	96	112	96	69	373	123	102	93	82	400	773		
2200	71	59	59	48	237	86	70	74	55	285	522		
2300	56	33	33	29	151	51	48	35	36	170	321		
<b>24-Hour Totals:</b>						<b>14835</b>						<b>16190</b>	<b>31025</b>

	Peak Volume Information					
	Direction: N		Direction: S		Combined Directions	
	Hour	Volume	Hour	Volume	Hour	Volume
A.M.	815	1245	730	1138	815	2355
P.M.	1430	1084	1715	1328	1715	2282
Daily	815	1245	1715	1328	815	2355

County: 99  
 Station: 1246  
 Description: LE JEUNE RD NORTH OF UNIVERSITY DR  
 Start Date: 09/01/2021  
 Start Time: 0000

Time	Direction: N					Direction: S					Combined Total		
	1st	2nd	3rd	4th	Total	1st	2nd	3rd	4th	Total			
0000	27	21	15	7	70	24	28	21	15	88	158		
0100	14	14	6	6	40	17	11	9	5	42	82		
0200	10	6	5	2	23	8	19	8	8	43	66		
0300	9	5	5	8	27	4	8	2	3	17	44		
0400	15	14	16	24	69	9	15	6	18	48	117		
0500	30	36	42	78	186	21	43	53	56	173	359		
0600	61	104	151	243	559	72	133	221	293	719	1278		
0700	279	221	206	242	948	271	174	230	292	967	1915		
0800	248	272	333	302	1155	263	293	265	257	1078	2233		
0900	307	300	259	258	1124	236	234	225	215	910	2034		
1000	277	261	248	225	1011	176	205	197	215	793	1804		
1100	219	219	236	230	904	206	217	216	222	861	1765		
1200	261	228	255	241	985	240	201	220	248	909	1894		
1300	245	249	211	210	915	247	254	250	302	1053	1968		
1400	231	226	324	283	1064	306	300	253	247	1106	2170		
1500	223	191	278	211	903	236	285	272	233	1026	1929		
1600	277	293	257	196	1023	259	237	267	195	958	1981		
1700	269	270	225	183	947	336	312	285	319	1252	2199		
1800	258	223	209	192	882	317	255	252	281	1105	1987		
1900	199	173	172	162	706	253	192	170	134	749	1455		
2000	149	145	141	99	534	153	136	123	126	538	1072		
2100	104	82	104	91	381	107	116	93	108	424	805		
2200	90	86	69	56	301	73	99	81	56	309	610		
2300	55	51	38	31	175	51	44	38	33	166	341		
<b>24-Hour Totals:</b>						<b>14932</b>						<b>15334</b>	<b>30266</b>

	Peak Volume Information					
	Direction: N		Direction: S		Combined Directions	
	Hour	Volume	Hour	Volume	Hour	Volume
A.M.	830	1242	745	1113	815	2265
P.M.	1400	1064	1700	1252	1700	2199
Daily	830	1242	1700	1252	815	2265

County: 99  
 Station: 1246  
 Description: LE JEUNE RD NORTH OF UNIVERSITY DR  
 Start Date: 09/02/2021  
 Start Time: 0000

Time	Direction: N					Direction: S					Combined Total
	1st	2nd	3rd	4th	Total	1st	2nd	3rd	4th	Total	
0000	33	32	18	15	98	39	28	31	18	116	214
0100	19	21	12	5	57	19	9	12	13	53	110
0200	7	5	5	8	25	16	8	5	3	32	57
0300	3	9	6	11	29	3	7	15	12	37	66
0400	8	11	25	20	64	2	11	10	20	43	107
0500	30	34	55	79	198	15	26	56	60	157	355
0600	76	105	156	239	576	76	126	235	321	758	1334
0700	317	233	223	245	1018	263	212	233	303	1011	2029
0800	272	307	308	311	1198	270	282	288	253	1093	2291
0900	294	263	238	271	1066	229	218	194	198	839	1905
1000	225	226	221	246	918	216	171	179	212	778	1696
1100	237	255	224	233	949	205	200	219	205	829	1778
1200	238	237	246	251	972	244	210	248	241	943	1915
1300	272	207	209	211	899	214	254	244	261	973	1872
1400	202	190	293	269	954	378	432	297	291	1398	2352
1500	246	203	285	254	988	248	322	290	265	1125	2113
1600	262	286	262	195	1005	276	276	306	270	1128	2133
1700	239	235	208	185	867	345	334	341	335	1355	2222
1800	226	244	181	164	815	393	345	257	253	1248	2063
1900	182	156	144	146	628	239	170	168	151	728	1356
2000	145	132	126	113	516	147	127	92	106	472	988
2100	114	94	86	70	364	103	69	98	79	349	713
2200	81	50	54	48	233	72	53	63	49	237	470
2300	56	37	29	27	149	55	41	30	33	159	308
<b>24-Hour Totals:</b>	<b>14586</b>					<b>15861</b>					<b>30447</b>

	Peak Volume Information					
	Direction: N		Direction: S		Combined Directions	
	Hour	Volume	Hour	Volume	Hour	Volume
A.M.	815	1220	745	1143	800	2291
P.M.	1530	1087	1730	1414	1400	2352
Daily	815	1220	1730	1414	1400	2352

County: 99  
 Station: 1247  
 Description: UNIVERSITY DR EAST OF LE JEUNE RD  
 Start Date: 08/31/2021  
 Start Time: 0000

Time	Direction: E					Direction: W					Combined Total	
	1st	2nd	3rd	4th	Total	1st	2nd	3rd	4th	Total		
0000	1	1	0	1	3	5	0	2	4	11	14	
0100	0	1	0	0	1	2	3	2	1	8	9	
0200	0	1	0	1	2	1	0	0	0	1	3	
0300	0	0	1	0	1	1	0	0	0	1	2	
0400	0	0	1	1	2	1	0	0	0	1	3	
0500	2	3	5	5	15	1	0	3	1	5	20	
0600	9	10	16	72	107	0	6	9	26	41	148	
0700	80	75	69	81	305	30	26	40	45	141	446	
0800	68	94	92	110	364	52	45	60	48	205	569	
0900	79	76	62	57	274	37	33	36	35	141	415	
1000	56	34	35	36	161	34	29	41	32	136	297	
1100	25	25	20	28	98	39	38	44	37	158	256	
1200	38	37	24	28	127	45	60	49	49	203	330	
1300	33	31	29	27	120	40	66	55	65	226	346	
1400	20	27	29	24	100	71	59	66	64	260	360	
1500	31	24	26	29	110	63	64	67	67	261	371	
1600	29	41	44	31	145	88	91	115	94	388	533	
1700	30	40	51	36	157	140	146	128	119	533	690	
1800	25	13	28	27	93	92	93	59	62	306	399	
1900	19	13	15	14	61	55	43	39	44	181	242	
2000	9	10	10	3	32	43	21	26	22	112	144	
2100	8	5	2	2	17	19	14	9	6	48	65	
2200	10	3	4	1	18	8	7	7	9	31	49	
2300	2	0	0	0	2	4	9	2	3	18	20	
24-Hour Totals:					2315						3416	5731

	Peak Volume Information					
	Direction: E		Direction: W		Combined Directions	
	Hour	Volume	Hour	Volume	Hour	Volume
A.M.	815	375	800	205	800	569
P.M.	1700	157	1700	533	1700	690
Daily	815	375	1700	533	1700	690

County: 99  
 Station: 1247  
 Description: UNIVERSITY DR EAST OF LE JEUNE RD  
 Start Date: 09/01/2021  
 Start Time: 0000

Time	Direction: E					Direction: W					Combined Total		
	1st	2nd	3rd	4th	Total	1st	2nd	3rd	4th	Total			
0000	2	0	0	1	3	2	1	2	0	5	8		
0100	0	0	0	0	0	0	0	1	0	1	1		
0200	0	0	0	0	0	0	0	0	1	1	1		
0300	0	0	0	0	0	0	0	0	0	0	0		
0400	0	0	0	1	1	2	0	2	1	5	6		
0500	1	2	0	3	6	0	1	1	2	4	10		
0600	2	12	26	57	97	6	5	18	24	53	150		
0700	78	57	69	90	294	26	27	34	43	130	424		
0800	90	69	85	114	358	52	52	69	55	228	586		
0900	110	72	81	72	335	40	30	33	43	146	481		
1000	52	43	52	51	198	39	47	42	31	159	357		
1100	42	30	38	35	145	45	38	45	49	177	322		
1200	28	35	31	33	127	43	51	60	55	209	336		
1300	41	36	33	41	151	64	54	64	65	247	398		
1400	44	45	73	79	241	74	65	62	48	249	490		
1500	52	52	36	39	179	66	68	67	74	275	454		
1600	39	23	30	53	145	65	72	94	67	298	443		
1700	43	50	27	41	161	88	106	86	77	357	518		
1800	26	26	18	26	96	76	75	48	47	246	342		
1900	26	24	12	9	71	49	40	51	37	177	248		
2000	12	16	13	13	54	40	32	20	21	113	167		
2100	6	10	5	3	24	23	15	17	12	67	91		
2200	5	5	1	0	11	7	11	9	14	41	52		
2300	2	1	2	3	8	4	1	6	5	16	24		
<b>24-Hour Totals:</b>						<b>2705</b>						<b>3204</b>	<b>5909</b>

	Peak Volume Information					
	Direction: E		Direction: W		Combined Directions	
	Hour	Volume	Hour	Volume	Hour	Volume
A.M.	830	381	800	228	815	594
P.M.	1430	256	1700	357	1630	531
Daily	830	381	1700	357	815	594



County: 99  
 Station: 1247  
 Description: UNIVERSITY DR EAST OF LE JEUNE RD  
 Start Date: 09/02/2021  
 Start Time: 0000

Time	Direction: E					Direction: W					Combined Total		
	1st	2nd	3rd	4th	Total	1st	2nd	3rd	4th	Total			
0000	2	1	0	1	4	5	4	1	3	13	17		
0100	0	0	0	0	0	3	0	1	1	5	5		
0200	0	0	0	1	1	1	1	2	0	4	5		
0300	0	1	0	0	1	0	0	0	0	0	1		
0400	0	0	1	2	3	0	1	0	1	2	5		
0500	1	4	6	4	15	0	5	0	3	8	23		
0600	8	12	18	76	114	3	6	13	20	42	156		
0700	88	84	71	83	326	18	19	39	28	104	430		
0800	78	92	97	115	382	31	39	52	41	163	545		
0900	101	93	65	71	330	39	29	31	24	123	453		
1000	70	49	48	40	207	37	36	28	49	150	357		
1100	50	43	42	51	186	43	42	49	45	179	365		
1200	34	35	37	50	156	42	50	42	57	191	347		
1300	40	40	38	45	163	34	41	36	74	185	348		
1400	41	36	81	70	228	72	83	59	73	287	515		
1500	47	39	26	22	134	40	53	62	93	248	382		
1600	20	32	30	29	111	96	82	108	105	391	502		
1700	28	35	44	40	147	118	102	97	116	433	580		
1800	21	18	23	25	87	94	109	74	56	333	420		
1900	21	15	12	10	58	56	51	44	30	181	239		
2000	11	9	11	4	35	30	28	27	22	107	142		
2100	6	7	1	1	15	12	15	13	20	60	75		
2200	8	2	5	2	17	16	16	4	13	49	66		
2300	3	1	1	0	5	9	5	2	4	20	25		
<b>24-Hour Totals:</b>						<b>2725</b>						<b>3278</b>	<b>6003</b>

	Peak Volume Information					
	Direction: E		Direction: W		Combined Directions	
	Hour	Volume	Hour	Volume	Hour	Volume
A.M.	830	406	815	171	815	576
P.M.	1430	237	1630	433	1700	580
Daily	830	406	1630	433	1700	580

# Turning Movement Counts (TMC)

# University Dr at Salzedo Street

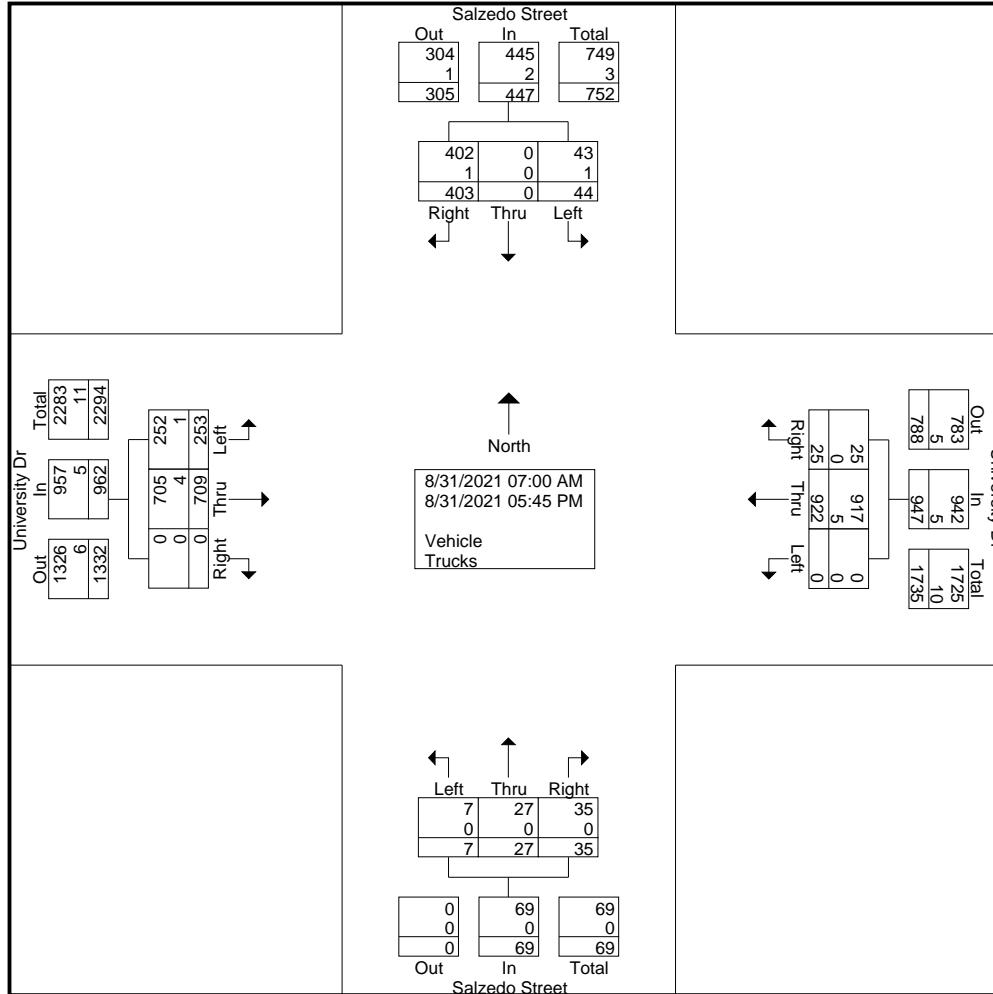
File Name : TMC-1 University Dr at Salzedo Street  
 Site Code : 00000000  
 Start Date : 8/31/2021  
 Page No : 1

## Groups Printed- Vehicle - Trucks

Start Time	Salzedo Street Southbound					Salzedo Street Northbound					University Dr Westbound					University Dr Eastbound					Int. Total
	U-Turns	Left	Thru	Right	App. Total	U-Turns	Left	Thru	Right	App. Total	U-Turns	Left	Thru	Right	App. Total	U-Turns	Left	Thru	Right	App. Total	
07:00 AM	0	1	0	3	4	0	0	1	1	2	0	0	25	0	25	0	8	73	0	81	112
07:15 AM	0	0	0	5	5	0	0	1	4	5	0	0	24	1	25	0	10	62	0	72	107
07:30 AM	0	3	0	4	7	0	0	2	0	2	0	0	38	1	39	0	8	59	0	67	115
07:45 AM	0	3	0	10	13	0	0	2	3	5	0	0	34	2	36	0	22	61	0	83	137
<b>Total</b>	<b>0</b>	<b>7</b>	<b>0</b>	<b>22</b>	<b>29</b>	<b>0</b>	<b>0</b>	<b>6</b>	<b>8</b>	<b>14</b>	<b>0</b>	<b>0</b>	<b>121</b>	<b>4</b>	<b>125</b>	<b>0</b>	<b>48</b>	<b>255</b>	<b>0</b>	<b>303</b>	<b>471</b>
08:00 AM	0	4	0	13	17	0	1	2	3	6	0	0	43	2	45	0	23	52	0	75	143
08:15 AM	0	8	0	13	21	0	0	0	3	3	0	0	35	1	36	0	27	67	0	94	154
08:30 AM	0	6	0	20	26	0	0	2	5	7	0	0	43	2	45	0	27	50	0	77	155
08:45 AM	0	2	0	16	18	0	0	6	1	7	0	0	25	1	26	0	55	62	0	117	168
<b>Total</b>	<b>0</b>	<b>20</b>	<b>0</b>	<b>62</b>	<b>82</b>	<b>0</b>	<b>1</b>	<b>10</b>	<b>12</b>	<b>23</b>	<b>0</b>	<b>0</b>	<b>146</b>	<b>6</b>	<b>152</b>	<b>0</b>	<b>132</b>	<b>231</b>	<b>0</b>	<b>363</b>	<b>620</b>
*** BREAK ***																					
04:00 PM	0	3	0	26	29	0	1	1	2	4	0	0	65	1	66	0	8	23	0	31	130
04:15 PM	0	0	0	31	31	0	1	2	0	3	0	0	68	2	70	0	11	34	0	45	149
04:30 PM	0	4	0	35	39	0	2	1	2	5	0	0	81	2	83	0	17	31	0	48	175
04:45 PM	0	1	0	32	33	0	0	1	4	5	0	0	68	4	72	0	6	26	0	32	142
<b>Total</b>	<b>0</b>	<b>8</b>	<b>0</b>	<b>124</b>	<b>132</b>	<b>0</b>	<b>4</b>	<b>5</b>	<b>8</b>	<b>17</b>	<b>0</b>	<b>0</b>	<b>282</b>	<b>9</b>	<b>291</b>	<b>0</b>	<b>42</b>	<b>114</b>	<b>0</b>	<b>156</b>	<b>596</b>
05:00 PM	0	2	0	55	57	0	0	2	2	4	0	0	91	3	94	0	9	24	0	33	188
05:15 PM	0	1	0	64	65	0	1	0	1	2	0	0	94	0	94	0	12	30	0	42	203
05:30 PM	0	2	0	42	44	0	1	2	1	4	0	0	90	1	91	0	8	22	0	30	169
05:45 PM	0	4	0	34	38	0	0	2	3	5	0	0	98	2	100	0	2	33	0	35	178
<b>Total</b>	<b>0</b>	<b>9</b>	<b>0</b>	<b>195</b>	<b>204</b>	<b>0</b>	<b>2</b>	<b>6</b>	<b>7</b>	<b>15</b>	<b>0</b>	<b>0</b>	<b>373</b>	<b>6</b>	<b>379</b>	<b>0</b>	<b>31</b>	<b>109</b>	<b>0</b>	<b>140</b>	<b>738</b>
<b>Grand Total</b>	<b>0</b>	<b>44</b>	<b>0</b>	<b>403</b>	<b>447</b>	<b>0</b>	<b>7</b>	<b>27</b>	<b>35</b>	<b>69</b>	<b>0</b>	<b>0</b>	<b>922</b>	<b>25</b>	<b>947</b>	<b>0</b>	<b>253</b>	<b>709</b>	<b>0</b>	<b>962</b>	<b>2425</b>
Apprch %	0	9.8	0	90.2		0	10.1	39.1	50.7		0	0	97.4	2.6		0	26.3	73.7	0		
Total %	0	1.8	0	16.6	18.4	0	0.3	1.1	1.4	2.8	0	0	38	1	39.1	0	10.4	29.2	0	39.7	
Vehicle	0	43	0	402	445	0	7	27	35	69	0	0	917	25	942	0	252	705	0	957	2413
% Vehicle	0	97.7	0	99.8	99.6	0	100	100	100	100	0	0	99.5	100	99.5	0	99.6	99.4	0	99.5	99.5
Trucks	0	1	0	1	2	0	0	0	0	0	0	0	5	0	5	0	1	4	0	5	12
% Trucks	0	2.3	0	0.2	0.4	0	0	0	0	0	0	0	0.5	0	0.5	0	0.4	0.6	0	0.5	0.5

# University Dr at Salzedo Street

File Name : TMC-1 University Dr at Salzedo Street  
 Site Code : 00000000  
 Start Date : 8/31/2021  
 Page No : 2



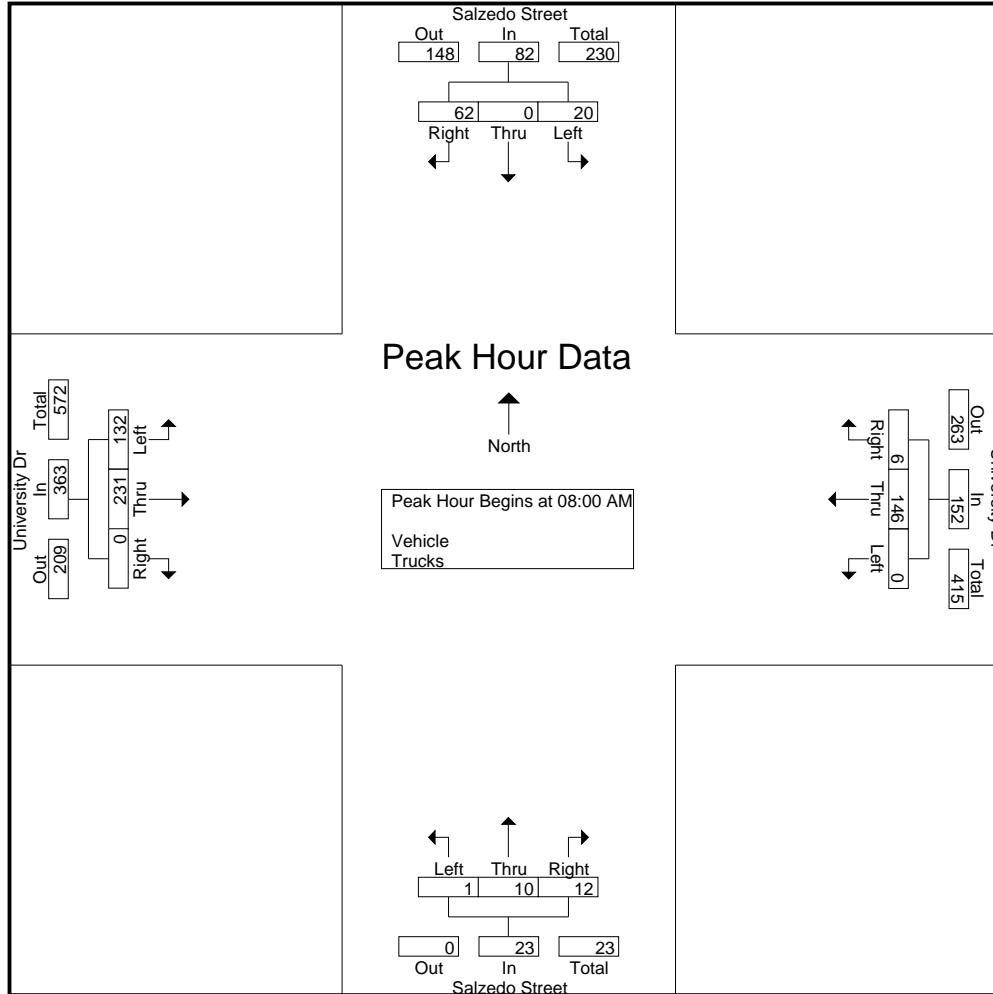
# University Dr at Salzedo Street

File Name : TMC-1 University Dr at Salzedo Street  
 Site Code : 00000000  
 Start Date : 8/31/2021  
 Page No : 3

Start Time	Salzedo Street Southbound					Salzedo Street Northbound					University Dr Westbound					University Dr Eastbound					Int. Total
	U-Turns	Left	Thru	Right	App. Total	U-Turns	Left	Thru	Right	App. Total	U-Turns	Left	Thru	Right	App. Total	U-Turns	Left	Thru	Right	App. Total	
Peak Hour Analysis From 07:00 AM to 08:45 AM - Peak 1 of 1																					
Peak Hour for Entire Intersection Begins at 08:00 AM																					
08:00 AM	0	4	0	13	17	0	1	2	3	6	0	0	43	2	45	0	23	52	0	75	143
08:15 AM	0	8	0	13	21	0	0	0	3	3	0	0	35	1	36	0	27	67	0	94	154
08:30 AM	0	6	0	20	26	0	0	2	5	7	0	0	43	2	45	0	27	50	0	77	155
08:45 AM	0	2	0	16	18	0	0	6	1	7	0	0	25	1	26	0	55	62	0	117	168
Total Volume	0	20	0	62	82	0	1	10	12	23	0	0	146	6	152	0	132	231	0	363	620
% App. Total	0	24.4	0	75.6		0	4.3	43.5	52.2		0	0	96.1	3.9		0	36.4	63.6	0		
PHF	.000	.625	.000	.775	.788	.000	.250	.417	.600	.821	.000	.000	.849	.750	.844	.000	.600	.862	.000	.776	.923

# University Dr at Salzedo Street

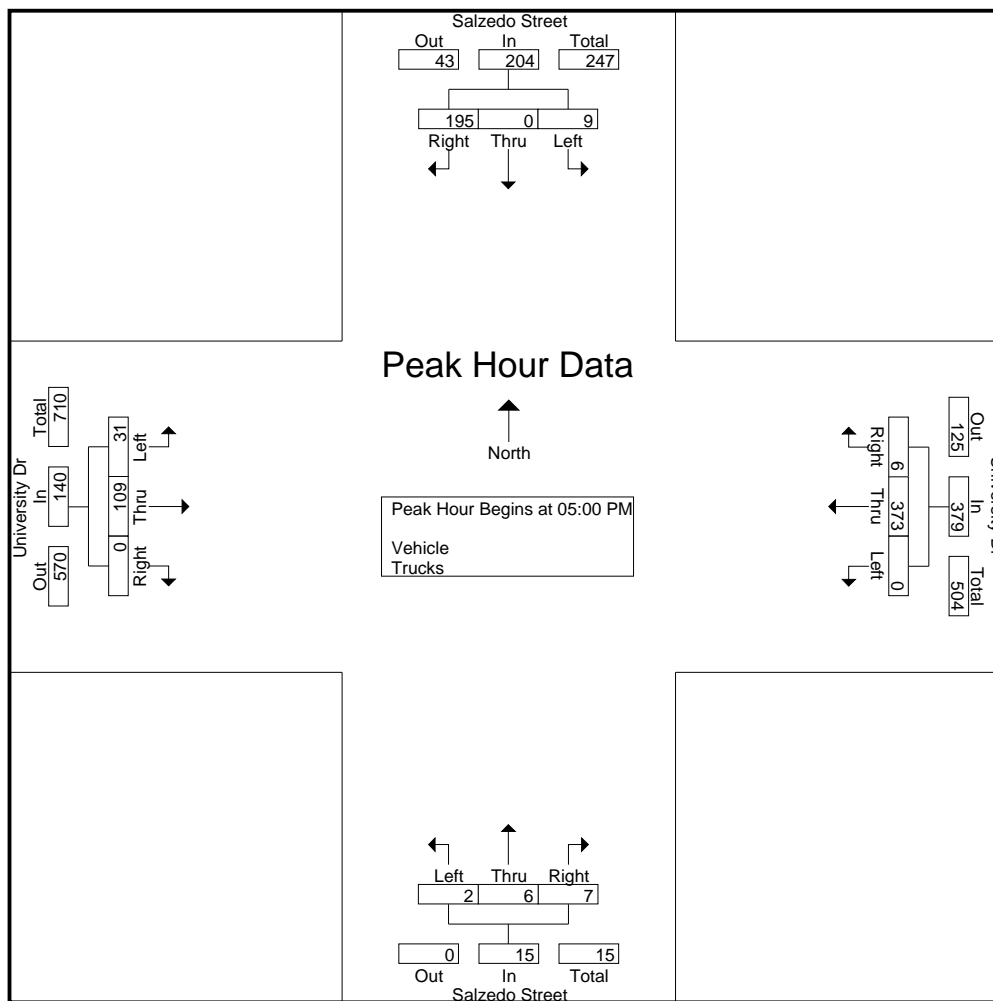
File Name : TMC-1 University Dr at Salzedo Street  
 Site Code : 00000000  
 Start Date : 8/31/2021  
 Page No : 4



# University Dr at Salzedo Street

File Name : TMC-1 University Dr at Salzedo Street  
 Site Code : 00000000  
 Start Date : 8/31/2021  
 Page No : 5

Start Time	Salzedo Street Southbound					Salzedo Street Northbound					University Dr Westbound					University Dr Eastbound					Int. Total
	U-Turns	Left	Thru	Right	App. Total	U-Turns	Left	Thru	Right	App. Total	U-Turns	Left	Thru	Right	App. Total	U-Turns	Left	Thru	Right	App. Total	
Peak Hour Analysis From 04:00 PM to 05:45 PM - Peak 1 of 1																					
Peak Hour for Entire Intersection Begins at 05:00 PM																					
05:00 PM	0	2	0	55	57	0	0	2	2	4	0	0	91	3	94	0	9	24	0	33	188
05:15 PM	0	1	0	<b>64</b>	<b>65</b>	0	<b>1</b>	0	1	2	0	0	94	0	94	0	<b>12</b>	30	0	<b>42</b>	<b>203</b>
05:30 PM	0	2	0	42	44	0	1	2	1	4	0	0	90	1	91	0	8	22	0	30	169
05:45 PM	0	<b>4</b>	0	34	38	0	0	2	<b>3</b>	<b>5</b>	0	0	<b>98</b>	2	<b>100</b>	0	2	<b>33</b>	0	35	178
Total Volume	0	9	0	195	204	0	2	6	7	15	0	0	373	6	379	0	31	109	0	140	738
% App. Total	0	4.4	0	95.6		0	13.3	40	46.7		0	0	98.4	1.6		0	22.1	77.9	0		
PHF	.000	.563	.000	.762	.785	.000	.500	.750	.583	.750	.000	.000	.952	.500	.948	.000	.646	.826	.000	.833	.909



# University Dr at Salzedo Street

File Name : TMC-1 University Dr at Salzedo Street  
 Site Code : 00000000  
 Start Date : 8/31/2021  
 Page No : 1

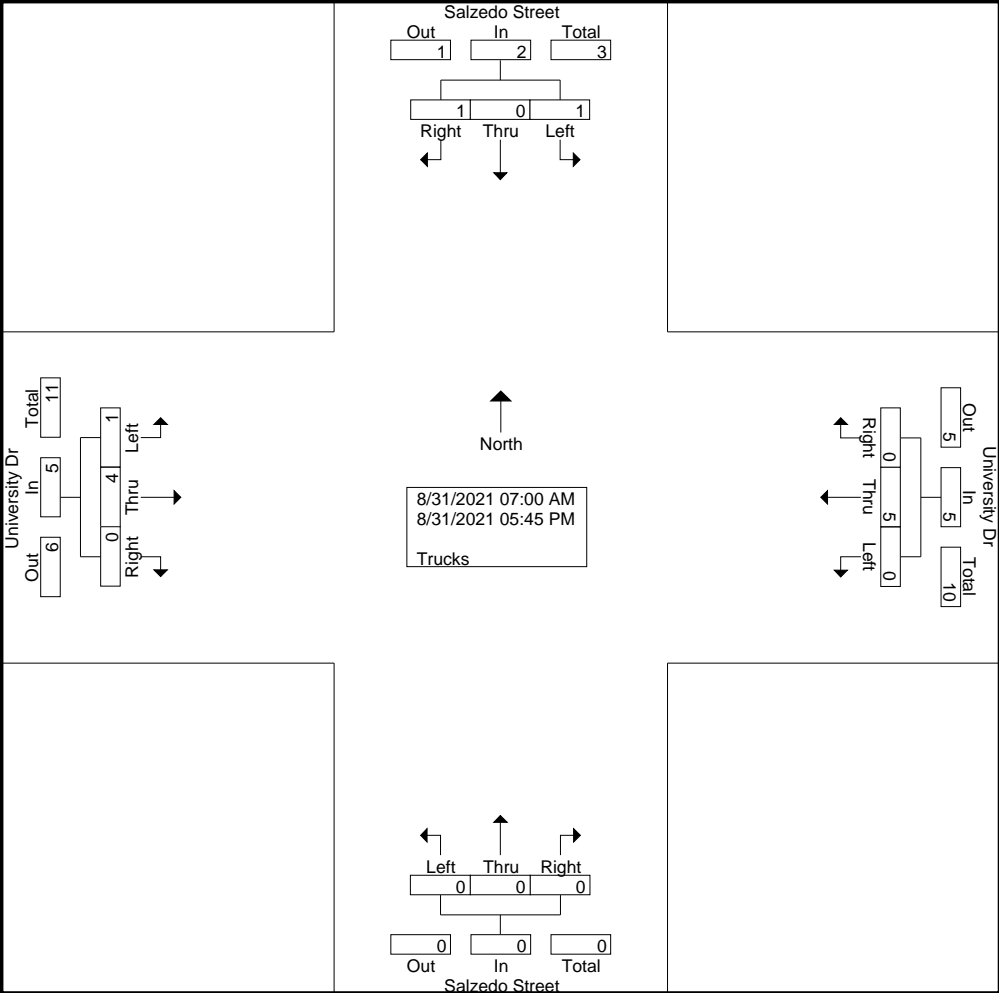
## Groups Printed- Trucks

Start Time	Salzedo Street Southbound					Salzedo Street Northbound					University Dr Westbound					University Dr Eastbound					Int. Total
	U-Turns	Left	Thru	Right	App. Total	U-Turns	Left	Thru	Right	App. Total	U-Turns	Left	Thru	Right	App. Total	U-Turns	Left	Thru	Right	App. Total	
*** BREAK ***																					
07:45 AM	0	1	0	0	1	0	0	0	0	0	0	0	0	0	0	0	0	0	0	0	0
Total	0	1	0	0	1	0	0	0	0	0	0	0	0	0	0	0	0	0	0	0	0
08:00 AM	0	0	0	0	0	0	0	0	0	0	0	0	2	0	2	0	0	0	0	0	0
08:15 AM	0	0	0	1	1	0	0	0	0	0	0	0	0	0	0	0	0	1	0	1	2
*** BREAK ***																					
08:45 AM	0	0	0	0	0	0	0	0	0	0	0	0	1	0	1	0	1	0	0	1	2
Total	0	0	0	1	1	0	0	0	0	0	0	0	3	0	3	0	1	1	0	2	6
*** BREAK ***																					
04:00 PM	0	0	0	0	0	0	0	0	0	0	0	0	0	0	0	0	0	1	0	1	1
04:15 PM	0	0	0	0	0	0	0	0	0	0	0	0	0	0	0	0	0	1	0	1	1
04:30 PM	0	0	0	0	0	0	0	0	0	0	0	0	0	0	0	0	0	1	0	1	1
*** BREAK ***																					
Total	0	0	0	0	0	0	0	0	0	0	0	0	0	0	0	0	0	3	0	3	3
05:00 PM	0	0	0	0	0	0	0	0	0	0	0	0	2	0	2	0	0	0	0	0	2
*** BREAK ***																					
Total	0	0	0	0	0	0	0	0	0	0	0	0	2	0	2	0	0	0	0	0	2
Grand Total	0	1	0	1	2	0	0	0	0	0	0	0	5	0	5	0	1	4	0	5	12
Apprch %	0	50	0	50		0	0	0	0		0	0	100	0		0	20	80	0		
Total %	0	8.3	0	8.3	16.7	0	0	0	0	0	0	0	41.7	0	41.7	0	8.3	33.3	0	41.7	



# University Dr at Salzedo Street

File Name : TMC-1 University Dr at Salzedo Street  
 Site Code : 00000000  
 Start Date : 8/31/2021  
 Page No : 2



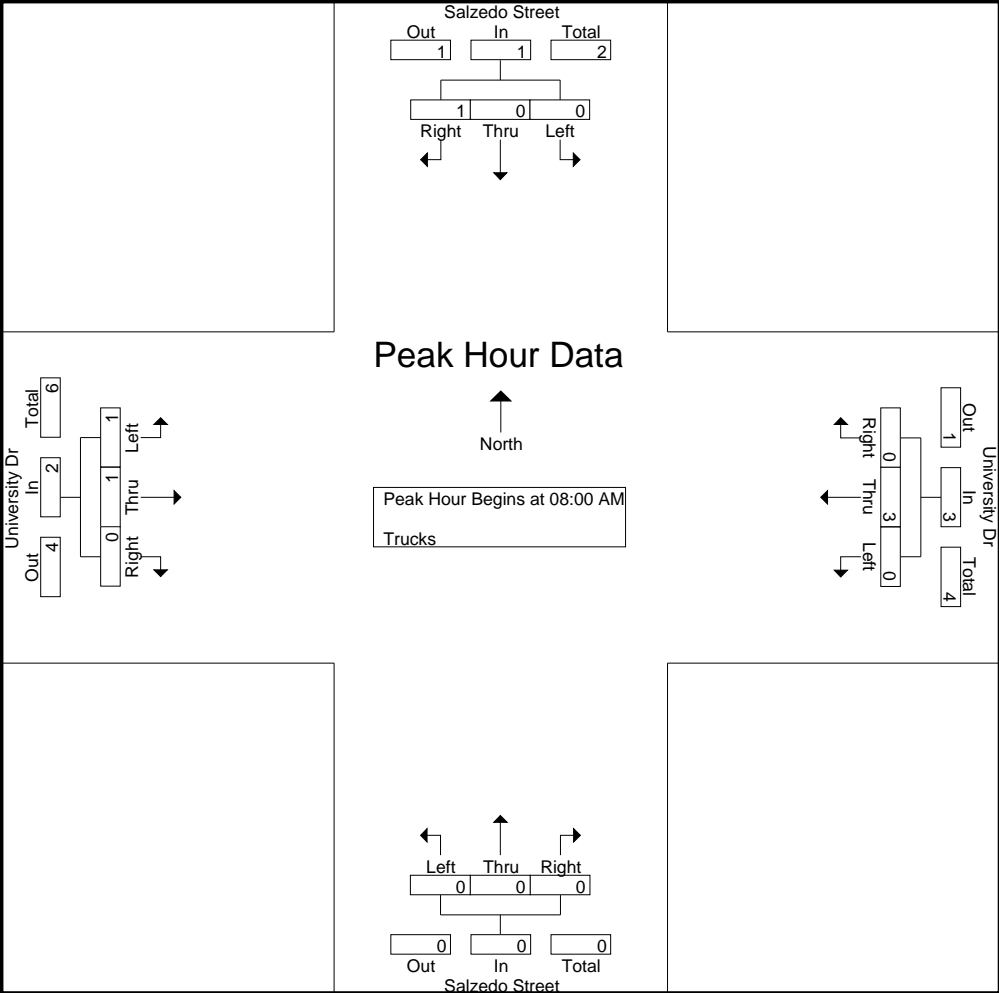
# University Dr at Salzedo Street

File Name : TMC-1 University Dr at Salzedo Street  
 Site Code : 00000000  
 Start Date : 8/31/2021  
 Page No : 3

Start Time	Salzedo Street Southbound					Salzedo Street Northbound					University Dr Westbound					University Dr Eastbound					Int. Total
	U-Turns	Left	Thru	Right	App. Total	U-Turns	Left	Thru	Right	App. Total	U-Turns	Left	Thru	Right	App. Total	U-Turns	Left	Thru	Right	App. Total	
Peak Hour Analysis From 07:00 AM to 08:45 AM - Peak 1 of 1																					
Peak Hour for Entire Intersection Begins at 08:00 AM																					
08:00 AM	0	0	0	0	0	0	0	0	0	0	0	0	2	0	2	0	0	0	0	0	2
08:15 AM	0	0	0	1	1	0	0	0	0	0	0	0	0	0	0	0	0	1	0	1	2
08:30 AM	0	0	0	0	0	0	0	0	0	0	0	0	0	0	0	0	0	0	0	0	0
08:45 AM	0	0	0	0	0	0	0	0	0	0	0	0	1	0	1	0	1	0	0	1	2
Total Volume	0	0	0	1	1	0	0	0	0	0	0	0	3	0	3	0	1	1	0	2	6
% App. Total	0	0	0	100		0	0	0	0		0	0	100	0		0	50	50	0		
PHF	.000	.000	.000	.250	.250	.000	.000	.000	.000	.000	.000	.000	.375	.000	.375	.000	.250	.250	.000	.500	.750

# University Dr at Salzedo Street

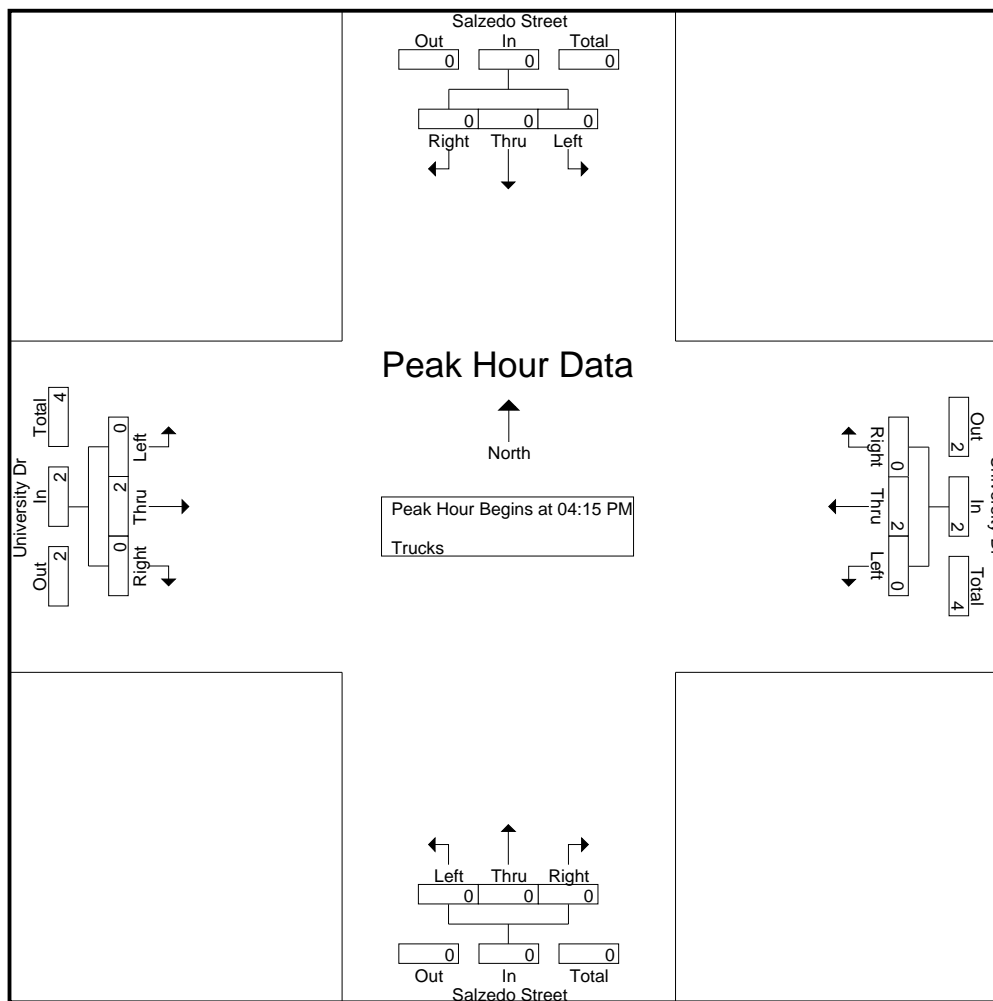
File Name : TMC-1 University Dr at Salzedo Street  
 Site Code : 00000000  
 Start Date : 8/31/2021  
 Page No : 4



# University Dr at Salzedo Street

File Name : TMC-1 University Dr at Salzedo Street  
 Site Code : 00000000  
 Start Date : 8/31/2021  
 Page No : 5

Start Time	Salzedo Street Southbound					Salzedo Street Northbound					University Dr Westbound					University Dr Eastbound					Int. Total
	U-Turns	Left	Thru	Right	App. Total	U-Turns	Left	Thru	Right	App. Total	U-Turns	Left	Thru	Right	App. Total	U-Turns	Left	Thru	Right	App. Total	
Peak Hour Analysis From 04:00 PM to 05:45 PM - Peak 1 of 1																					
Peak Hour for Entire Intersection Begins at 04:15 PM																					
04:15 PM	0	0	0	0	0	0	0	0	0	0	0	0	0	0	0	0	0	1	0	1	1
04:30 PM	0	0	0	0	0	0	0	0	0	0	0	0	0	0	0	0	0	1	0	1	1
04:45 PM	0	0	0	0	0	0	0	0	0	0	0	0	0	0	0	0	0	0	0	0	0
05:00 PM	0	0	0	0	0	0	0	0	0	0	0	0	2	0	2	0	0	0	0	0	2
Total Volume	0	0	0	0	0	0	0	0	0	0	0	0	2	0	2	0	0	2	0	2	4
% App. Total	0	0	0	0	0	0	0	0	0	0	0	0	100	0	250	0	0	100	0	500	500
PHF	.000	.000	.000	.000	.000	.000	.000	.000	.000	.000	.000	.000	.250	.000	.250	.000	.000	.500	.000	.500	.500



# University Dr at Salzedo Street

File Name : TMC-1 University Dr at Salzedo Street  
 Site Code : 00000000  
 Start Date : 8/31/2021  
 Page No : 1

### Groups Printed- Peds & Bikes

Start Time	Salzedo Street Southbound			Salzedo Street Northbound			University Dr Westbound			University Dr Eastbound			Int. Total
	Peds	Bikes	App. Total	Peds	Bikes	App. Total	Peds	Bikes	App. Total	Peds	Bikes	App. Total	
07:00 AM	0	0	0	1	0	1	1	0	1	0	0	0	2
07:15 AM	0	0	0	2	0	2	1	0	1	2	0	2	5
07:30 AM	3	0	3	1	0	1	4	0	4	1	0	1	9
07:45 AM	3	0	3	3	0	3	0	0	0	1	0	1	7
<b>Total</b>	<b>6</b>	<b>0</b>	<b>6</b>	<b>7</b>	<b>0</b>	<b>7</b>	<b>6</b>	<b>0</b>	<b>6</b>	<b>4</b>	<b>0</b>	<b>4</b>	<b>23</b>
08:00 AM	0	0	0	0	0	0	0	0	0	2	0	2	2
08:15 AM	0	0	0	1	0	1	1	1	2	0	0	0	3
08:30 AM	0	0	0	0	0	0	1	0	1	0	0	0	1
08:45 AM	1	0	1	3	2	5	1	0	1	2	0	2	9
<b>Total</b>	<b>1</b>	<b>0</b>	<b>1</b>	<b>4</b>	<b>2</b>	<b>6</b>	<b>3</b>	<b>1</b>	<b>4</b>	<b>4</b>	<b>0</b>	<b>4</b>	<b>15</b>
<b>*** BREAK ***</b>													
04:00 PM	0	0	0	1	0	1	0	0	0	0	0	0	1
04:15 PM	0	0	0	1	0	1	0	1	1	0	0	0	2
04:30 PM	0	0	0	0	0	0	1	0	1	0	0	0	1
04:45 PM	0	0	0	1	0	1	0	0	0	0	0	0	1
<b>Total</b>	<b>0</b>	<b>0</b>	<b>0</b>	<b>3</b>	<b>0</b>	<b>3</b>	<b>1</b>	<b>1</b>	<b>2</b>	<b>0</b>	<b>0</b>	<b>0</b>	<b>5</b>
05:00 PM	2	0	2	1	0	1	1	0	1	1	0	1	5
05:15 PM	2	1	3	1	0	1	0	0	0	5	0	5	9
05:30 PM	0	0	0	2	0	2	0	2	2	2	0	2	6
05:45 PM	5	0	5	2	0	2	3	0	3	0	0	0	10
<b>Total</b>	<b>9</b>	<b>1</b>	<b>10</b>	<b>6</b>	<b>0</b>	<b>6</b>	<b>4</b>	<b>2</b>	<b>6</b>	<b>8</b>	<b>0</b>	<b>8</b>	<b>30</b>
<b>Grand Total</b>	<b>16</b>	<b>1</b>	<b>17</b>	<b>20</b>	<b>2</b>	<b>22</b>	<b>14</b>	<b>4</b>	<b>18</b>	<b>16</b>	<b>0</b>	<b>16</b>	<b>73</b>
Apprch %	94.1	5.9		90.9	9.1		77.8	22.2		100	0		
Total %	21.9	1.4	23.3	27.4	2.7	30.1	19.2	5.5	24.7	21.9	0	21.9	

# University Dr at Salzedo Street

File Name : TMC-1 University Dr at Salzedo Street  
 Site Code : 00000000  
 Start Date : 8/31/2021  
 Page No : 3

Start Time	Salzedo Street Southbound			Salzedo Street Northbound			University Dr Westbound			University Dr Eastbound			Int. Total
	Peds	Bikes	App. Total	Peds	Bikes	App. Total	Peds	Bikes	App. Total	Peds	Bikes	App. Total	
Peak Hour Analysis From 07:00 AM to 08:45 AM - Peak 1 of 1													
Peak Hour for Entire Intersection Begins at 07:00 AM													
07:00 AM	0	0	0	1	0	1	1	0	1	0	0	0	2
07:15 AM	0	0	0	2	0	2	1	0	1	2	0	2	5
07:30 AM	3	0	3	1	0	1	4	0	4	1	0	1	9
07:45 AM	3	0	3	3	0	3	0	0	0	1	0	1	7
Total Volume	6	0	6	7	0	7	6	0	6	4	0	4	23
% App. Total	100	0		100	0		100	0		100	0		
PHF	.500	.000	.500	.583	.000	.583	.375	.000	.375	.500	.000	.500	.639

# University Dr at Salzedo Street

File Name : TMC-1 University Dr at Salzedo Street

Site Code : 00000000

Start Date : 8/31/2021

Page No : 5

Start Time	Salzedo Street Southbound			Salzedo Street Northbound			University Dr Westbound			University Dr Eastbound			Int. Total
	Peds	Bikes	App. Total	Peds	Bikes	App. Total	Peds	Bikes	App. Total	Peds	Bikes	App. Total	
Peak Hour Analysis From 04:00 PM to 05:45 PM - Peak 1 of 1													
Peak Hour for Entire Intersection Begins at 05:00 PM													
05:00 PM	2	0	2	1	0	1	1	0	1	1	0	1	5
05:15 PM	2	1	3	1	0	1	0	0	0	5	0	5	9
05:30 PM	0	0	0	2	0	2	0	2	2	2	0	2	6
05:45 PM	5	0	5	2	0	2	3	0	3	0	0	0	10
Total Volume	9	1	10	6	0	6	4	2	6	8	0	8	30
% App. Total	90	10		100	0		66.7	33.3		100	0		
PHF	.450	.250	.500	.750	.000	.750	.333	.250	.500	.400	.000	.400	.750

# Malaga Avenue at Salzedo Street

File Name : TMC-2 Malaga Avenue at Salzedo Street

Site Code : 00000000

Start Date : 8/31/2021

Page No : 1

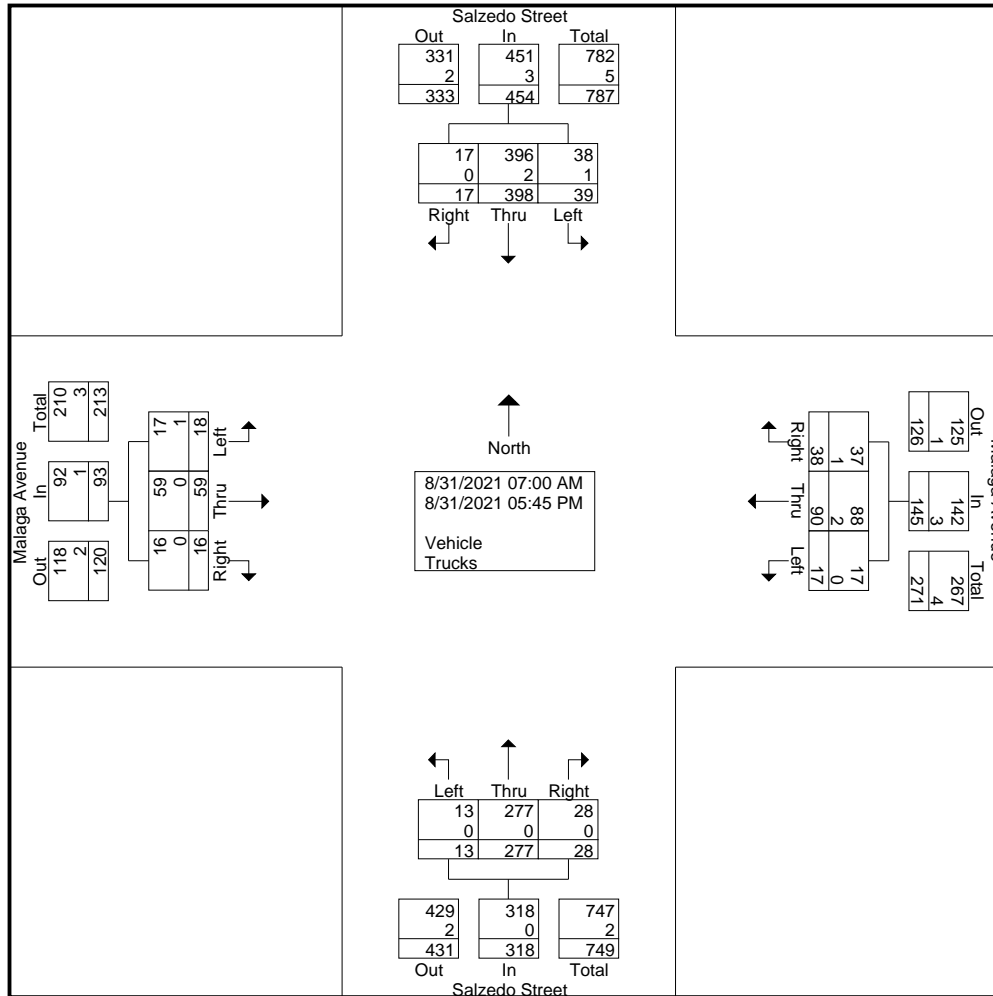
## Groups Printed- Vehicle - Trucks

Start Time	Salzedo Street Southbound					Salzedo Street Northbound					Malaga Avenue Westbound					Malaga Avenue Eastbound					Int. Total
	U-Turns	Left	Thru	Right	App. Total	U-Turns	Left	Thru	Right	App. Total	U-Turns	Left	Thru	Right	App. Total	U-Turns	Left	Thru	Right	App. Total	
07:00 AM	0	1	5	0	6	0	0	10	1	11	0	0	3	2	5	0	0	5	1	6	28
07:15 AM	0	0	3	0	3	0	0	14	0	14	0	0	3	0	3	0	0	3	1	4	24
07:30 AM	0	3	7	0	10	0	0	9	2	11	0	1	3	1	5	0	0	2	0	2	28
07:45 AM	0	4	10	0	14	0	0	24	1	25	0	1	2	2	5	0	3	4	0	7	51
<b>Total</b>	<b>0</b>	<b>8</b>	<b>25</b>	<b>0</b>	<b>33</b>	<b>0</b>	<b>0</b>	<b>57</b>	<b>4</b>	<b>61</b>	<b>0</b>	<b>2</b>	<b>11</b>	<b>5</b>	<b>18</b>	<b>0</b>	<b>3</b>	<b>14</b>	<b>2</b>	<b>19</b>	<b>131</b>
08:00 AM	0	0	17	0	17	0	1	28	1	30	0	0	4	4	8	0	2	4	2	8	63
08:15 AM	0	4	17	2	23	1	0	30	1	32	0	1	3	4	8	0	3	6	0	9	72
08:30 AM	0	4	27	1	32	0	0	29	3	32	0	1	5	6	12	0	0	7	0	7	83
08:45 AM	0	2	16	1	19	0	1	53	4	58	0	0	2	2	4	0	3	9	1	13	94
<b>Total</b>	<b>0</b>	<b>10</b>	<b>77</b>	<b>4</b>	<b>91</b>	<b>1</b>	<b>2</b>	<b>140</b>	<b>9</b>	<b>152</b>	<b>0</b>	<b>2</b>	<b>14</b>	<b>16</b>	<b>32</b>	<b>0</b>	<b>8</b>	<b>26</b>	<b>3</b>	<b>37</b>	<b>312</b>
*** BREAK ***																					
04:00 PM	1	2	20	1	24	1	0	9	1	11	0	3	7	1	11	0	1	1	1	3	49
04:15 PM	0	1	28	0	29	1	1	12	1	15	0	1	6	1	8	0	1	3	2	6	58
04:30 PM	0	3	35	2	40	0	1	17	5	23	1	1	7	2	11	0	0	3	0	3	77
04:45 PM	1	2	30	4	37	0	1	7	1	9	0	1	5	4	10	0	3	5	2	10	66
<b>Total</b>	<b>2</b>	<b>8</b>	<b>113</b>	<b>7</b>	<b>130</b>	<b>2</b>	<b>3</b>	<b>45</b>	<b>8</b>	<b>58</b>	<b>1</b>	<b>6</b>	<b>25</b>	<b>8</b>	<b>40</b>	<b>0</b>	<b>5</b>	<b>12</b>	<b>5</b>	<b>22</b>	<b>250</b>
05:00 PM	0	3	48	1	52	3	1	9	2	15	0	2	9	2	13	0	1	2	0	3	83
05:15 PM	0	4	59	4	67	0	0	11	4	15	0	3	13	3	19	0	1	1	1	3	104
05:30 PM	0	2	37	1	40	0	1	12	0	13	0	0	11	2	13	0	0	3	3	6	72
05:45 PM	0	2	39	0	41	0	0	3	1	4	0	1	7	2	10	0	0	1	2	3	58
<b>Total</b>	<b>0</b>	<b>11</b>	<b>183</b>	<b>6</b>	<b>200</b>	<b>3</b>	<b>2</b>	<b>35</b>	<b>7</b>	<b>47</b>	<b>0</b>	<b>6</b>	<b>40</b>	<b>9</b>	<b>55</b>	<b>0</b>	<b>2</b>	<b>7</b>	<b>6</b>	<b>15</b>	<b>317</b>
<b>Grand Total</b>	<b>2</b>	<b>37</b>	<b>398</b>	<b>17</b>	<b>454</b>	<b>6</b>	<b>7</b>	<b>277</b>	<b>28</b>	<b>318</b>	<b>1</b>	<b>16</b>	<b>90</b>	<b>38</b>	<b>145</b>	<b>0</b>	<b>18</b>	<b>59</b>	<b>16</b>	<b>93</b>	<b>1010</b>
Apprch %	0.4	8.1	87.7	3.7		1.9	2.2	87.1	8.8		0.7	11	62.1	26.2		0	19.4	63.4	17.2		
Total %	0.2	3.7	39.4	1.7	45	0.6	0.7	27.4	2.8	31.5	0.1	1.6	8.9	3.8	14.4	0	1.8	5.8	1.6	9.2	
Vehicle	2	36	396	17	451	6	7	277	28	318	1	16	88	37	142	0	17	59	16	92	1003
% Vehicle	100	97.3	99.5	100	99.3	100	100	100	100	100	100	100	97.8	97.4	97.9	0	94.4	100	100	98.9	99.3
Trucks	0	1	2	0	3	0	0	0	0	0	0	0	2	1	3	0	1	0	0	1	7
% Trucks	0	2.7	0.5	0	0.7	0	0	0	0	0	0	0	2.2	2.6	2.1	0	5.6	0	0	1.1	0.7



# Malaga Avenue at Salzedo Street

File Name : TMC-2 Malaga Avenue at Salzedo Street  
 Site Code : 00000000  
 Start Date : 8/31/2021  
 Page No : 2



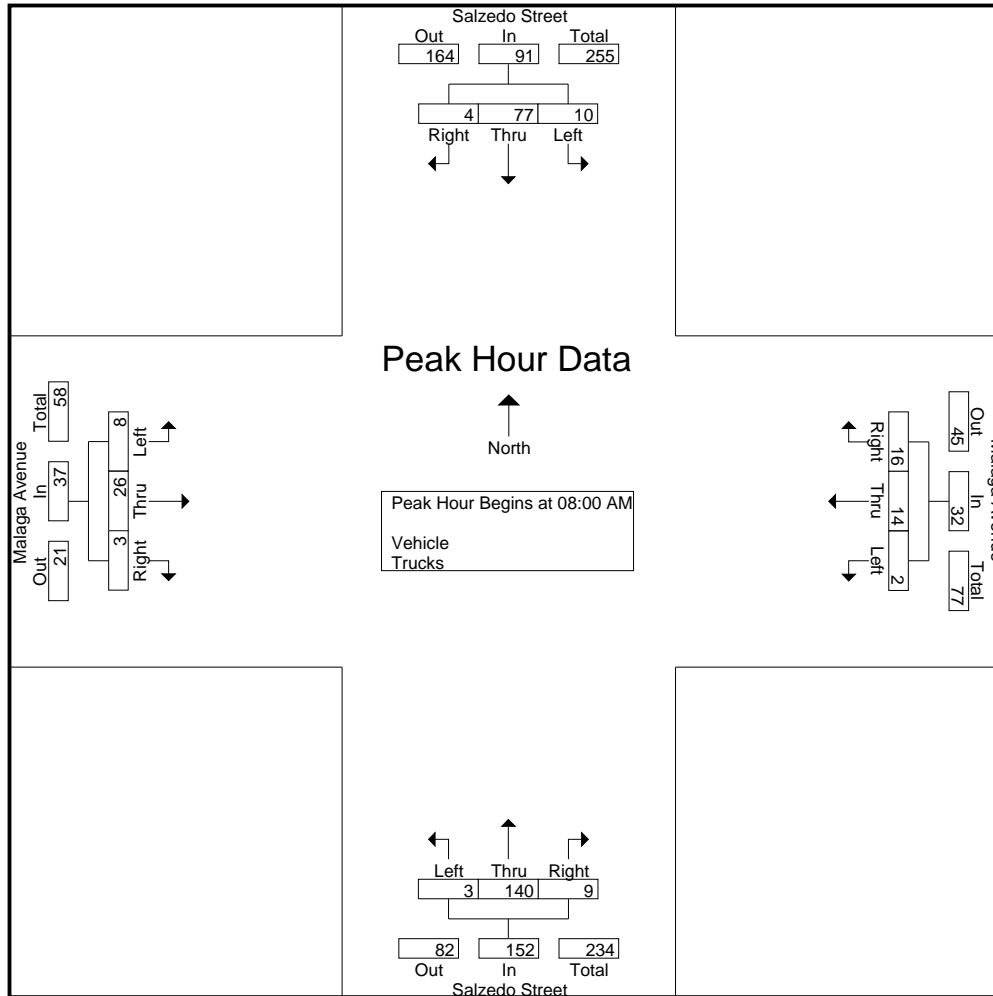
# Malaga Avenue at Salzedo Street

File Name : TMC-2 Malaga Avenue at Salzedo Street  
 Site Code : 00000000  
 Start Date : 8/31/2021  
 Page No : 3

Start Time	Salzedo Street Southbound					Salzedo Street Northbound					Malaga Avenue Westbound					Malaga Avenue Eastbound					Int. Total
	U-Turns	Left	Thru	Right	App. Total	U-Turns	Left	Thru	Right	App. Total	U-Turns	Left	Thru	Right	App. Total	U-Turns	Left	Thru	Right	App. Total	
Peak Hour Analysis From 07:00 AM to 08:45 AM - Peak 1 of 1																					
Peak Hour for Entire Intersection Begins at 08:00 AM																					
08:00 AM	0	0	17	0	17	0	1	28	1	30	0	0	4	4	8	0	2	4	2	8	63
08:15 AM	0	4	17	2	23	1	0	30	1	32	0	1	3	4	8	0	3	6	0	9	72
08:30 AM	0	4	27	1	32	0	0	29	3	32	0	1	5	6	12	0	0	7	0	7	83
08:45 AM	0	2	16	1	19	0	1	53	4	58	0	0	2	2	4	0	3	9	1	13	94
Total Volume	0	10	77	4	91	1	2	140	9	152	0	2	14	16	32	0	8	26	3	37	312
% App. Total	0	11	84.6	4.4		0.7	1.3	92.1	5.9		0	6.2	43.8	50		0	21.6	70.3	8.1		
PHF	.000	.625	.713	.500	.711	.250	.500	.660	.563	.655	.000	.500	.700	.667	.667	.000	.667	.722	.375	.712	.830

# Malaga Avenue at Salzedo Street

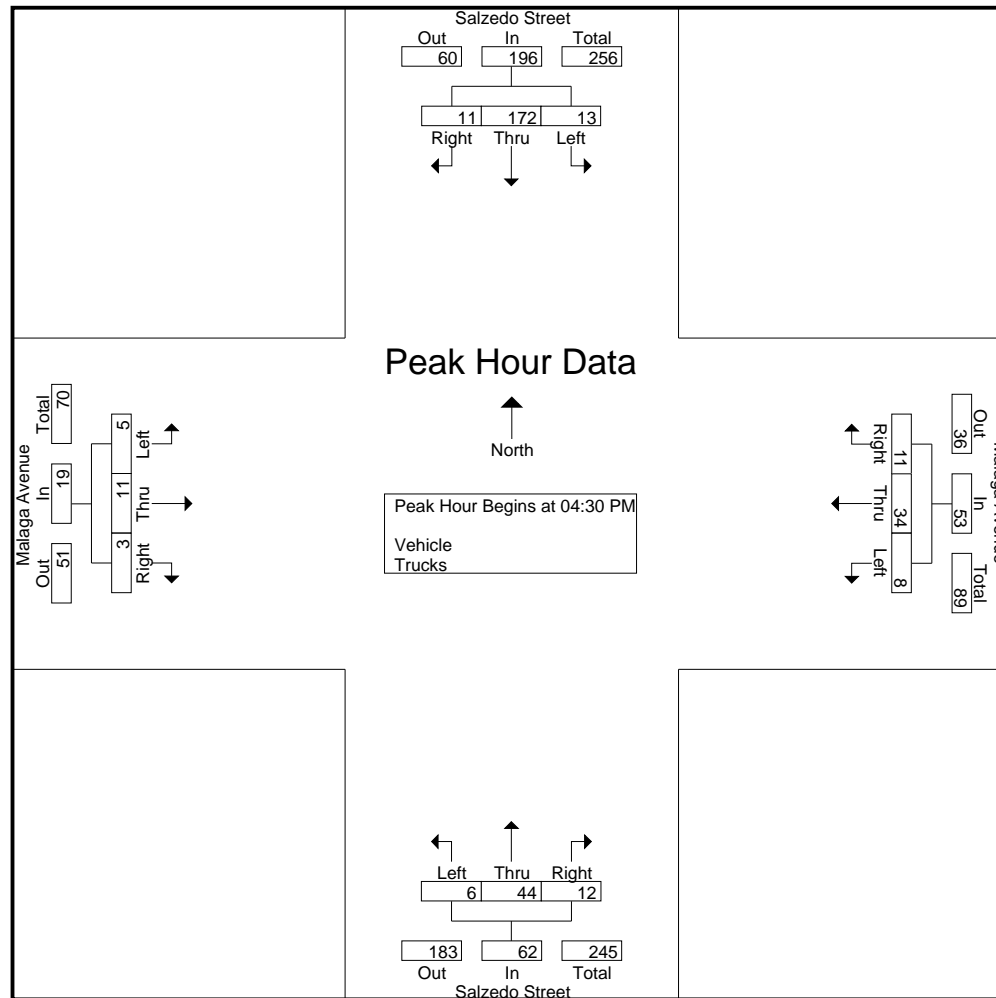
File Name : TMC-2 Malaga Avenue at Salzedo Street  
 Site Code : 00000000  
 Start Date : 8/31/2021  
 Page No : 4



# Malaga Avenue at Salzedo Street

File Name : TMC-2 Malaga Avenue at Salzedo Street  
 Site Code : 00000000  
 Start Date : 8/31/2021  
 Page No : 5

Start Time	Salzedo Street Southbound					Salzedo Street Northbound					Malaga Avenue Westbound					Malaga Avenue Eastbound					Int. Total
	U-Turns	Left	Thru	Right	App. Total	U-Turns	Left	Thru	Right	App. Total	U-Turns	Left	Thru	Right	App. Total	U-Turns	Left	Thru	Right	App. Total	
Peak Hour Analysis From 04:00 PM to 05:45 PM - Peak 1 of 1																					
Peak Hour for Entire Intersection Begins at 04:30 PM																					
04:30 PM	0	3	35	2	40	0	1	17	5	23	1	1	7	2	11	0	0	3	0	3	77
04:45 PM	1	2	30	4	37	0	1	7	1	9	0	1	5	4	10	0	3	5	2	10	66
05:00 PM	0	3	48	1	52	3	1	9	2	15	0	2	9	2	13	0	1	2	0	3	83
05:15 PM	0	4	59	4	67	0	0	11	4	15	0	3	13	3	19	0	1	1	1	3	104
Total Volume	1	12	172	11	196	3	3	44	12	62	1	7	34	11	53	0	5	11	3	19	330
% App. Total	0.5	6.1	87.8	5.6		4.8	4.8	71	19.4		1.9	13.2	64.2	20.8		0	26.3	57.9	15.8		
PHF	.250	.750	.729	.688	.731	.250	.750	.647	.600	.674	.250	.583	.654	.688	.697	.000	.417	.550	.375	.475	.793



# Malaga Avenue at Salzedo Street

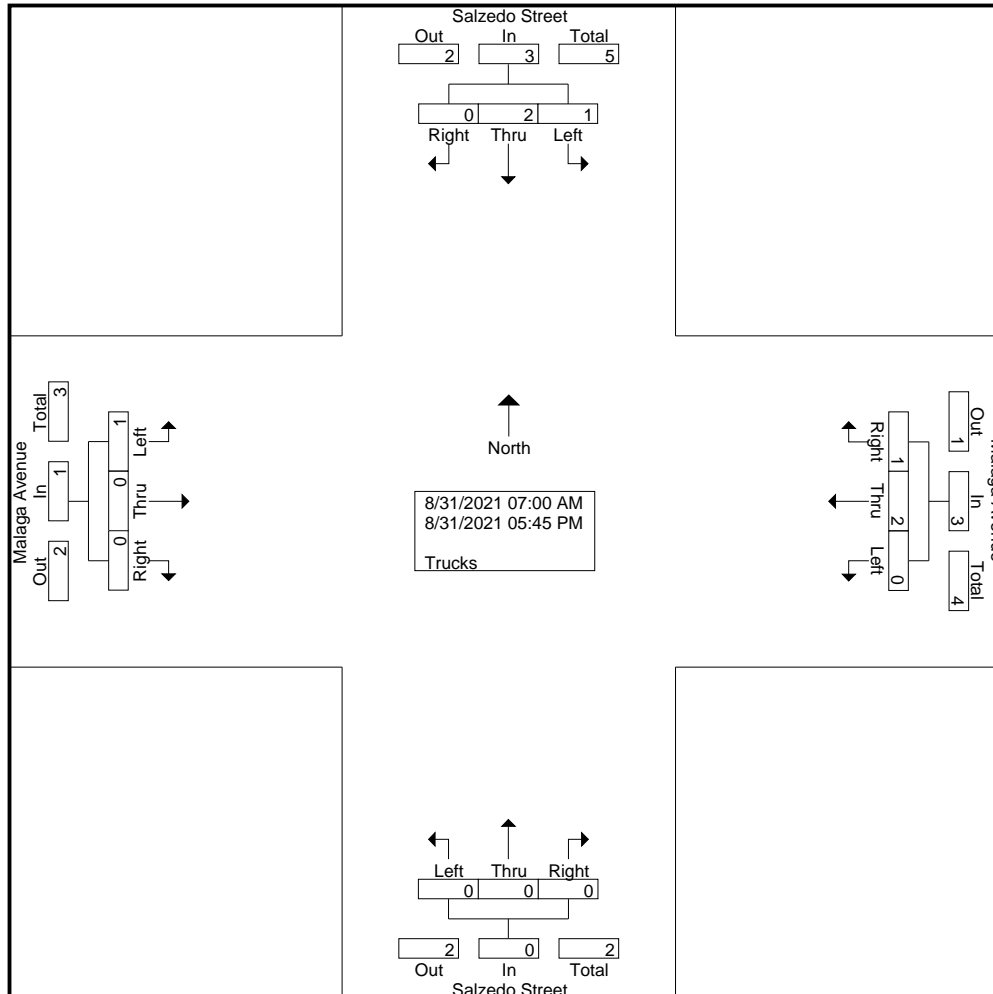
File Name : TMC-2 Malaga Avenue at Salzedo Street  
 Site Code : 00000000  
 Start Date : 8/31/2021  
 Page No : 1

## Groups Printed- Trucks

Start Time	Salzedo Street Southbound					Salzedo Street Northbound					Malaga Avenue Westbound					Malaga Avenue Eastbound					Int. Total	
	U-Turns	Left	Thru	Right	App. Total	U-Turns	Left	Thru	Right	App. Total	U-Turns	Left	Thru	Right	App. Total	U-Turns	Left	Thru	Right	App. Total		
*** BREAK ***																						
07:45 AM	0	0	1	0	1	0	0	0	0	0	0	0	0	0	0	0	0	0	0	0	0	1
Total	0	0	1	0	1	0	0	0	0	0	0	0	0	0	0	0	0	0	0	0	0	1
08:00 AM	0	0	0	0	0	0	0	0	0	0	0	0	1	0	1	0	0	0	0	0	0	1
08:15 AM	0	1	1	0	2	0	0	0	0	0	0	0	1	0	1	0	0	0	0	0	0	3
08:30 AM	0	0	0	0	0	0	0	0	0	0	0	0	0	1	1	0	0	0	0	0	0	1
08:45 AM	0	0	0	0	0	0	0	0	0	0	0	0	0	0	0	0	1	0	0	0	1	1
Total	0	1	1	0	2	0	0	0	0	0	0	0	2	1	3	0	1	0	0	0	1	6
*** BREAK ***																						
Grand Total	0	1	2	0	3	0	0	0	0	0	0	0	2	1	3	0	1	0	0	0	1	7
Apprch %	0	33.3	66.7	0		0	0	0	0		0	0	66.7	33.3		0	100	0	0			
Total %	0	14.3	28.6	0	42.9	0	0	0	0	0	0	0	28.6	14.3	42.9	0	14.3	0	0	14.3		

# Malaga Avenue at Salzedo Street

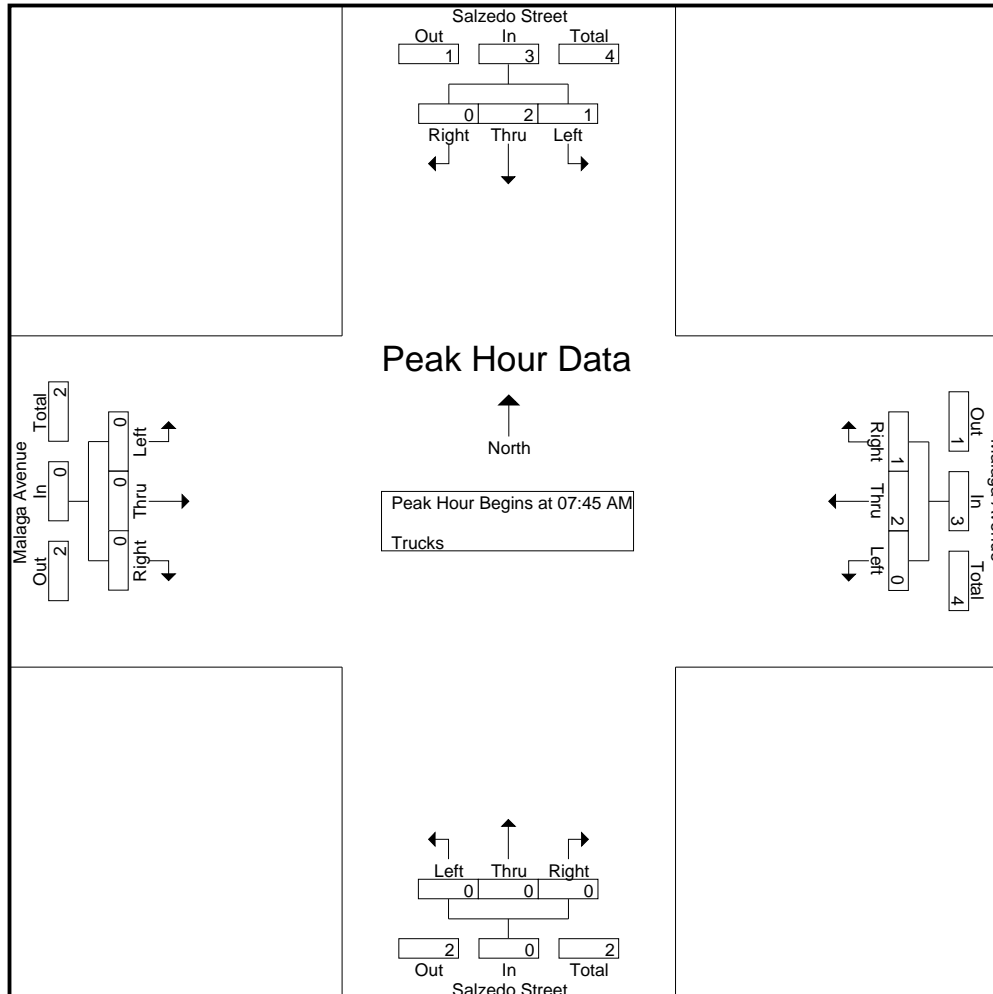
File Name : TMC-2 Malaga Avenue at Salzedo Street  
 Site Code : 00000000  
 Start Date : 8/31/2021  
 Page No : 2





# Malaga Avenue at Salzedo Street

File Name : TMC-2 Malaga Avenue at Salzedo Street  
 Site Code : 00000000  
 Start Date : 8/31/2021  
 Page No : 4

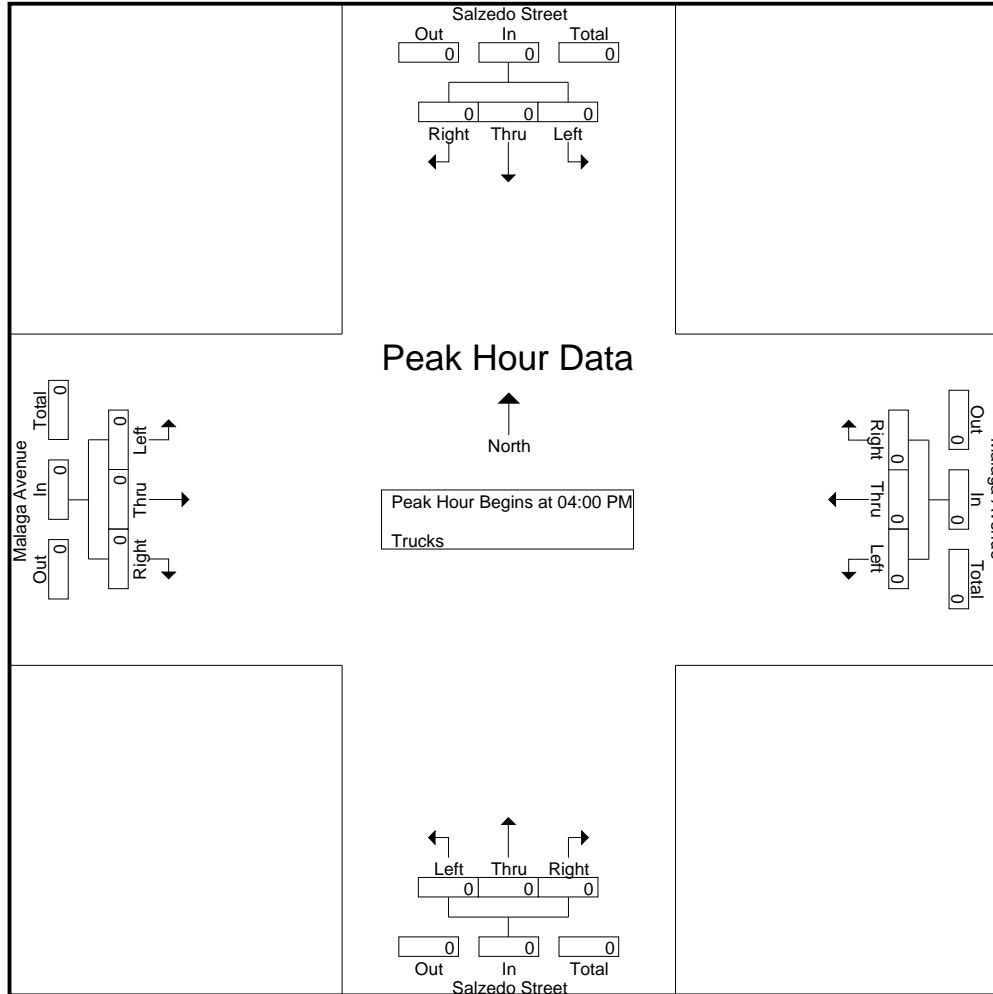




# Malaga Avenue at Salzedo Street

File Name : TMC-2 Malaga Avenue at Salzedo Street  
 Site Code : 00000000  
 Start Date : 8/31/2021  
 Page No : 5

Start Time	Salzedo Street Southbound					Salzedo Street Northbound					Malaga Avenue Westbound					Malaga Avenue Eastbound					Int. Total
	U-Turns	Left	Thru	Right	App. Total	U-Turns	Left	Thru	Right	App. Total	U-Turns	Left	Thru	Right	App. Total	U-Turns	Left	Thru	Right	App. Total	
Peak Hour Analysis From 04:00 PM to 05:45 PM - Peak 1 of 1																					
Peak Hour for Entire Intersection Begins at 04:00 PM																					
04:00 PM	0	0	0	0	0	0	0	0	0	0	0	0	0	0	0	0	0	0	0	0	0
04:15 PM	0	0	0	0	0	0	0	0	0	0	0	0	0	0	0	0	0	0	0	0	0
04:30 PM	0	0	0	0	0	0	0	0	0	0	0	0	0	0	0	0	0	0	0	0	0
04:45 PM	0	0	0	0	0	0	0	0	0	0	0	0	0	0	0	0	0	0	0	0	0
Total Volume	0	0	0	0	0	0	0	0	0	0	0	0	0	0	0	0	0	0	0	0	0
% App. Total	0	0	0	0	0	0	0	0	0	0	0	0	0	0	0	0	0	0	0	0	0
PHF	.000	.000	.000	.000	.000	.000	.000	.000	.000	.000	.000	.000	.000	.000	.000	.000	.000	.000	.000	.000	.000



# Malaga Avenue at Salzedo Street

File Name : TMC-2 Malaga Avenue at Salzedo Street  
 Site Code : 00000000  
 Start Date : 8/31/2021  
 Page No : 1

Groups Printed- Peds & Bikes

Start Time	Salzedo Street Southbound			Salzedo Street Northbound			Malaga Avenue Westbound			Malaga Avenue Eastbound			Int. Total
	Peds	Bikes	App. Total	Peds	Bikes	App. Total	Peds	Bikes	App. Total	Peds	Bikes	App. Total	
07:00 AM	0	0	0	0	0	0	1	0	1	2	0	2	3
07:15 AM	0	0	0	0	0	0	0	0	0	2	0	2	2
07:30 AM	1	0	1	1	0	1	1	0	1	2	0	2	5
07:45 AM	1	0	1	0	0	0	0	0	0	2	0	2	3
<b>Total</b>	<b>2</b>	<b>0</b>	<b>2</b>	<b>1</b>	<b>0</b>	<b>1</b>	<b>2</b>	<b>0</b>	<b>2</b>	<b>8</b>	<b>0</b>	<b>8</b>	<b>13</b>
*** BREAK ***													
08:15 AM	0	0	0	0	0	0	1	0	1	2	1	3	4
08:30 AM	0	0	0	0	0	0	0	1	1	0	0	0	1
*** BREAK ***													
<b>Total</b>	<b>0</b>	<b>0</b>	<b>0</b>	<b>0</b>	<b>0</b>	<b>0</b>	<b>1</b>	<b>1</b>	<b>2</b>	<b>2</b>	<b>1</b>	<b>3</b>	<b>5</b>
*** BREAK ***													
04:00 PM	0	0	0	0	0	0	1	0	1	0	0	0	1
04:15 PM	0	0	0	0	0	0	0	0	0	1	1	2	2
04:30 PM	0	0	0	0	0	0	1	0	1	1	0	1	2
04:45 PM	0	0	0	0	0	0	2	0	2	1	0	1	3
<b>Total</b>	<b>0</b>	<b>0</b>	<b>0</b>	<b>0</b>	<b>0</b>	<b>0</b>	<b>4</b>	<b>0</b>	<b>4</b>	<b>3</b>	<b>1</b>	<b>4</b>	<b>8</b>
05:00 PM	0	0	0	0	0	0	1	0	1	2	1	3	4
05:15 PM	1	0	1	0	0	0	2	0	2	7	0	7	10
05:30 PM	0	0	0	0	0	0	1	0	1	1	0	1	2
05:45 PM	0	0	0	0	0	0	2	2	4	2	0	2	6
<b>Total</b>	<b>1</b>	<b>0</b>	<b>1</b>	<b>0</b>	<b>0</b>	<b>0</b>	<b>6</b>	<b>2</b>	<b>8</b>	<b>12</b>	<b>1</b>	<b>13</b>	<b>22</b>
<b>Grand Total</b>	<b>3</b>	<b>0</b>	<b>3</b>	<b>1</b>	<b>0</b>	<b>1</b>	<b>13</b>	<b>3</b>	<b>16</b>	<b>25</b>	<b>3</b>	<b>28</b>	<b>48</b>
Apprch %	100	0		100	0		81.2	18.8		89.3	10.7		
Total %	6.2	0	6.2	2.1	0	2.1	27.1	6.2	33.3	52.1	6.2	58.3	

# Malaga Avenue at Salzedo Street

File Name : TMC-2 Malaga Avenue at Salzedo Street  
 Site Code : 00000000  
 Start Date : 8/31/2021  
 Page No : 3

Start Time	Salzedo Street Southbound			Salzedo Street Northbound			Malaga Avenue Westbound			Malaga Avenue Eastbound			Int. Total
	Peds	Bikes	App. Total	Peds	Bikes	App. Total	Peds	Bikes	App. Total	Peds	Bikes	App. Total	
Peak Hour Analysis From 07:00 AM to 08:45 AM - Peak 1 of 1													
Peak Hour for Entire Intersection Begins at 07:00 AM													
07:00 AM	0	0	0	0	0	0	1	0	1	2	0	2	3
07:15 AM	0	0	0	0	0	0	0	0	0	2	0	2	2
07:30 AM	1	0	1	1	0	1	1	0	1	2	0	2	5
07:45 AM	1	0	1	0	0	0	0	0	0	2	0	2	3
Total Volume	2	0	2	1	0	1	2	0	2	8	0	8	13
% App. Total	100	0		100	0		100	0		100	0		
PHF	.500	.000	.500	.250	.000	.250	.500	.000	.500	1.00	.000	1.00	.650

# Malaga Avenue at Salzedo Street

File Name : TMC-2 Malaga Avenue at Salzedo Street  
 Site Code : 00000000  
 Start Date : 8/31/2021  
 Page No : 5

Start Time	Salzedo Street Southbound			Salzedo Street Northbound			Malaga Avenue Westbound			Malaga Avenue Eastbound			Int. Total
	Peds	Bikes	App. Total	Peds	Bikes	App. Total	Peds	Bikes	App. Total	Peds	Bikes	App. Total	
Peak Hour Analysis From 04:00 PM to 05:45 PM - Peak 1 of 1													
Peak Hour for Entire Intersection Begins at 05:00 PM													
05:00 PM	0	0	0	0	0	0	1	0	1	2	1	3	4
05:15 PM	1	0	1	0	0	0	2	0	2	7	0	7	10
05:30 PM	0	0	0	0	0	0	1	0	1	1	0	1	2
05:45 PM	0	0	0	0	0	0	2	2	4	2	0	2	6
Total Volume	1	0	1	0	0	0	6	2	8	12	1	13	22
% App. Total	100	0		0	0		75	25		92.3	7.7		
PHF	.250	.000	.250	.000	.000	.000	.750	.250	.500	.429	.250	.464	.550

# University Dr at Le Jeune Rd

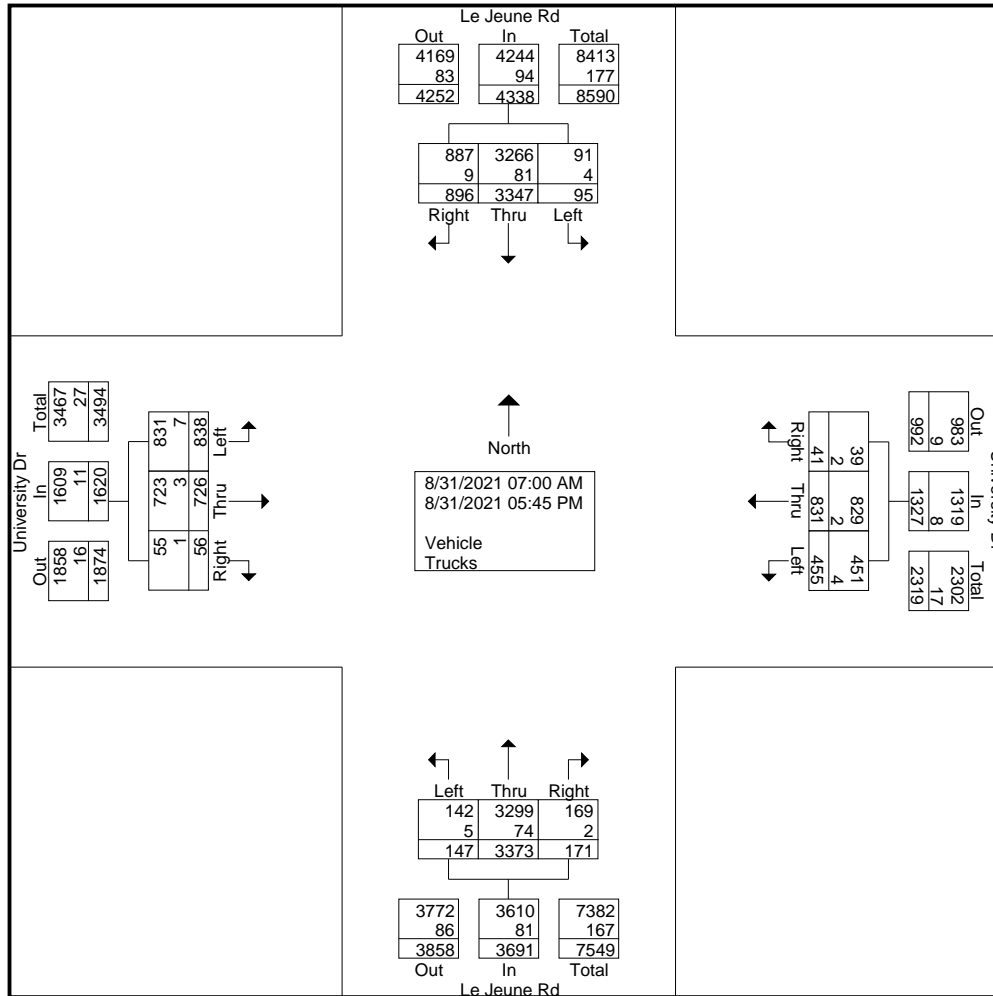
File Name : TMC-3 University Dr at Le Jeune Rd  
 Site Code : 00000000  
 Start Date : 8/31/2021  
 Page No : 1

## Groups Printed- Vehicle - Trucks

Start Time	Le Jeune Rd Southbound					Le Jeune Rd Northbound					University Dr Westbound					University Dr Eastbound					Int. Total
	U-Turns	Left	Thru	Right	App. Total	U-Turns	Left	Thru	Right	App. Total	U-Turns	Left	Thru	Right	App. Total	U-Turns	Left	Thru	Right	App. Total	
07:00 AM	0	5	175	40	220	0	7	186	16	209	0	6	21	4	31	0	64	61	2	127	587
07:15 AM	0	7	166	37	210	0	4	157	9	170	0	7	18	2	27	0	65	54	4	123	530
07:30 AM	0	8	233	47	288	0	2	158	10	170	0	11	34	1	46	0	62	55	2	119	623
07:45 AM	0	11	232	31	274	0	8	183	12	203	0	12	30	1	43	0	71	60	2	133	653
<b>Total</b>	<b>0</b>	<b>31</b>	<b>806</b>	<b>155</b>	<b>992</b>	<b>0</b>	<b>21</b>	<b>684</b>	<b>47</b>	<b>752</b>	<b>0</b>	<b>36</b>	<b>103</b>	<b>8</b>	<b>147</b>	<b>0</b>	<b>262</b>	<b>230</b>	<b>10</b>	<b>502</b>	<b>2393</b>
08:00 AM	0	6	244	53	303	0	2	209	10	221	0	19	29	4	52	0	72	55	2	129	705
08:15 AM	0	4	238	43	285	0	4	240	11	255	0	17	27	5	49	0	61	70	2	133	722
08:30 AM	0	3	237	45	285	0	5	239	21	265	0	21	42	1	64	0	72	67	5	144	758
08:45 AM	0	7	174	27	208	0	5	235	20	260	0	9	27	6	42	0	89	88	1	178	688
<b>Total</b>	<b>0</b>	<b>20</b>	<b>893</b>	<b>168</b>	<b>1081</b>	<b>0</b>	<b>16</b>	<b>923</b>	<b>62</b>	<b>1001</b>	<b>0</b>	<b>66</b>	<b>125</b>	<b>16</b>	<b>207</b>	<b>0</b>	<b>294</b>	<b>280</b>	<b>10</b>	<b>584</b>	<b>2873</b>
*** BREAK ***																					
04:00 PM	0	4	182	67	253	0	15	219	7	241	0	34	51	4	89	0	37	24	4	65	648
04:15 PM	0	9	197	63	269	0	13	245	9	267	0	34	59	1	94	0	51	30	4	85	715
04:30 PM	0	4	182	55	241	0	11	206	4	221	0	40	85	3	128	0	33	36	2	71	661
04:45 PM	0	5	205	66	276	0	13	244	9	266	0	30	58	3	91	0	38	22	2	62	695
<b>Total</b>	<b>0</b>	<b>22</b>	<b>766</b>	<b>251</b>	<b>1039</b>	<b>0</b>	<b>52</b>	<b>914</b>	<b>29</b>	<b>995</b>	<b>0</b>	<b>138</b>	<b>253</b>	<b>11</b>	<b>402</b>	<b>0</b>	<b>159</b>	<b>112</b>	<b>12</b>	<b>283</b>	<b>2719</b>
05:00 PM	1	5	252	75	333	0	14	235	10	259	0	61	97	3	161	0	28	21	8	57	810
05:15 PM	0	10	194	86	290	0	17	248	11	276	0	53	91	1	145	0	32	29	3	64	775
05:30 PM	0	2	205	75	282	0	14	183	5	202	0	58	78	0	136	0	31	28	6	65	685
05:45 PM	1	3	231	86	321	0	13	186	7	206	0	43	84	2	129	0	32	26	7	65	721
<b>Total</b>	<b>2</b>	<b>20</b>	<b>882</b>	<b>322</b>	<b>1226</b>	<b>0</b>	<b>58</b>	<b>852</b>	<b>33</b>	<b>943</b>	<b>0</b>	<b>215</b>	<b>350</b>	<b>6</b>	<b>571</b>	<b>0</b>	<b>123</b>	<b>104</b>	<b>24</b>	<b>251</b>	<b>2991</b>
<b>Grand Total</b>	<b>2</b>	<b>93</b>	<b>3347</b>	<b>896</b>	<b>4338</b>	<b>0</b>	<b>147</b>	<b>3373</b>	<b>171</b>	<b>3691</b>	<b>0</b>	<b>455</b>	<b>831</b>	<b>41</b>	<b>1327</b>	<b>0</b>	<b>838</b>	<b>726</b>	<b>56</b>	<b>1620</b>	<b>10976</b>
Apprch %	0	2.1	77.2	20.7		0	4	91.4	4.6		0	34.3	62.6	3.1		0	51.7	44.8	3.5		
Total %	0	0.8	30.5	8.2	39.5	0	1.3	30.7	1.6	33.6	0	4.1	7.6	0.4	12.1	0	7.6	6.6	0.5	14.8	
Vehicle	2	89	3266	887	4244	0	142	3299	169	3610	0	451	829	39	1319	0	831	723	55	1609	10782
% Vehicle	100	95.7	97.6	99	97.8	0	96.6	97.8	98.8	97.8	0	99.1	99.8	95.1	99.4	0	99.2	99.6	98.2	99.3	98.2
Trucks	0	4	81	9	94	0	5	74	2	81	0	4	2	2	8	0	7	3	1	11	194
% Trucks	0	4.3	2.4	1	2.2	0	3.4	2.2	1.2	2.2	0	0.9	0.2	4.9	0.6	0	0.8	0.4	1.8	0.7	1.8

# University Dr at Le Jeune Rd

File Name : TMC-3 University Dr at Le Jeune Rd  
 Site Code : 00000000  
 Start Date : 8/31/2021  
 Page No : 2



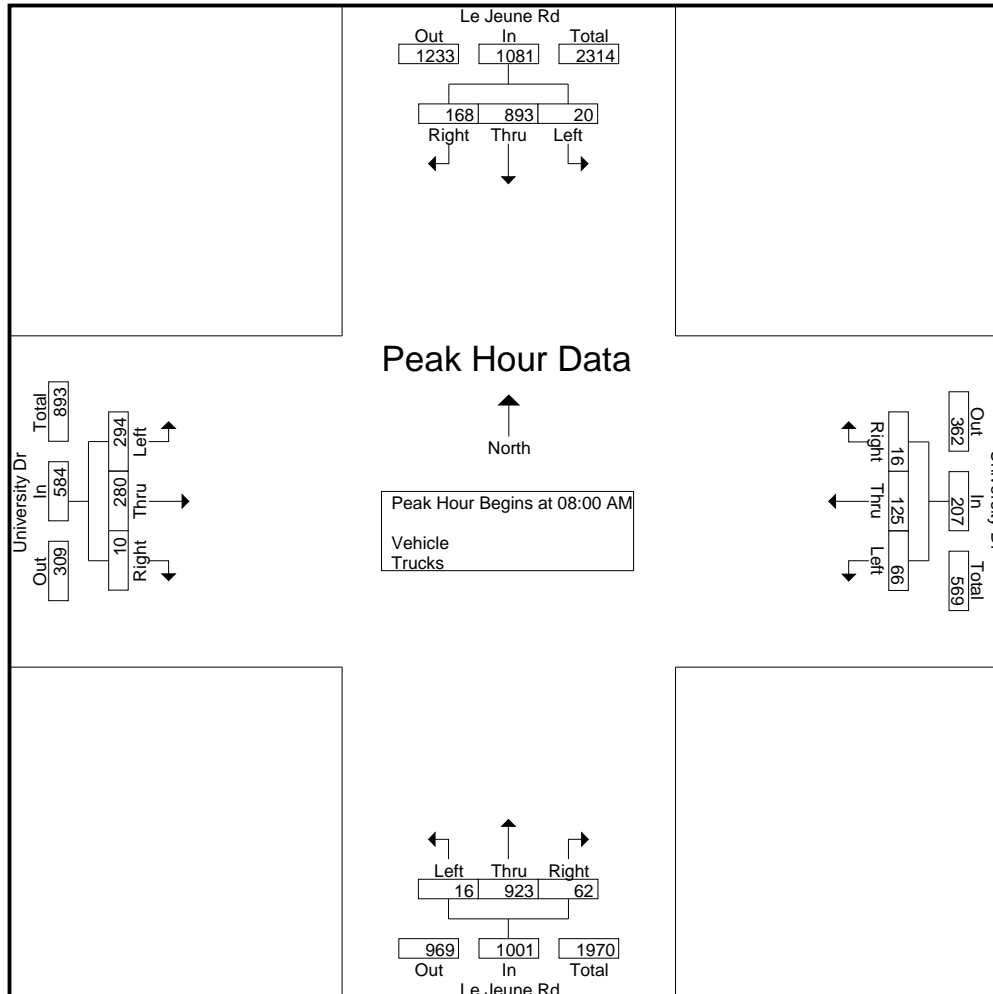
# University Dr at Le Jeune Rd

File Name : TMC-3 University Dr at Le Jeune Rd  
 Site Code : 00000000  
 Start Date : 8/31/2021  
 Page No : 3

Start Time	Le Jeune Rd Southbound					Le Jeune Rd Northbound					University Dr Westbound					University Dr Eastbound					Int. Total
	U-Turns	Left	Thru	Right	App. Total	U-Turns	Left	Thru	Right	App. Total	U-Turns	Left	Thru	Right	App. Total	U-Turns	Left	Thru	Right	App. Total	
Peak Hour Analysis From 07:00 AM to 08:45 AM - Peak 1 of 1																					
Peak Hour for Entire Intersection Begins at 08:00 AM																					
08:00 AM	0	6	<b>244</b>	<b>53</b>	<b>303</b>	0	2	209	10	221	0	19	29	4	52	0	72	55	2	129	705
08:15 AM	0	4	238	43	285	0	4	<b>240</b>	11	255	0	17	27	5	49	0	61	70	2	133	722
08:30 AM	0	3	237	45	285	0	<b>5</b>	239	<b>21</b>	<b>265</b>	0	<b>21</b>	<b>42</b>	1	<b>64</b>	0	72	67	<b>5</b>	144	<b>758</b>
08:45 AM	0	<b>7</b>	174	27	208	0	5	235	20	260	0	9	27	<b>6</b>	42	0	<b>89</b>	<b>88</b>	1	<b>178</b>	688
Total Volume	0	20	893	168	1081	0	16	923	62	1001	0	66	125	16	207	0	294	280	10	584	2873
% App. Total	0	1.9	82.6	15.5		0	1.6	92.2	6.2		0	31.9	60.4	7.7		0	50.3	47.9	1.7		
PHF	.000	.714	.915	.792	.892	.000	.800	.961	.738	.944	.000	.786	.744	.667	.809	.000	.826	.795	.500	.820	.948

# University Dr at Le Jeune Rd

File Name : TMC-3 University Dr at Le Jeune Rd  
 Site Code : 00000000  
 Start Date : 8/31/2021  
 Page No : 4

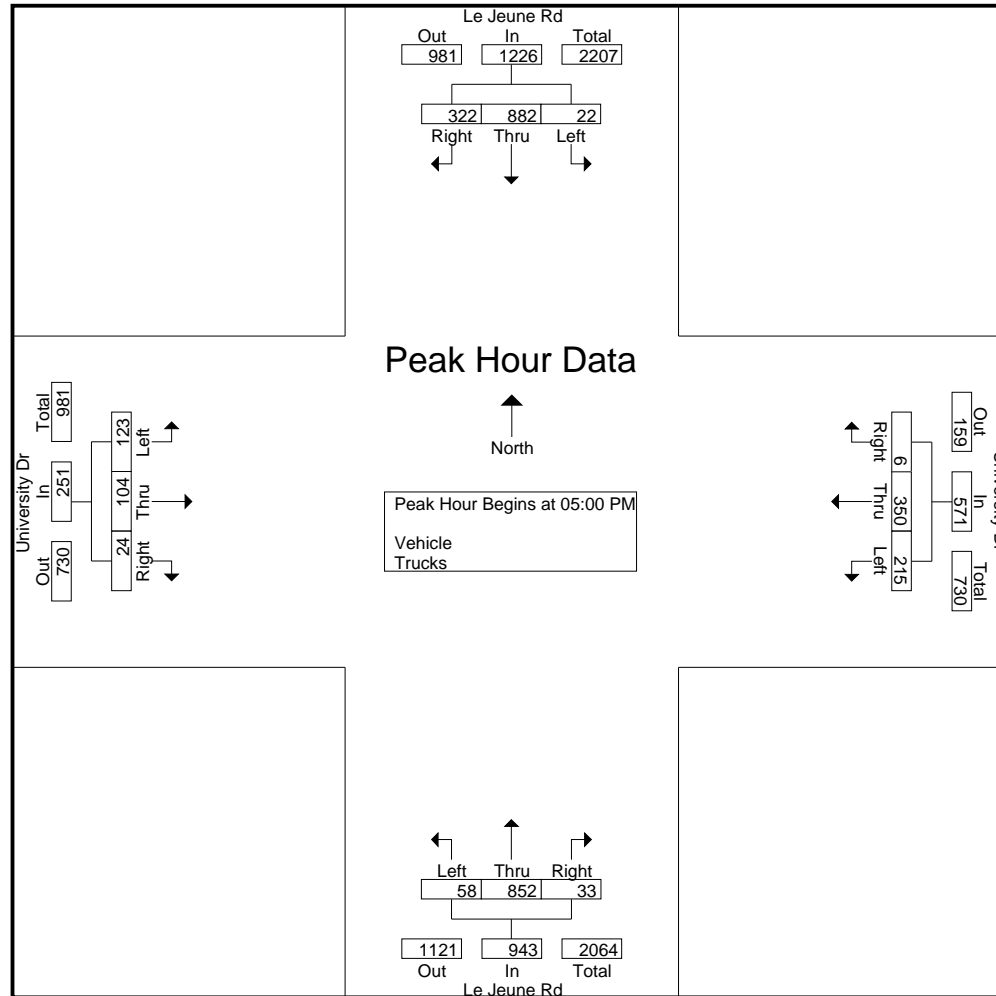




# University Dr at Le Jeune Rd

File Name : TMC-3 University Dr at Le Jeune Rd  
 Site Code : 00000000  
 Start Date : 8/31/2021  
 Page No : 5

Start Time	Le Jeune Rd Southbound					Le Jeune Rd Northbound					University Dr Westbound					University Dr Eastbound					Int. Total
	U-Turns	Left	Thru	Right	App. Total	U-Turns	Left	Thru	Right	App. Total	U-Turns	Left	Thru	Right	App. Total	U-Turns	Left	Thru	Right	App. Total	
Peak Hour Analysis From 04:00 PM to 05:45 PM - Peak 1 of 1																					
Peak Hour for Entire Intersection Begins at 05:00 PM																					
05:00 PM	1	5	252	75	333	0	14	235	10	259	0	61	97	3	161	0	28	21	8	57	810
05:15 PM	0	10	194	86	290	0	17	248	11	276	0	53	91	1	145	0	32	29	3	64	775
05:30 PM	0	2	205	75	282	0	14	183	5	202	0	58	78	0	136	0	31	28	6	65	685
05:45 PM	1	3	231	86	321	0	13	186	7	206	0	43	84	2	129	0	32	26	7	65	721
<b>Total Volume</b>	2	20	882	322	1226	0	58	852	33	943	0	215	350	6	571	0	123	104	24	251	2991
<b>% App. Total</b>	0.2	1.6	71.9	26.3		0	6.2	90.3	3.5		0	37.7	61.3	1.1		0	49	41.4	9.6		
PHF	.500	.500	.875	.936	.920	.000	.853	.859	.750	.854	.000	.881	.902	.500	.887	.000	.961	.897	.750	.965	.923



# University Dr at Le Jeune Rd

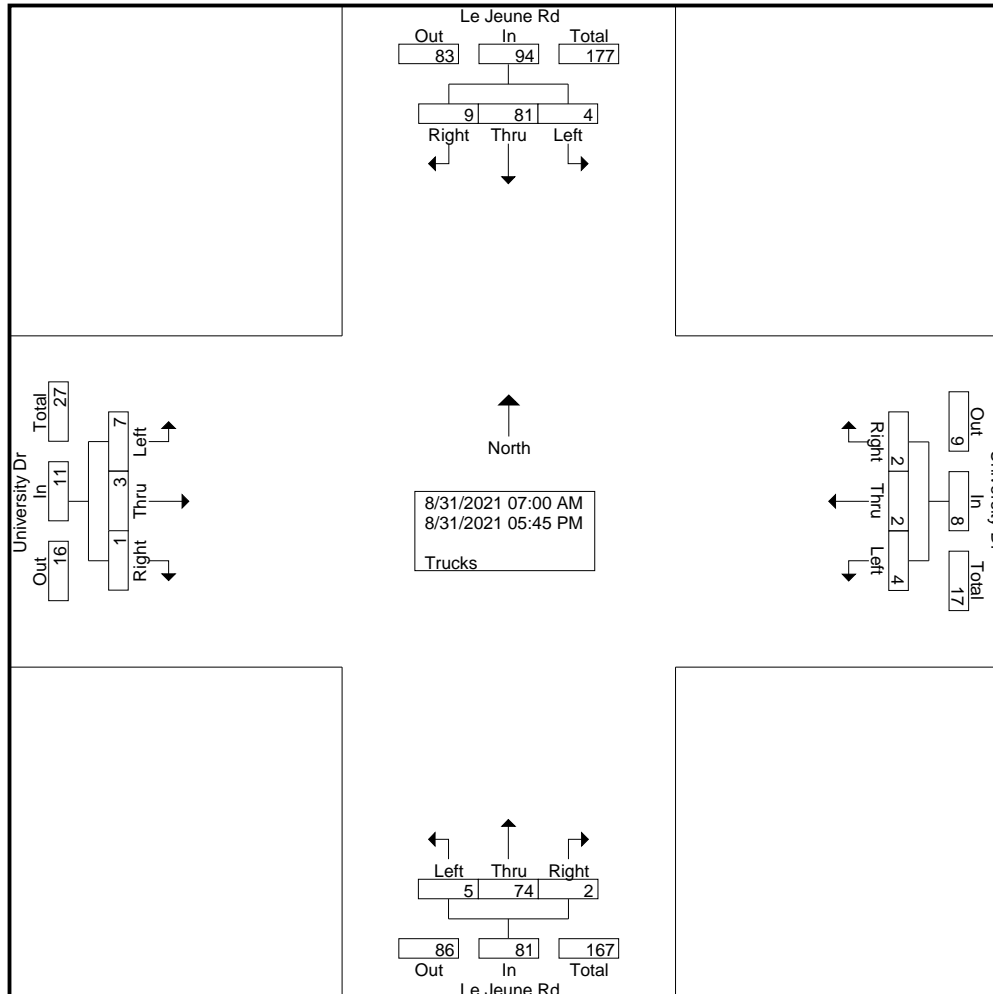
File Name : TMC-3 University Dr at Le Jeune Rd  
 Site Code : 00000000  
 Start Date : 8/31/2021  
 Page No : 1

## Groups Printed- Trucks

Start Time	Le Jeune Rd Southbound					Le Jeune Rd Northbound					University Dr Westbound					University Dr Eastbound					Int. Total
	U-Turns	Left	Thru	Right	App. Total	U-Turns	Left	Thru	Right	App. Total	U-Turns	Left	Thru	Right	App. Total	U-Turns	Left	Thru	Right	App. Total	
07:00 AM	0	0	4	0	4	0	2	5	0	7	0	0	0	0	0	0	0	0	0	0	0
07:15 AM	0	1	7	1	9	0	0	1	1	2	0	0	0	0	0	0	2	0	0	2	13
07:30 AM	0	0	6	1	7	0	0	4	0	4	0	0	0	0	0	0	1	0	0	1	12
07:45 AM	0	1	5	1	7	0	0	3	0	3	0	0	0	0	0	0	0	0	0	0	10
<b>Total</b>	<b>0</b>	<b>2</b>	<b>22</b>	<b>3</b>	<b>27</b>	<b>0</b>	<b>2</b>	<b>13</b>	<b>1</b>	<b>16</b>	<b>0</b>	<b>0</b>	<b>0</b>	<b>0</b>	<b>0</b>	<b>0</b>	<b>3</b>	<b>0</b>	<b>0</b>	<b>3</b>	<b>46</b>
08:00 AM	0	2	6	0	8	0	1	5	0	6	0	0	0	0	0	0	0	1	0	1	15
08:15 AM	0	0	9	1	10	0	0	2	0	2	0	0	0	0	0	0	1	0	0	1	13
08:30 AM	0	0	7	0	7	0	0	2	1	3	0	1	0	0	1	0	0	0	0	0	11
08:45 AM	0	0	9	0	9	0	0	5	0	5	0	0	0	1	1	0	1	1	0	2	17
<b>Total</b>	<b>0</b>	<b>2</b>	<b>31</b>	<b>1</b>	<b>34</b>	<b>0</b>	<b>1</b>	<b>14</b>	<b>1</b>	<b>16</b>	<b>0</b>	<b>1</b>	<b>0</b>	<b>1</b>	<b>2</b>	<b>0</b>	<b>2</b>	<b>2</b>	<b>0</b>	<b>4</b>	<b>56</b>
*** BREAK ***																					
04:00 PM	0	0	3	1	4	0	1	6	0	7	0	2	0	0	2	0	0	0	1	1	14
04:15 PM	0	0	6	0	6	0	0	9	0	9	0	1	0	0	1	0	2	0	0	2	18
04:30 PM	0	0	6	2	8	0	1	8	0	9	0	0	1	1	2	0	0	0	0	0	19
04:45 PM	0	0	3	0	3	0	0	6	0	6	0	0	0	0	0	0	0	0	0	0	9
<b>Total</b>	<b>0</b>	<b>0</b>	<b>18</b>	<b>3</b>	<b>21</b>	<b>0</b>	<b>2</b>	<b>29</b>	<b>0</b>	<b>31</b>	<b>0</b>	<b>3</b>	<b>1</b>	<b>1</b>	<b>5</b>	<b>0</b>	<b>2</b>	<b>0</b>	<b>1</b>	<b>3</b>	<b>60</b>
05:00 PM	0	0	2	1	3	0	0	4	0	4	0	0	0	0	0	0	0	1	0	1	8
05:15 PM	0	0	2	0	2	0	0	3	0	3	0	0	1	0	1	0	0	0	0	0	6
05:30 PM	0	0	3	1	4	0	0	4	0	4	0	0	0	0	0	0	0	0	0	0	8
05:45 PM	0	0	3	0	3	0	0	7	0	7	0	0	0	0	0	0	0	0	0	0	10
<b>Total</b>	<b>0</b>	<b>0</b>	<b>10</b>	<b>2</b>	<b>12</b>	<b>0</b>	<b>0</b>	<b>18</b>	<b>0</b>	<b>18</b>	<b>0</b>	<b>0</b>	<b>1</b>	<b>0</b>	<b>1</b>	<b>0</b>	<b>0</b>	<b>1</b>	<b>0</b>	<b>1</b>	<b>32</b>
<b>Grand Total</b>	<b>0</b>	<b>4</b>	<b>81</b>	<b>9</b>	<b>94</b>	<b>0</b>	<b>5</b>	<b>74</b>	<b>2</b>	<b>81</b>	<b>0</b>	<b>4</b>	<b>2</b>	<b>2</b>	<b>8</b>	<b>0</b>	<b>7</b>	<b>3</b>	<b>1</b>	<b>11</b>	<b>194</b>
Apprch %	0	4.3	86.2	9.6		0	6.2	91.4	2.5		0	50	25	25		0	63.6	27.3	9.1		
Total %	0	2.1	41.8	4.6	48.5	0	2.6	38.1	1	41.8	0	2.1	1	1	4.1	0	3.6	1.5	0.5	5.7	

# University Dr at Le Jeune Rd

File Name : TMC-3 University Dr at Le Jeune Rd  
 Site Code : 00000000  
 Start Date : 8/31/2021  
 Page No : 2



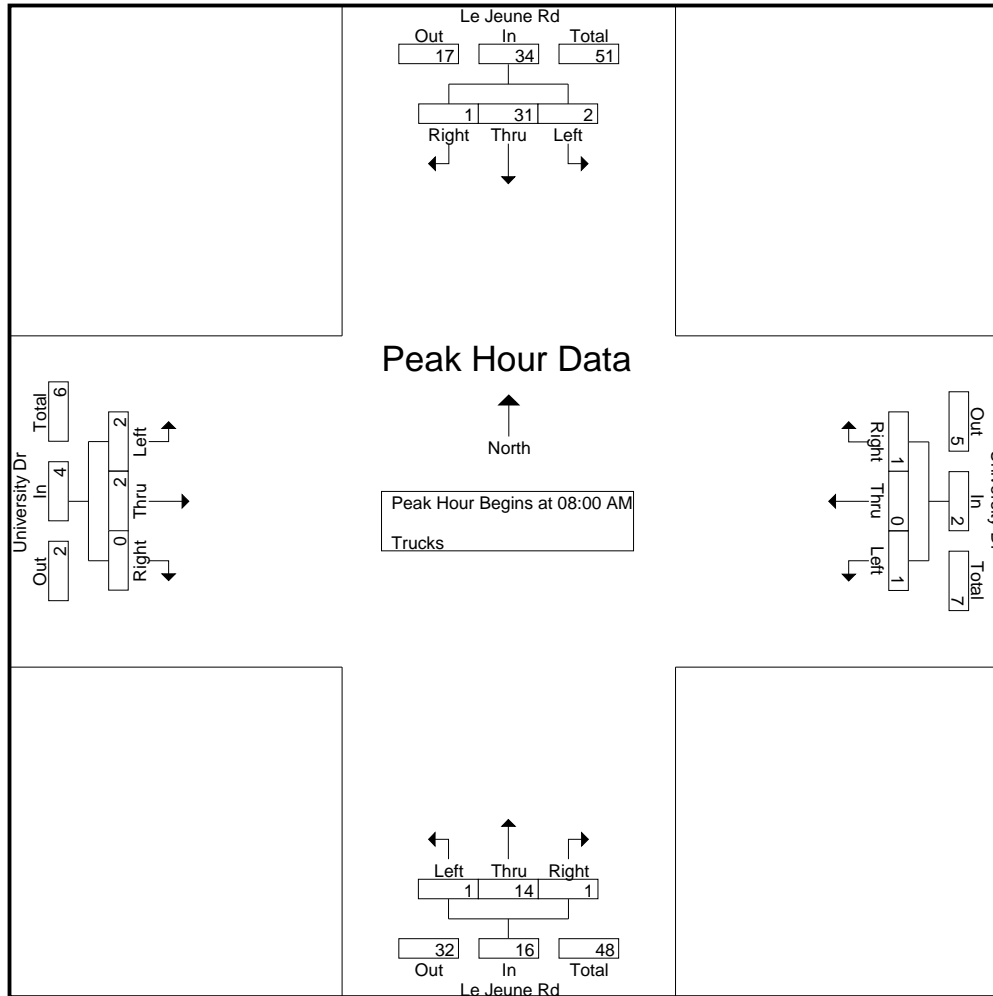
# University Dr at Le Jeune Rd

File Name : TMC-3 University Dr at Le Jeune Rd  
 Site Code : 00000000  
 Start Date : 8/31/2021  
 Page No : 3

Start Time	Le Jeune Rd Southbound					Le Jeune Rd Northbound					University Dr Westbound					University Dr Eastbound					Int. Total
	U-Turns	Left	Thru	Right	App. Total	U-Turns	Left	Thru	Right	App. Total	U-Turns	Left	Thru	Right	App. Total	U-Turns	Left	Thru	Right	App. Total	
Peak Hour Analysis From 07:00 AM to 08:45 AM - Peak 1 of 1																					
Peak Hour for Entire Intersection Begins at 08:00 AM																					
08:00 AM	0	2	6	0	8	0	1	5	0	6	0	0	0	0	0	0	0	1	0	1	15
08:15 AM	0	0	9	1	10	0	0	2	0	2	0	0	0	0	0	0	1	0	0	1	13
08:30 AM	0	0	7	0	7	0	0	2	1	3	0	1	0	0	1	0	0	0	0	0	11
08:45 AM	0	0	9	0	9	0	0	5	0	5	0	0	0	1	1	0	1	1	0	2	17
Total Volume	0	2	31	1	34	0	1	14	1	16	0	1	0	1	2	0	2	2	0	4	56
% App. Total	0	5.9	91.2	2.9		0	6.2	87.5	6.2		0	50	0	50		0	50	50	0		
PHF	.000	.250	.861	.250	.850	.000	.250	.700	.250	.667	.000	.250	.000	.250	.500	.000	.500	.500	.000	.500	.824

# University Dr at Le Jeune Rd

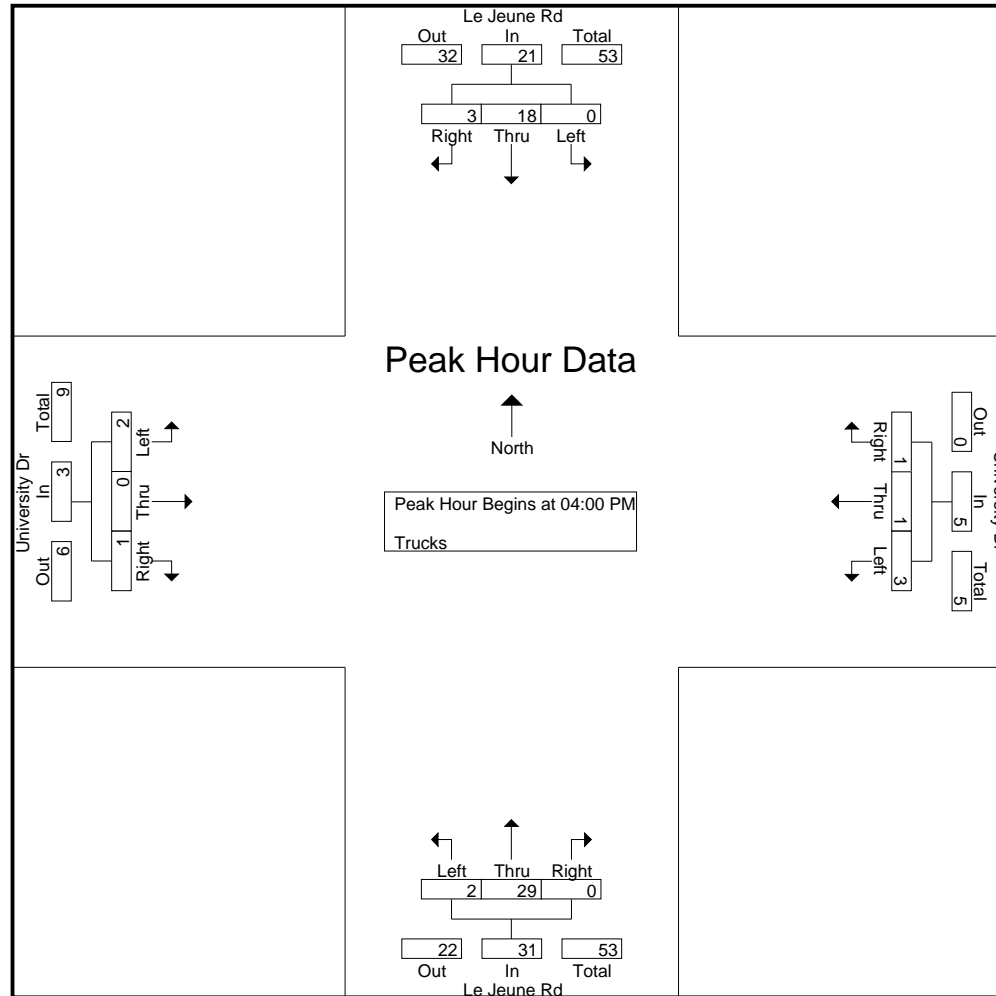
File Name : TMC-3 University Dr at Le Jeune Rd  
 Site Code : 00000000  
 Start Date : 8/31/2021  
 Page No : 4



# University Dr at Le Jeune Rd

File Name : TMC-3 University Dr at Le Jeune Rd  
 Site Code : 00000000  
 Start Date : 8/31/2021  
 Page No : 5

Start Time	Le Jeune Rd Southbound					Le Jeune Rd Northbound					University Dr Westbound					University Dr Eastbound					Int. Total
	U-Turns	Left	Thru	Right	App. Total	U-Turns	Left	Thru	Right	App. Total	U-Turns	Left	Thru	Right	App. Total	U-Turns	Left	Thru	Right	App. Total	
Peak Hour Analysis From 04:00 PM to 05:45 PM - Peak 1 of 1																					
Peak Hour for Entire Intersection Begins at 04:00 PM																					
04:00 PM	0	0	3	1	4	0	1	6	0	7	0	2	0	0	2	0	0	0	1	1	14
04:15 PM	0	0	6	0	6	0	0	9	0	9	0	1	0	0	1	0	2	0	0	2	18
04:30 PM	0	0	6	2	8	0	1	8	0	9	0	0	1	1	2	0	0	0	0	0	19
04:45 PM	0	0	3	0	3	0	0	6	0	6	0	0	0	0	0	0	0	0	0	0	9
Total Volume	0	0	18	3	21	0	2	29	0	31	0	3	1	1	5	0	2	0	1	3	60
% App. Total	0	0	85.7	14.3		0	6.5	93.5	0		0	60	20	20		0	66.7	0	33.3		
PHF	.000	.000	.750	.375	.656	.000	.500	.806	.000	.861	.000	.375	.250	.250	.625	.000	.250	.000	.250	.375	.789



# University Dr at Le Jeune Rd

File Name : TMC-3 University Dr at Le Jeune Rd  
 Site Code : 00000000  
 Start Date : 8/31/2021  
 Page No : 1

### Groups Printed- Peds & Bikes

Start Time	Le Jeune Rd Southbound			Le Jeune Rd Northbound			University Dr Westbound			University Dr Eastbound			Int. Total
	Peds	Bikes	App. Total	Peds	Bikes	App. Total	Peds	Bikes	App. Total	Peds	Bikes	App. Total	
07:00 AM	1	0	1	0	0	0	0	1	1	0	1	1	3
07:15 AM	0	0	0	0	0	0	0	0	0	1	0	1	1
07:30 AM	1	0	1	0	0	0	0	0	0	0	0	0	1
07:45 AM	2	0	2	0	0	0	0	0	0	0	0	0	2
Total	4	0	4	0	0	0	0	1	1	1	1	2	7
08:00 AM	2	2	4	0	0	0	0	1	1	0	0	0	5
08:15 AM	3	0	3	0	0	0	1	0	1	0	0	0	4
08:30 AM	1	0	1	1	0	1	0	0	0	0	0	0	2
*** BREAK ***													
Total	6	2	8	1	0	1	1	1	2	0	0	0	11
*** BREAK ***													
04:00 PM	0	0	0	2	0	2	0	0	0	0	0	0	2
*** BREAK ***													
04:30 PM	1	1	2	0	0	0	1	1	2	0	0	0	4
04:45 PM	0	0	0	0	0	0	0	0	0	1	0	1	1
Total	1	1	2	2	0	2	1	1	2	1	0	1	7
05:00 PM	1	0	1	0	0	0	1	0	1	0	0	0	2
*** BREAK ***													
05:30 PM	0	0	0	0	0	0	0	1	1	1	0	1	2
*** BREAK ***													
Total	1	0	1	0	0	0	1	1	2	1	0	1	4
Grand Total	12	3	15	3	0	3	3	4	7	3	1	4	29
Apprch %	80	20		100	0		42.9	57.1		75	25		
Total %	41.4	10.3	51.7	10.3	0	10.3	10.3	13.8	24.1	10.3	3.4	13.8	

# University Dr at Le Jeune Rd

File Name : TMC-3 University Dr at Le Jeune Rd  
 Site Code : 00000000  
 Start Date : 8/31/2021  
 Page No : 3

Start Time	Le Jeune Rd Southbound			Le Jeune Rd Northbound			University Dr Westbound			University Dr Eastbound			Int. Total
	Peds	Bikes	App. Total	Peds	Bikes	App. Total	Peds	Bikes	App. Total	Peds	Bikes	App. Total	
Peak Hour Analysis From 07:00 AM to 08:45 AM - Peak 1 of 1													
Peak Hour for Entire Intersection Begins at 07:45 AM													
07:45 AM	2	0	2	0	0	0	0	0	0	0	0	0	2
08:00 AM	2	2	4	0	0	0	0	1	1	1	0	0	5
08:15 AM	3	0	3	0	0	0	1	0	1	0	0	0	4
08:30 AM	1	0	1	1	0	1	0	0	0	0	0	0	2
Total Volume	8	2	10	1	0	1	1	1	2	0	0	0	13
% App. Total	80	20		100	0		50	50		0	0		
PHF	.667	.250	.625	.250	.000	.250	.250	.250	.500	.000	.000	.000	.650



# University Dr at Le Jeune Rd

File Name : TMC-3 University Dr at Le Jeune Rd  
 Site Code : 00000000  
 Start Date : 8/31/2021  
 Page No : 5

Start Time	Le Jeune Rd Southbound			Le Jeune Rd Northbound			University Dr Westbound			University Dr Eastbound			Int. Total
	Peds	Bikes	App. Total	Peds	Bikes	App. Total	Peds	Bikes	App. Total	Peds	Bikes	App. Total	
Peak Hour Analysis From 04:00 PM to 05:45 PM - Peak 1 of 1													
Peak Hour for Entire Intersection Begins at 04:00 PM													
04:00 PM	0	0	0	2	0	2	0	0	0	0	0	0	2
04:15 PM	0	0	0	0	0	0	0	0	0	0	0	0	0
04:30 PM	1	1	2	0	0	0	1	1	2	0	0	0	4
04:45 PM	0	0	0	0	0	0	0	0	0	1	0	1	1
Total Volume	1	1	2	2	0	2	1	1	2	1	0	1	7
% App. Total	50	50		100	0		50	50		100	0		
PHF	.250	.250	.250	.250	.000	.250	.250	.250	.250	.250	.000	.250	.438

# Malaga Avenue at Le Jeune Rd

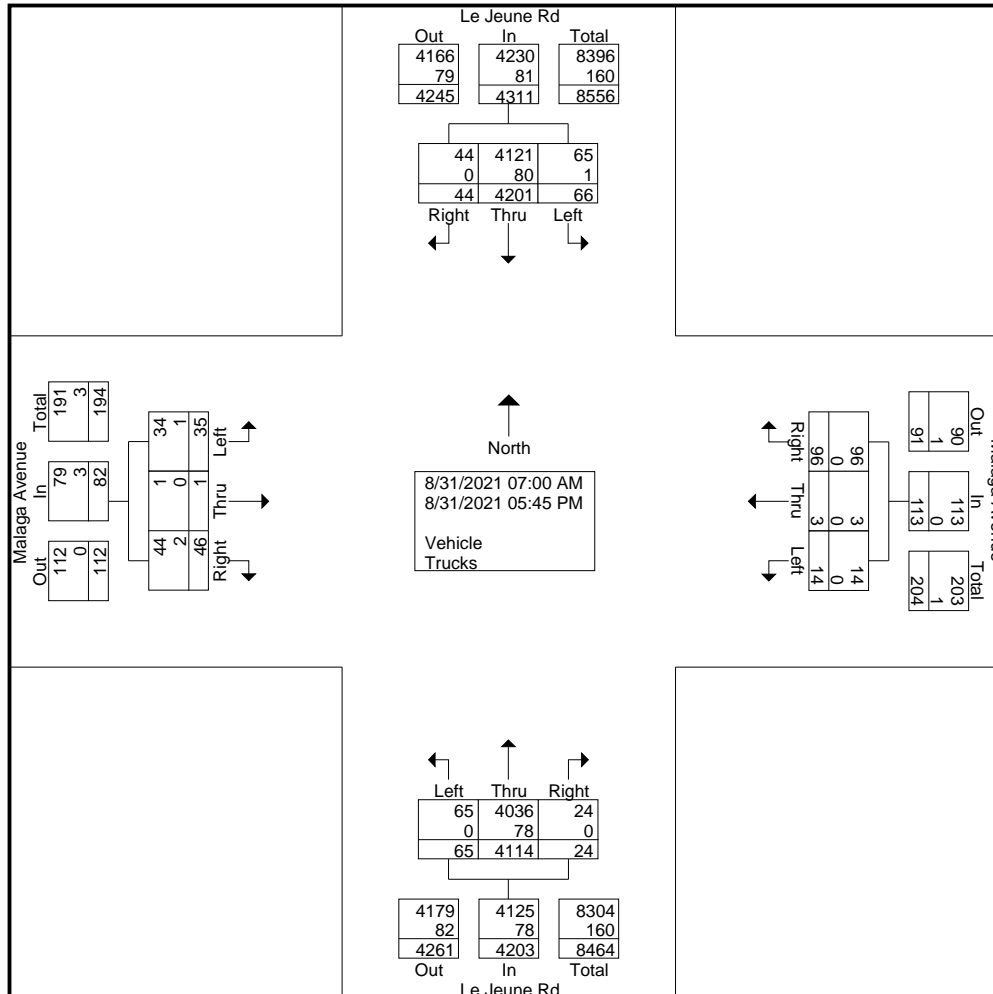
File Name : TMC-4 Malaga Avenue at Le Jeune Rd  
 Site Code : 00000000  
 Start Date : 8/31/2021  
 Page No : 1

## Groups Printed- Vehicle - Trucks

Start Time	Le Jeune Rd Southbound					Le Jeune Rd Northbound					Malaga Avenue Westbound					Malaga Avenue Eastbound					Int. Total
	U-Turns	Left	Thru	Right	App. Total	U-Turns	Left	Thru	Right	App. Total	U-Turns	Left	Thru	Right	App. Total	U-Turns	Left	Thru	Right	App. Total	
07:00 AM	0	5	235	1	241	0	0	270	1	271	0	1	0	3	4	0	3	0	4	7	523
07:15 AM	0	2	203	0	205	0	4	239	1	244	0	0	0	4	4	0	7	0	3	10	463
07:30 AM	0	1	258	0	259	0	1	220	1	222	0	0	0	5	5	0	4	0	7	11	497
07:45 AM	0	4	250	2	256	0	2	236	1	239	0	1	0	3	4	0	1	0	4	5	504
<b>Total</b>	<b>0</b>	<b>12</b>	<b>946</b>	<b>3</b>	<b>961</b>	<b>0</b>	<b>7</b>	<b>965</b>	<b>4</b>	<b>976</b>	<b>0</b>	<b>2</b>	<b>0</b>	<b>15</b>	<b>17</b>	<b>0</b>	<b>15</b>	<b>0</b>	<b>18</b>	<b>33</b>	<b>1987</b>
08:00 AM	0	6	276	1	283	0	4	290	0	294	0	1	0	4	5	0	4	0	5	9	591
08:15 AM	0	6	254	2	262	0	5	313	2	320	0	1	0	2	3	0	2	1	4	7	592
08:30 AM	0	8	259	6	273	0	4	297	0	301	0	0	0	4	4	0	2	0	1	3	581
08:45 AM	0	12	244	1	257	0	2	322	2	326	0	2	0	3	5	0	0	0	2	2	590
<b>Total</b>	<b>0</b>	<b>32</b>	<b>1033</b>	<b>10</b>	<b>1075</b>	<b>0</b>	<b>15</b>	<b>1222</b>	<b>4</b>	<b>1241</b>	<b>0</b>	<b>4</b>	<b>0</b>	<b>13</b>	<b>17</b>	<b>0</b>	<b>8</b>	<b>1</b>	<b>12</b>	<b>21</b>	<b>2354</b>
*** BREAK ***																					
04:00 PM	0	2	255	1	258	0	1	207	0	208	0	1	0	6	7	0	1	0	1	2	475
04:15 PM	0	5	248	2	255	0	7	268	1	276	0	2	0	5	7	0	1	0	1	2	540
04:30 PM	1	3	251	2	257	0	11	250	2	263	0	1	2	6	9	0	2	0	3	5	534
04:45 PM	1	4	261	4	270	0	4	254	4	262	0	0	0	11	11	0	1	0	2	3	546
<b>Total</b>	<b>2</b>	<b>14</b>	<b>1015</b>	<b>9</b>	<b>1040</b>	<b>0</b>	<b>23</b>	<b>979</b>	<b>7</b>	<b>1009</b>	<b>0</b>	<b>4</b>	<b>2</b>	<b>28</b>	<b>34</b>	<b>0</b>	<b>5</b>	<b>0</b>	<b>7</b>	<b>12</b>	<b>2095</b>
05:00 PM	0	0	310	6	316	0	5	249	1	255	0	0	0	10	10	0	0	0	2	2	583
05:15 PM	0	2	285	8	295	0	5	280	3	288	0	2	0	13	15	0	2	0	1	3	601
05:30 PM	0	2	286	3	291	0	6	214	2	222	0	2	1	12	15	0	3	0	2	5	533
05:45 PM	0	2	326	5	333	0	4	205	3	212	0	0	0	5	5	0	2	0	4	6	556
<b>Total</b>	<b>0</b>	<b>6</b>	<b>1207</b>	<b>22</b>	<b>1235</b>	<b>0</b>	<b>20</b>	<b>948</b>	<b>9</b>	<b>977</b>	<b>0</b>	<b>4</b>	<b>1</b>	<b>40</b>	<b>45</b>	<b>0</b>	<b>7</b>	<b>0</b>	<b>9</b>	<b>16</b>	<b>2273</b>
<b>Grand Total</b>	<b>2</b>	<b>64</b>	<b>4201</b>	<b>44</b>	<b>4311</b>	<b>0</b>	<b>65</b>	<b>4114</b>	<b>24</b>	<b>4203</b>	<b>0</b>	<b>14</b>	<b>3</b>	<b>96</b>	<b>113</b>	<b>0</b>	<b>35</b>	<b>1</b>	<b>46</b>	<b>82</b>	<b>8709</b>
Apprch %	0	1.5	97.4	1		0	1.5	97.9	0.6		0	12.4	2.7	85		0	42.7	1.2	56.1		
Total %	0	0.7	48.2	0.5	49.5	0	0.7	47.2	0.3	48.3	0	0.2	0	1.1	1.3	0	0.4	0	0.5	0.9	
Vehicle	2	63	4121	44	4230	0	65	4036	24	4125	0	14	3	96	113	0	34	1	44	79	8547
% Vehicle	100	98.4	98.1	100	98.1	0	100	98.1	100	98.1	0	100	100	100	100	0	97.1	100	95.7	96.3	98.1
Trucks	0	1	80	0	81	0	0	78	0	78	0	0	0	0	0	0	1	0	2	3	162
% Trucks	0	1.6	1.9	0	1.9	0	0	1.9	0	1.9	0	0	0	0	0	0	2.9	0	4.3	3.7	1.9

# Malaga Avenue at Le Jeune Rd

File Name : TMC-4 Malaga Avenue at Le Jeune Rd  
 Site Code : 00000000  
 Start Date : 8/31/2021  
 Page No : 2



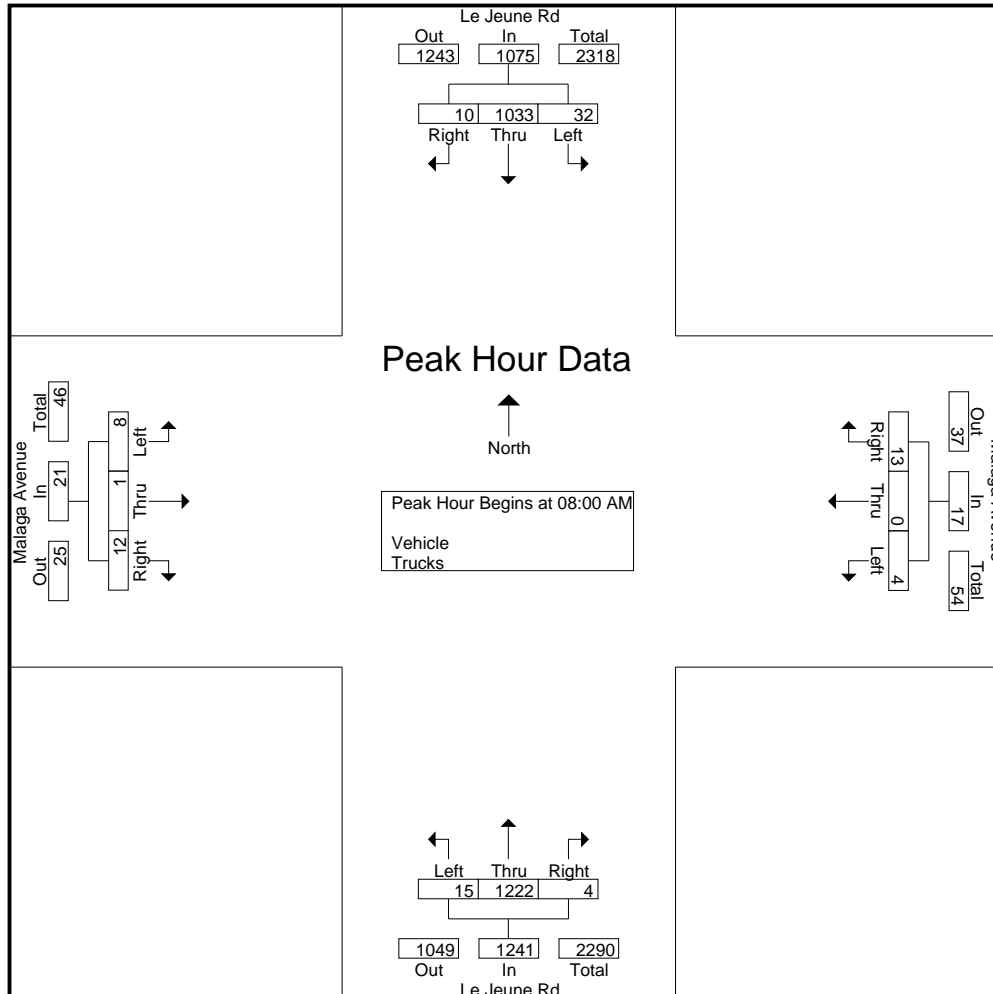
# Malaga Avenue at Le Jeune Rd

File Name : TMC-4 Malaga Avenue at Le Jeune Rd  
 Site Code : 00000000  
 Start Date : 8/31/2021  
 Page No : 3

Start Time	Le Jeune Rd Southbound					Le Jeune Rd Northbound					Malaga Avenue Westbound					Malaga Avenue Eastbound					Int. Total
	U-Turns	Left	Thru	Right	App. Total	U-Turns	Left	Thru	Right	App. Total	U-Turns	Left	Thru	Right	App. Total	U-Turns	Left	Thru	Right	App. Total	
Peak Hour Analysis From 07:00 AM to 08:45 AM - Peak 1 of 1																					
Peak Hour for Entire Intersection Begins at 08:00 AM																					
08:00 AM	0	6	276	1	283	0	4	290	0	294	0	1	0	4	5	0	4	0	5	9	591
08:15 AM	0	6	254	2	262	0	5	313	2	320	0	1	0	2	3	0	2	1	4	7	592
08:30 AM	0	8	259	6	273	0	4	297	0	301	0	0	0	4	4	0	2	0	1	3	581
08:45 AM	0	12	244	1	257	0	2	322	2	326	0	2	0	3	5	0	0	0	2	2	590
Total Volume	0	32	1033	10	1075	0	15	1222	4	1241	0	4	0	13	17	0	8	1	12	21	2354
% App. Total	0	3	96.1	0.9		0	1.2	98.5	0.3		0	23.5	0	76.5		0	38.1	4.8	57.1		
PHF	.000	.667	.936	.417	.950	.000	.750	.949	.500	.952	.000	.500	.000	.813	.850	.000	.500	.250	.600	.583	.994

# Malaga Avenue at Le Jeune Rd

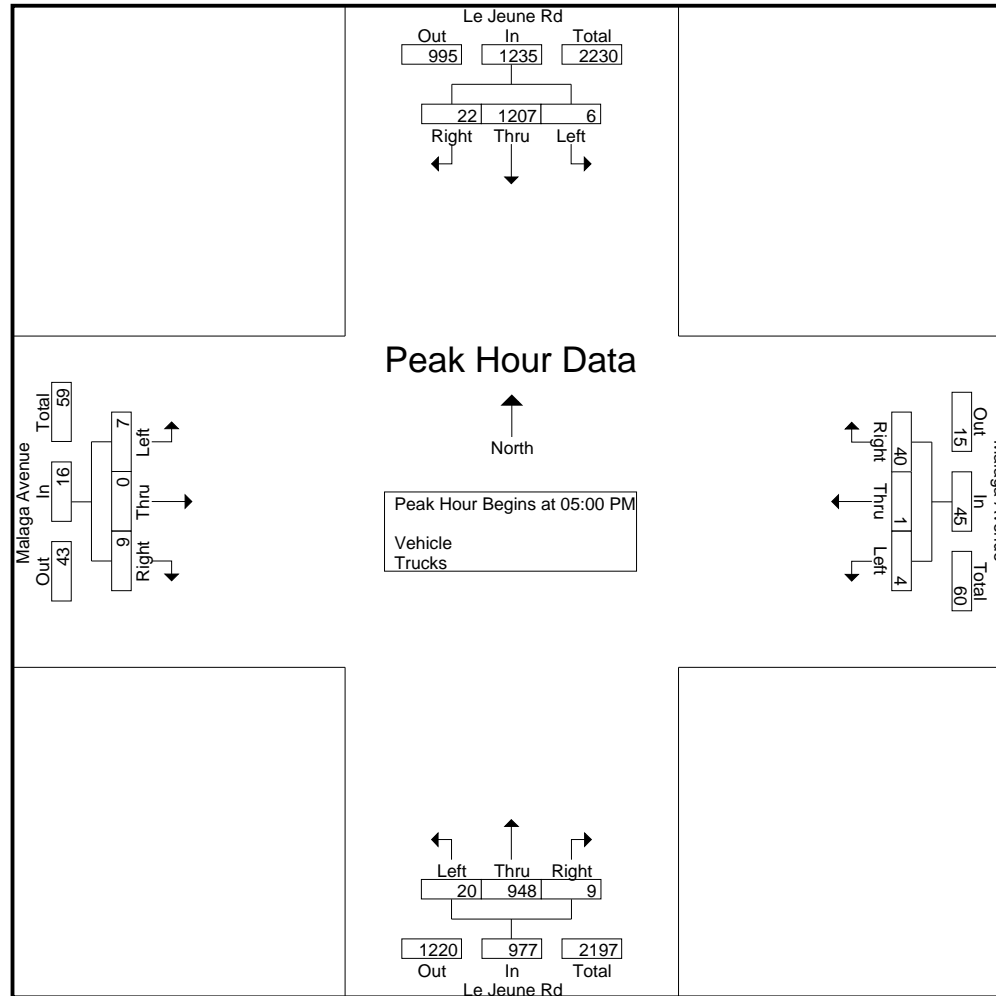
File Name : TMC-4 Malaga Avenue at Le Jeune Rd  
 Site Code : 00000000  
 Start Date : 8/31/2021  
 Page No : 4



# Malaga Avenue at Le Jeune Rd

File Name : TMC-4 Malaga Avenue at Le Jeune Rd  
 Site Code : 00000000  
 Start Date : 8/31/2021  
 Page No : 5

Start Time	Le Jeune Rd Southbound					Le Jeune Rd Northbound					Malaga Avenue Westbound					Malaga Avenue Eastbound					Int. Total
	U-Turns	Left	Thru	Right	App. Total	U-Turns	Left	Thru	Right	App. Total	U-Turns	Left	Thru	Right	App. Total	U-Turns	Left	Thru	Right	App. Total	
Peak Hour Analysis From 04:00 PM to 05:45 PM - Peak 1 of 1																					
Peak Hour for Entire Intersection Begins at 05:00 PM																					
05:00 PM	0	0	310	6	316	0	5	249	1	255	0	0	0	10	10	0	0	0	2	2	583
05:15 PM	0	2	285	8	295	0	5	280	3	288	0	2	0	13	15	0	2	0	1	3	601
05:30 PM	0	2	286	3	291	0	6	214	2	222	0	2	1	12	15	0	3	0	2	5	533
05:45 PM	0	2	326	5	333	0	4	205	3	212	0	0	0	5	5	0	2	0	4	6	556
Total Volume	0	6	1207	22	1235	0	20	948	9	977	0	4	1	40	45	0	7	0	9	16	2273
% App. Total	0	0.5	97.7	1.8		0	2	97	0.9		0	8.9	2.2	88.9		0	43.8	0	56.2		
PHF	.000	.750	.926	.688	.927	.000	.833	.846	.750	.848	.000	.500	.250	.769	.750	.000	.583	.000	.563	.667	.946



# Malaga Avenue at Le Jeune Rd

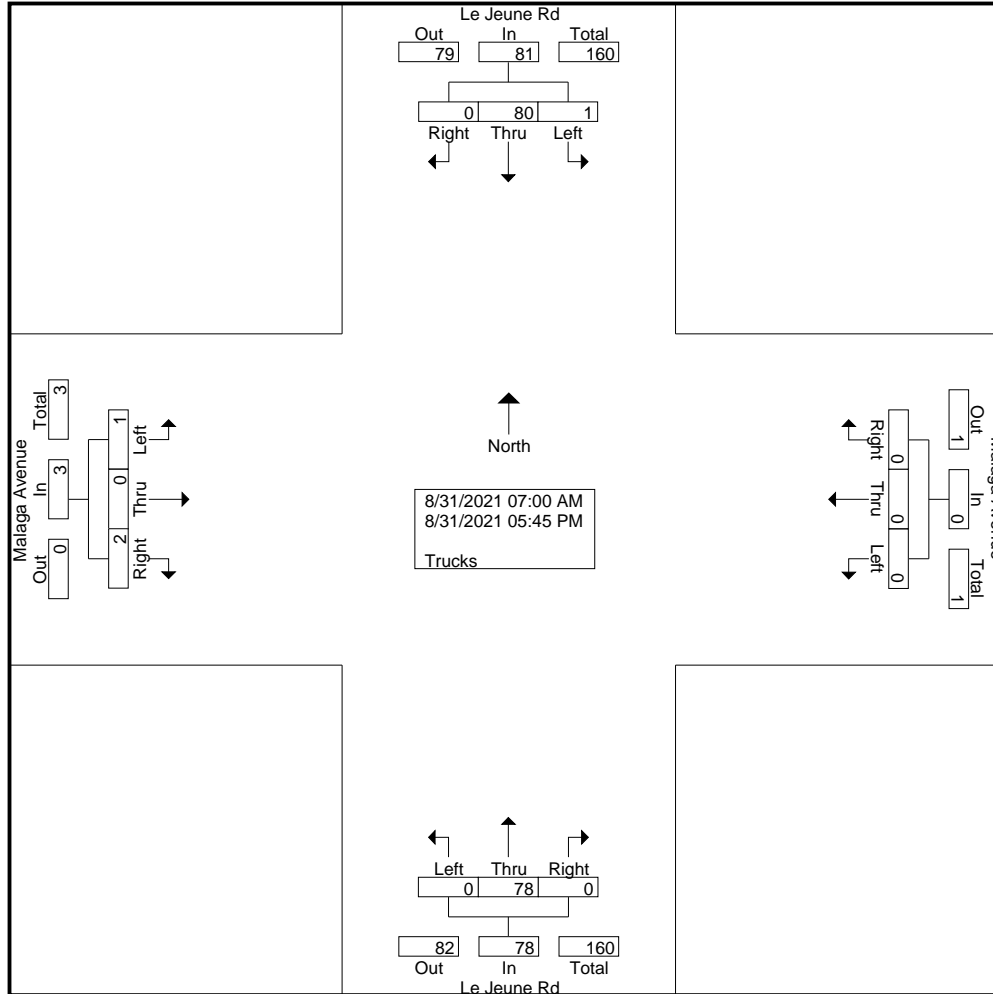
File Name : TMC-4 Malaga Avenue at Le Jeune Rd  
 Site Code : 00000000  
 Start Date : 8/31/2021  
 Page No : 1

**Groups Printed- Trucks**

Start Time	Le Jeune Rd Southbound					Le Jeune Rd Northbound					Malaga Avenue Westbound					Malaga Avenue Eastbound					Int. Total
	U-Turns	Left	Thru	Right	App. Total	U-Turns	Left	Thru	Right	App. Total	U-Turns	Left	Thru	Right	App. Total	U-Turns	Left	Thru	Right	App. Total	
07:00 AM	0	0	3	0	3	0	0	13	0	13	0	0	0	0	0	0	0	0	0	0	16
07:15 AM	0	0	9	0	9	0	0	3	0	3	0	0	0	0	0	0	0	0	0	0	12
07:30 AM	0	0	6	0	6	0	0	3	0	3	0	0	0	0	0	0	0	0	0	0	9
07:45 AM	0	0	6	0	6	0	0	6	0	6	0	0	0	0	0	0	0	0	0	0	12
<b>Total</b>	<b>0</b>	<b>0</b>	<b>24</b>	<b>0</b>	<b>24</b>	<b>0</b>	<b>0</b>	<b>25</b>	<b>0</b>	<b>25</b>	<b>0</b>	<b>0</b>	<b>0</b>	<b>0</b>	<b>0</b>	<b>0</b>	<b>0</b>	<b>0</b>	<b>0</b>	<b>0</b>	<b>49</b>
08:00 AM	0	0	5	0	5	0	0	1	0	1	0	0	0	0	0	0	0	0	0	0	6
08:15 AM	0	0	11	0	11	0	0	5	0	5	0	0	0	0	0	0	0	0	2	2	18
08:30 AM	0	0	10	0	10	0	0	4	0	4	0	0	0	0	0	0	0	0	0	0	14
08:45 AM	0	1	3	0	4	0	0	7	0	7	0	0	0	0	0	0	0	0	0	0	11
<b>Total</b>	<b>0</b>	<b>1</b>	<b>29</b>	<b>0</b>	<b>30</b>	<b>0</b>	<b>0</b>	<b>17</b>	<b>0</b>	<b>17</b>	<b>0</b>	<b>0</b>	<b>0</b>	<b>0</b>	<b>0</b>	<b>0</b>	<b>0</b>	<b>0</b>	<b>2</b>	<b>2</b>	<b>49</b>
*** BREAK ***																					
04:00 PM	0	0	4	0	4	0	0	3	0	3	0	0	0	0	0	0	0	0	0	0	7
04:15 PM	0	0	3	0	3	0	0	5	0	5	0	0	0	0	0	0	0	0	0	0	8
04:30 PM	0	0	6	0	6	0	0	4	0	4	0	0	0	0	0	0	0	0	0	0	10
04:45 PM	0	0	1	0	1	0	0	6	0	6	0	0	0	0	0	0	0	0	0	0	7
<b>Total</b>	<b>0</b>	<b>0</b>	<b>14</b>	<b>0</b>	<b>14</b>	<b>0</b>	<b>0</b>	<b>18</b>	<b>0</b>	<b>18</b>	<b>0</b>	<b>0</b>	<b>0</b>	<b>0</b>	<b>0</b>	<b>0</b>	<b>0</b>	<b>0</b>	<b>0</b>	<b>0</b>	<b>32</b>
05:00 PM	0	0	6	0	6	0	0	6	0	6	0	0	0	0	0	0	0	0	0	0	12
05:15 PM	0	0	1	0	1	0	0	7	0	7	0	0	0	0	0	0	0	0	0	0	8
05:30 PM	0	0	2	0	2	0	0	2	0	2	0	0	0	0	0	0	1	0	0	1	5
05:45 PM	0	0	4	0	4	0	0	3	0	3	0	0	0	0	0	0	0	0	0	0	7
<b>Total</b>	<b>0</b>	<b>0</b>	<b>13</b>	<b>0</b>	<b>13</b>	<b>0</b>	<b>0</b>	<b>18</b>	<b>0</b>	<b>18</b>	<b>0</b>	<b>0</b>	<b>0</b>	<b>0</b>	<b>0</b>	<b>0</b>	<b>1</b>	<b>0</b>	<b>0</b>	<b>1</b>	<b>32</b>
<b>Grand Total</b>	<b>0</b>	<b>1</b>	<b>80</b>	<b>0</b>	<b>81</b>	<b>0</b>	<b>0</b>	<b>78</b>	<b>0</b>	<b>78</b>	<b>0</b>	<b>0</b>	<b>0</b>	<b>0</b>	<b>0</b>	<b>0</b>	<b>1</b>	<b>0</b>	<b>2</b>	<b>3</b>	<b>162</b>
Apprch %	0	1.2	98.8	0		0	0	100	0		0	0	0	0		0	33.3	0	66.7		
Total %	0	0.6	49.4	0	50	0	0	48.1	0	48.1	0	0	0	0	0	0	0.6	0	1.2	1.9	

# Malaga Avenue at Le Jeune Rd

File Name : TMC-4 Malaga Avenue at Le Jeune Rd  
 Site Code : 00000000  
 Start Date : 8/31/2021  
 Page No : 2





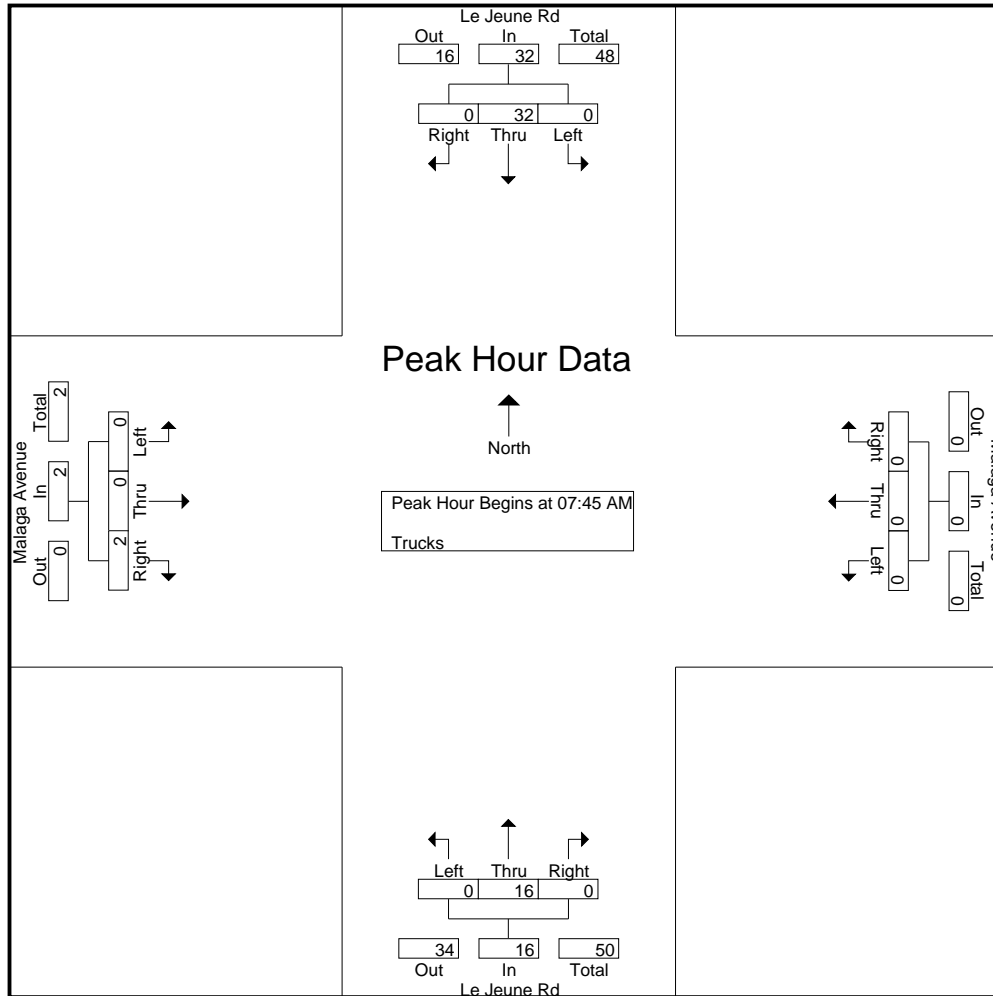
# Malaga Avenue at Le Jeune Rd

File Name : TMC-4 Malaga Avenue at Le Jeune Rd  
 Site Code : 00000000  
 Start Date : 8/31/2021  
 Page No : 3

Start Time	Le Jeune Rd Southbound					Le Jeune Rd Northbound					Malaga Avenue Westbound					Malaga Avenue Eastbound					Int. Total
	U-Turns	Left	Thru	Right	App. Total	U-Turns	Left	Thru	Right	App. Total	U-Turns	Left	Thru	Right	App. Total	U-Turns	Left	Thru	Right	App. Total	
Peak Hour Analysis From 07:00 AM to 08:45 AM - Peak 1 of 1																					
Peak Hour for Entire Intersection Begins at 07:45 AM																					
07:45 AM	0	0	6	0	6	0	0	6	0	6	0	0	0	0	0	0	0	0	0	0	12
08:00 AM	0	0	5	0	5	0	0	1	0	1	0	0	0	0	0	0	0	0	0	0	6
08:15 AM	0	0	11	0	11	0	0	5	0	5	0	0	0	0	0	0	0	0	2	2	18
08:30 AM	0	0	10	0	10	0	0	4	0	4	0	0	0	0	0	0	0	0	0	0	14
Total Volume	0	0	32	0	32	0	0	16	0	16	0	0	0	0	0	0	0	0	2	2	50
% App. Total	0	0	100	0		0	0	100	0		0	0	0	0		0	0	0	100		
PHF	.000	.000	.727	.000	.727	.000	.000	.667	.000	.667	.000	.000	.000	.000	.000	.000	.000	.000	.250	.250	.694

# Malaga Avenue at Le Jeune Rd

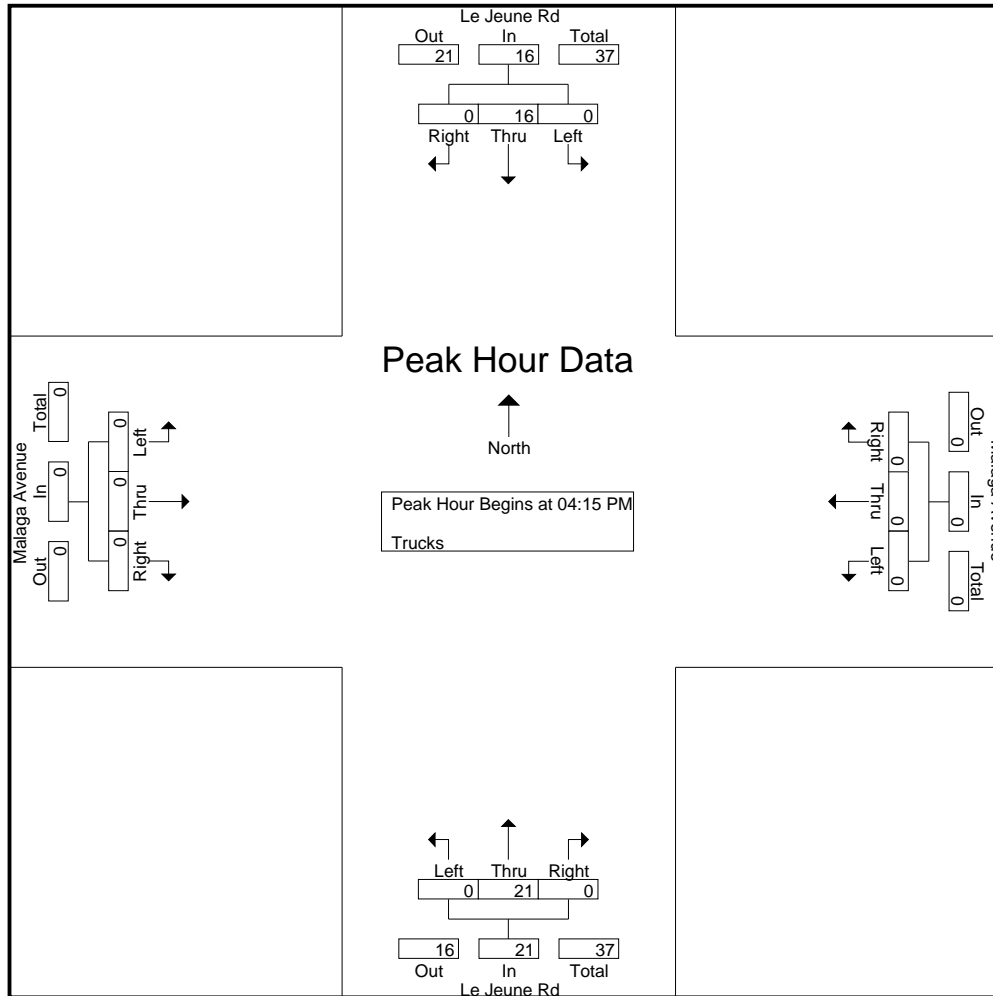
File Name : TMC-4 Malaga Avenue at Le Jeune Rd  
 Site Code : 00000000  
 Start Date : 8/31/2021  
 Page No : 4



# Malaga Avenue at Le Jeune Rd

File Name : TMC-4 Malaga Avenue at Le Jeune Rd  
 Site Code : 00000000  
 Start Date : 8/31/2021  
 Page No : 5

Start Time	Le Jeune Rd Southbound					Le Jeune Rd Northbound					Malaga Avenue Westbound					Malaga Avenue Eastbound					Int. Total	
	U-Turns	Left	Thru	Right	App. Total	U-Turns	Left	Thru	Right	App. Total	U-Turns	Left	Thru	Right	App. Total	U-Turns	Left	Thru	Right	App. Total		
Peak Hour Analysis From 04:00 PM to 05:45 PM - Peak 1 of 1																						
Peak Hour for Entire Intersection Begins at 04:15 PM																						
04:15 PM	0	0	3	0	3	0	0	5	0	5	0	0	0	0	0	0	0	0	0	0	0	8
04:30 PM	0	0	6	0	6	0	0	4	0	4	0	0	0	0	0	0	0	0	0	0	0	10
04:45 PM	0	0	1	0	1	0	0	6	0	6	0	0	0	0	0	0	0	0	0	0	0	7
05:00 PM	0	0	6	0	6	0	0	6	0	6	0	0	0	0	0	0	0	0	0	0	0	12
Total Volume	0	0	16	0	16	0	0	21	0	21	0	0	0	0	0	0	0	0	0	0	0	37
% App. Total	0	0	100	0		0	0	100	0		0	0	0	0		0	0	0	0			
PHF	.000	.000	.667	.000	.667	.000	.000	.875	.000	.875	.000	.000	.000	.000	.000	.000	.000	.000	.000	.000	.000	.771



# Malaga Avenue at Le Jeune Rd

File Name : TMC-4 Malaga Avenue at Le Jeune Rd  
 Site Code : 00000000  
 Start Date : 8/31/2021  
 Page No : 1

## Groups Printed- Peds & Bikes

Start Time	Le Jeune Rd Southbound			Le Jeune Rd Northbound			Malaga Avenue Westbound			Malaga Avenue Eastbound			Int. Total
	Peds	Bikes	App. Total	Peds	Bikes	App. Total	Peds	Bikes	App. Total	Peds	Bikes	App. Total	
07:00 AM	0	0	0	0	0	0	1	0	1	1	1	2	3
07:15 AM	1	0	1	0	0	0	1	1	2	1	1	2	5
07:30 AM	1	0	1	1	0	1	0	0	0	0	1	1	3
07:45 AM	1	0	1	0	0	0	2	0	2	0	0	0	3
<b>Total</b>	<b>3</b>	<b>0</b>	<b>3</b>	<b>1</b>	<b>0</b>	<b>1</b>	<b>4</b>	<b>1</b>	<b>5</b>	<b>2</b>	<b>3</b>	<b>5</b>	<b>14</b>
08:00 AM	0	1	1	0	0	0	0	0	0	0	0	0	1
08:15 AM	0	0	0	0	0	0	1	0	1	0	0	0	1
08:30 AM	1	0	1	0	0	0	0	0	0	0	0	0	1
*** BREAK ***													
<b>Total</b>	<b>1</b>	<b>1</b>	<b>2</b>	<b>0</b>	<b>0</b>	<b>0</b>	<b>1</b>	<b>0</b>	<b>1</b>	<b>0</b>	<b>0</b>	<b>0</b>	<b>3</b>
*** BREAK ***													
04:00 PM	0	0	0	0	0	0	1	0	1	1	0	1	2
04:45 PM	0	0	0	0	0	0	0	0	0	0	1	1	1
<b>Total</b>	<b>0</b>	<b>0</b>	<b>0</b>	<b>0</b>	<b>0</b>	<b>0</b>	<b>1</b>	<b>0</b>	<b>1</b>	<b>1</b>	<b>1</b>	<b>2</b>	<b>3</b>
05:00 PM	0	0	0	2	0	2	0	0	0	0	0	0	2
05:30 PM	0	0	0	2	0	2	0	0	0	0	0	0	2
*** BREAK ***													
<b>Total</b>	<b>0</b>	<b>0</b>	<b>0</b>	<b>4</b>	<b>0</b>	<b>4</b>	<b>0</b>	<b>0</b>	<b>0</b>	<b>0</b>	<b>0</b>	<b>0</b>	<b>4</b>
<b>Grand Total</b>	<b>4</b>	<b>1</b>	<b>5</b>	<b>5</b>	<b>0</b>	<b>5</b>	<b>6</b>	<b>1</b>	<b>7</b>	<b>3</b>	<b>4</b>	<b>7</b>	<b>24</b>
Apprch %	80	20		100	0		85.7	14.3		42.9	57.1		
Total %	16.7	4.2	20.8	20.8	0	20.8	25	4.2	29.2	12.5	16.7	29.2	

# Malaga Avenue at Le Jeune Rd

File Name : TMC-4 Malaga Avenue at Le Jeune Rd  
 Site Code : 00000000  
 Start Date : 8/31/2021  
 Page No : 3

Start Time	Le Jeune Rd Southbound			Le Jeune Rd Northbound			Malaga Avenue Westbound			Malaga Avenue Eastbound			Int. Total
	Peds	Bikes	App. Total	Peds	Bikes	App. Total	Peds	Bikes	App. Total	Peds	Bikes	App. Total	
Peak Hour Analysis From 07:00 AM to 08:45 AM - Peak 1 of 1													
Peak Hour for Entire Intersection Begins at 07:00 AM													
07:00 AM	0	0	0	0	0	0	1	0	1	1	1	2	3
07:15 AM	1	0	1	0	0	0	1	1	2	1	1	2	5
07:30 AM	1	0	1	1	0	1	0	0	0	0	1	1	3
07:45 AM	1	0	1	0	0	0	2	0	2	0	0	0	3
Total Volume	3	0	3	1	0	1	4	1	5	2	3	5	14
% App. Total	100	0		100	0		80	20		40	60		
PHF	.750	.000	.750	.250	.000	.250	.500	.250	.625	.500	.750	.625	.700

# Malaga Avenue at Le Jeune Rd

File Name : TMC-4 Malaga Avenue at Le Jeune Rd  
 Site Code : 00000000  
 Start Date : 8/31/2021  
 Page No : 5

Start Time	Le Jeune Rd Southbound			Le Jeune Rd Northbound			Malaga Avenue Westbound			Malaga Avenue Eastbound			Int. Total
	Peds	Bikes	App. Total	Peds	Bikes	App. Total	Peds	Bikes	App. Total	Peds	Bikes	App. Total	
Peak Hour Analysis From 04:00 PM to 05:45 PM - Peak 1 of 1													
Peak Hour for Entire Intersection Begins at 04:45 PM													
04:45 PM	0	0	0	0	0	0	0	0	0	0	1	1	1
05:00 PM	0	0	0	2	0	2	0	0	0	0	0	0	2
05:15 PM	0	0	0	0	0	0	0	0	0	0	0	0	0
05:30 PM	0	0	0	2	0	2	0	0	0	0	0	0	2
Total Volume	0	0	0	4	0	4	0	0	0	0	1	1	5
% App. Total	0	0	0	100	0	100	0	0	0	0	100	100	100
PHF	.000	.000	.000	.500	.000	.500	.000	.000	.000	.000	.250	.250	.625

## Field Review Pictures



***Le Jeune Road at University Drive, East Leg (Facing West):*** No residual queues after green time ends.



***Le Jeune Road at University Drive, East Leg (Facing East):*** Longest observed queues were of 10 vehicles in the westbound direction





***Le Jeune Road at University Drive, North Leg (Facing South):*** Permissive phase along Le Jeune Road functions smoothly as turning vehicles can often find gaps in through traffic.



***Catalonia Ave and Salzedo Street (Facing East):*** Low volumes in all approach during the PM peak period.



***Malaga Avenue (Facing East):*** Westbound approach presents very low volume of traffic but high utilization of on-street parking.

# **Appendix C**

## Growth Factor Calculations

## FDOT Sites Information

FLORIDA DEPARTMENT OF TRANSPORTATION  
 TRANSPORTATION STATISTICS OFFICE  
 2020 HISTORICAL AADT REPORT

COUNTY: 87 - MIAMI-DADE

SITE: 0024 - SR 953/LEJEUNE RD, 200' S CORAL WAY/SR 972

YEAR	AADT		DIRECTION 1		DIRECTION 2	*K FACTOR	D FACTOR	T FACTOR
2020	27000	C	N 15000		S 12000	9.00	56.00	4.70
2019	32000	C	N 17000		S 15000	9.00	56.00	5.80
2018	32500	C	N 17500		S 15000	9.00	54.30	6.10
2017	31500	C	N 18500		S 13000	9.00	54.00	7.00
2016	36000	C	N 18000		S 18000	9.00	56.10	4.90
2015	35500	C	N 16500		S 19000	9.00	57.40	4.60
2014	44500	C	N 23500		S 21000	9.00	59.30	5.90
2013	34000	C	N 18000		S 16000	9.00	58.90	5.70
2012	35500	C	N 18000		S 17500	9.00	59.70	4.00
2011	35500	C	N 18000		S 17500	9.00	58.20	5.70
2010	44500	C	N 22000		S 22500	7.87	58.27	3.80
2009	43000	C	N 22500		S 20500	7.98	59.96	3.20
2008	45000	C	N 23500		S 21500	8.07	66.31	3.50
2007	42000	C	N 22000		S 20000	7.90	63.12	4.70
2006	34000	C	N 15000		S 19000	7.39	58.66	7.20
2005	48000	F	N 21500		S 26500	7.70	65.70	5.50

AADT FLAGS: C = COMPUTED; E = MANUAL ESTIMATE; F = FIRST YEAR ESTIMATE  
 S = SECOND YEAR ESTIMATE; T = THIRD YEAR ESTIMATE; R = FOURTH YEAR ESTIMATE  
 V = FIFTH YEAR ESTIMATE; 6 = SIXTH YEAR ESTIMATE; X = UNKNOWN

\*K FACTOR: STARTING WITH YEAR 2011 IS STANDARDK, PRIOR YEARS ARE K30 VALUES

FLORIDA DEPARTMENT OF TRANSPORTATION  
 TRANSPORTATION STATISTICS OFFICE  
 2020 HISTORICAL AADT REPORT

COUNTY: 87 - MIAMI-DADE

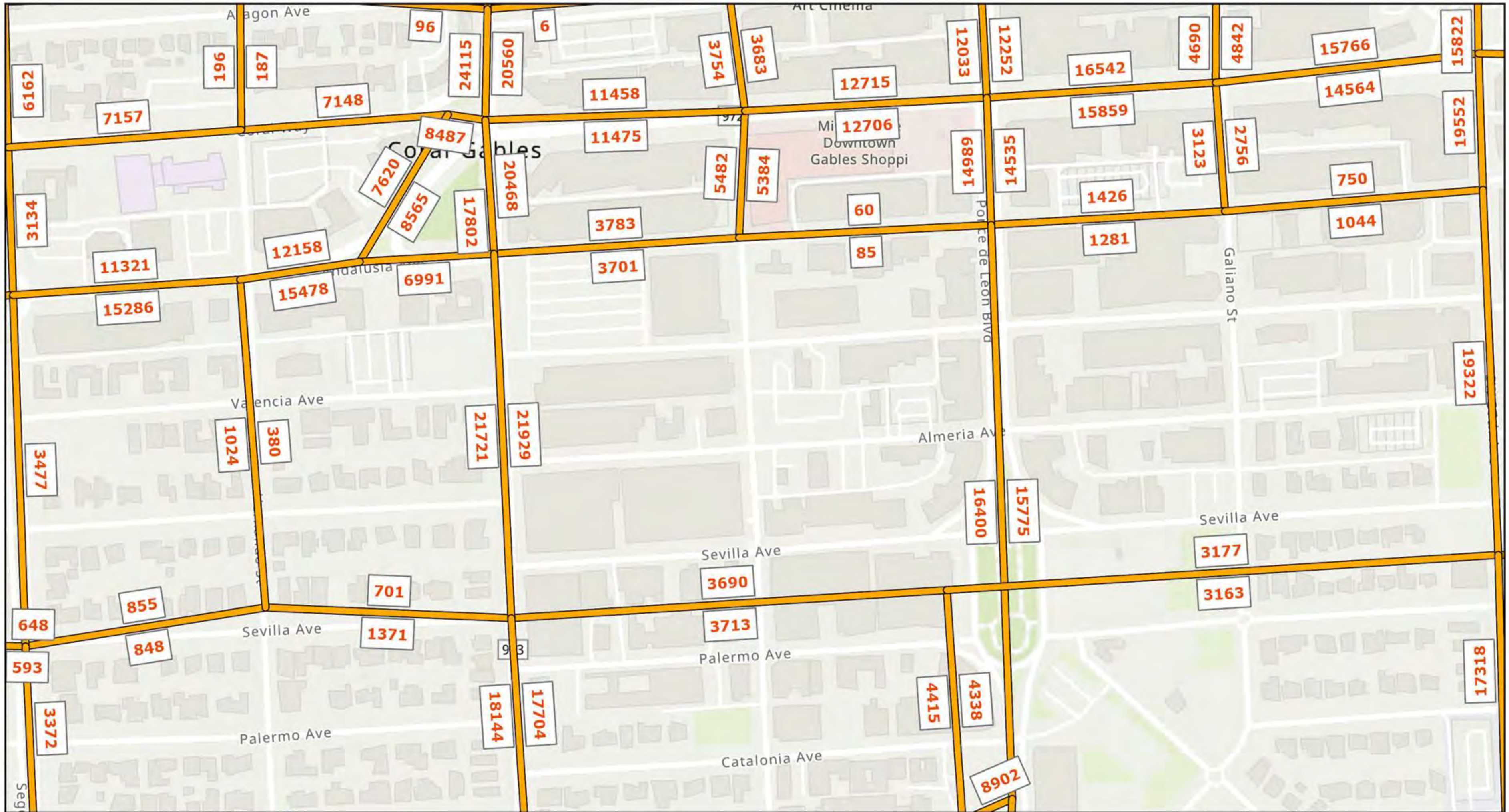
SITE: 2534 - SR 972/CORAL WAY, 200' E SW 37 AVENUE

YEAR	AADT		DIRECTION 1		DIRECTION 2	*K FACTOR	D FACTOR	T FACTOR
2020	26000	C	E 12500		W 13500	9.00	56.00	1.40
2019	32500	C	E 15500		W 17000	9.00	56.00	3.90
2018	32500	C	E 15500		W 17000	9.00	54.30	6.00
2017	30000	C	E 12500		W 17500	9.00	55.70	4.40
2016	42000	C	E 21000		W 21000	9.00	56.10	3.50
2015	35500	C	E 16000		W 19500	9.00	57.40	5.90
2014	41500	C	E 22000		W 19500	9.00	59.30	10.00
2013	37000	C	E 17000		W 20000	9.00	58.90	2.20
2012	36000	C	E 18000		W 18000	9.00	59.70	2.00
2011	42500	C	E 21000		W 21500	9.00	58.20	3.30
2010	43000	C	E 21000		W 22000	7.87	58.27	4.10
2009	38000	C	E 19000		W 19000	7.98	59.96	2.90
2008	37000	C	E 17500		W 19500	8.07	66.31	2.40
2007	40500	C	E 19000		W 21500	7.90	63.12	1.40
2006	40500	C	E 18500		W 22000	7.39	58.66	2.00
2005	44000	C	E 20000		W 24000	7.70	65.70	2.40


AADT FLAGS: C = COMPUTED; E = MANUAL ESTIMATE; F = FIRST YEAR ESTIMATE  
 S = SECOND YEAR ESTIMATE; T = THIRD YEAR ESTIMATE; R = FOURTH YEAR ESTIMATE  
 V = FIFTH YEAR ESTIMATE; 6 = SIXTH YEAR ESTIMATE; X = UNKNOWN

\*K FACTOR: STARTING WITH YEAR 2011 IS STANDARDK, PRIOR YEARS ARE K30 VALUES

# SERPM 8.0 Model Traffic Data



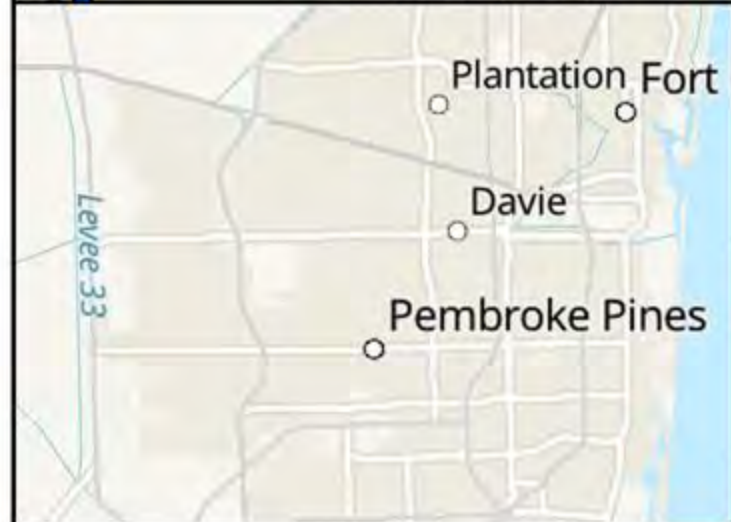
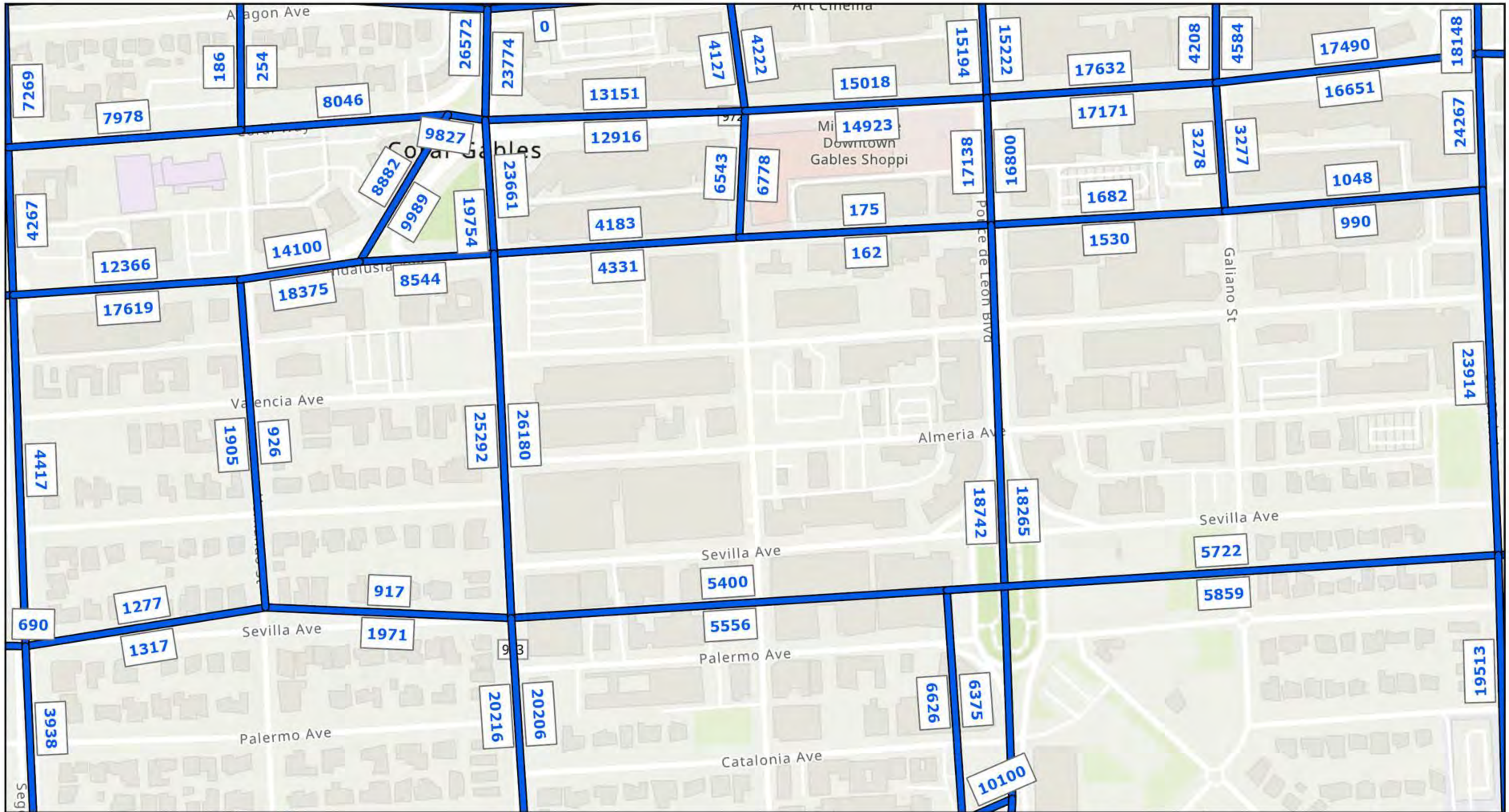
# SERPM 8 Forecasts

 SERPM 8 Forecasted AADT (2015)




Coordinate System: NAD 1983 2011 StatePlane Florida East FIPS 0901 Ft US





# SERPM 8 Forecasts

 SERPM 8 Forecasted AADT (2045)

Coordinate System: NAD 1983 2011 StatePlane Florida East FIPS 0901 Ft US



# FDOT Trends Spreadsheet Outputs

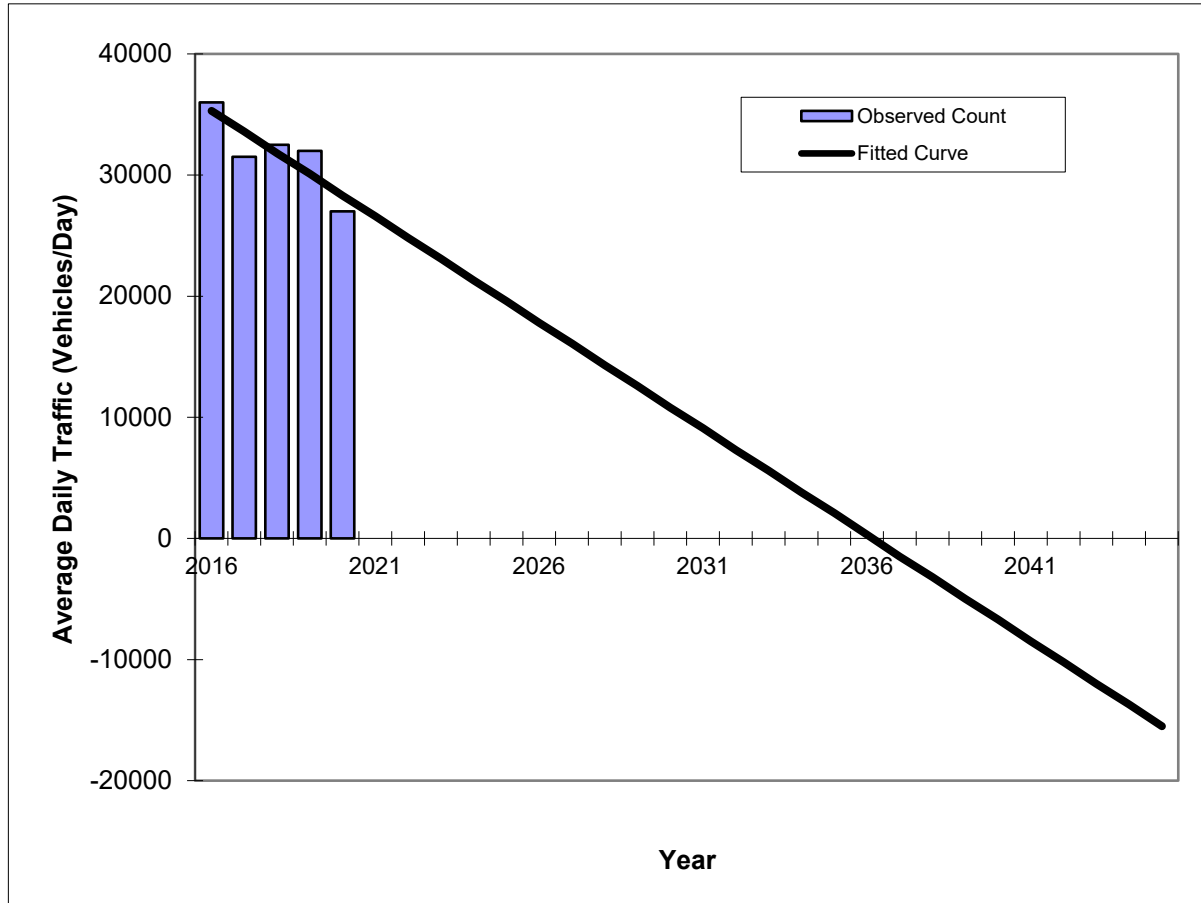
## Site 87-0024

## Traffic Trends - V03.a

### SR 953/LEJEUNE RD --

FIN#	00000000
Location	1

County:	Miami-Dade (87)
Station #:	0024
Highway:	SR 953/LEJEUNE RD



Year	Traffic (ADT/AADT)	
	Count*	Trend**
2016	36000	35300
2017	31500	33600
2018	32500	31800
2019	32000	30100
2020	27000	28300
<b>2025 Opening Year Trend</b>		
2025	N/A	19600
<b>2035 Mid-Year Trend</b>		
2035	N/A	2100
<b>2045 Design Year Trend</b>		
2045	N/A	-15500
<b>TRANPLAN Forecasts/Trends</b>		

** Annual Trend Increase:	-1,750
Trend R-squared:	74.15%
Trend Annual Historic Growth Rate:	-4.96%
Trend Growth Rate (2020 to Design Year):	-6.19%
Printed:	8-Sep-21
<b>Straight Line Growth Option</b>	

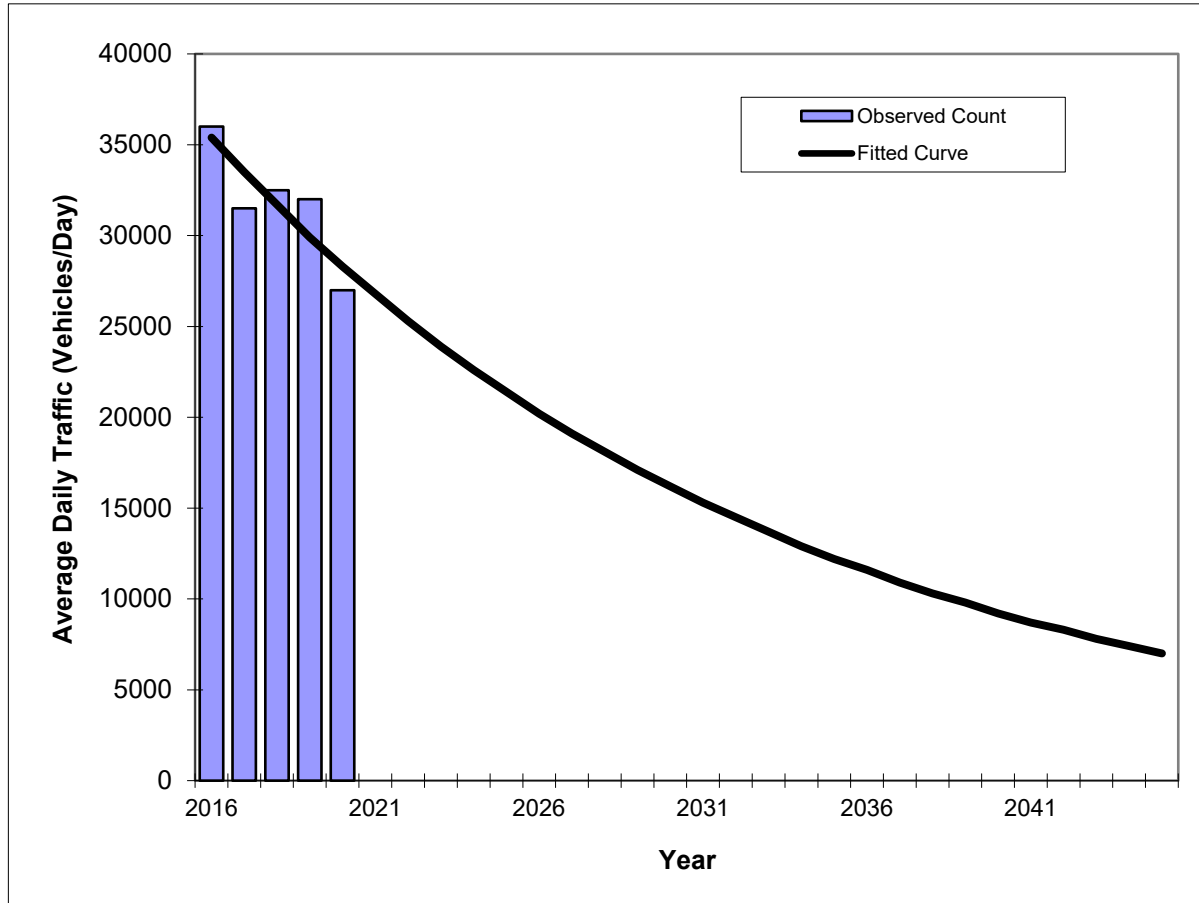
\*Axle-Adjusted

## Traffic Trends - V03.a

### SR 953/LEJEUNE RD --

FIN#	00000000
Location	1

County:	Miami-Dade (87)
Station #:	0024
Highway:	SR 953/LEJEUNE RD



Year	Traffic (ADT/AADT)	
	Count*	Trend**
2016	36000	35400
2017	31500	33500
2018	32500	31700
2019	32000	29900
2020	27000	28300
<b>2025 Opening Year Trend</b>		
2025	N/A	21400
<b>2035 Mid-Year Trend</b>		
2035	N/A	12200
<b>2045 Design Year Trend</b>		
2045	N/A	7000
<b>TRANPLAN Forecasts/Trends</b>		

Trend R-squared:	73.38%
Compounded Annual Historic Growth Rate:	-5.44%
Compounded Growth Rate (2020 to Design Year):	-5.43%
Printed:	8-Sep-21
<b>Exponential Growth Option</b>	

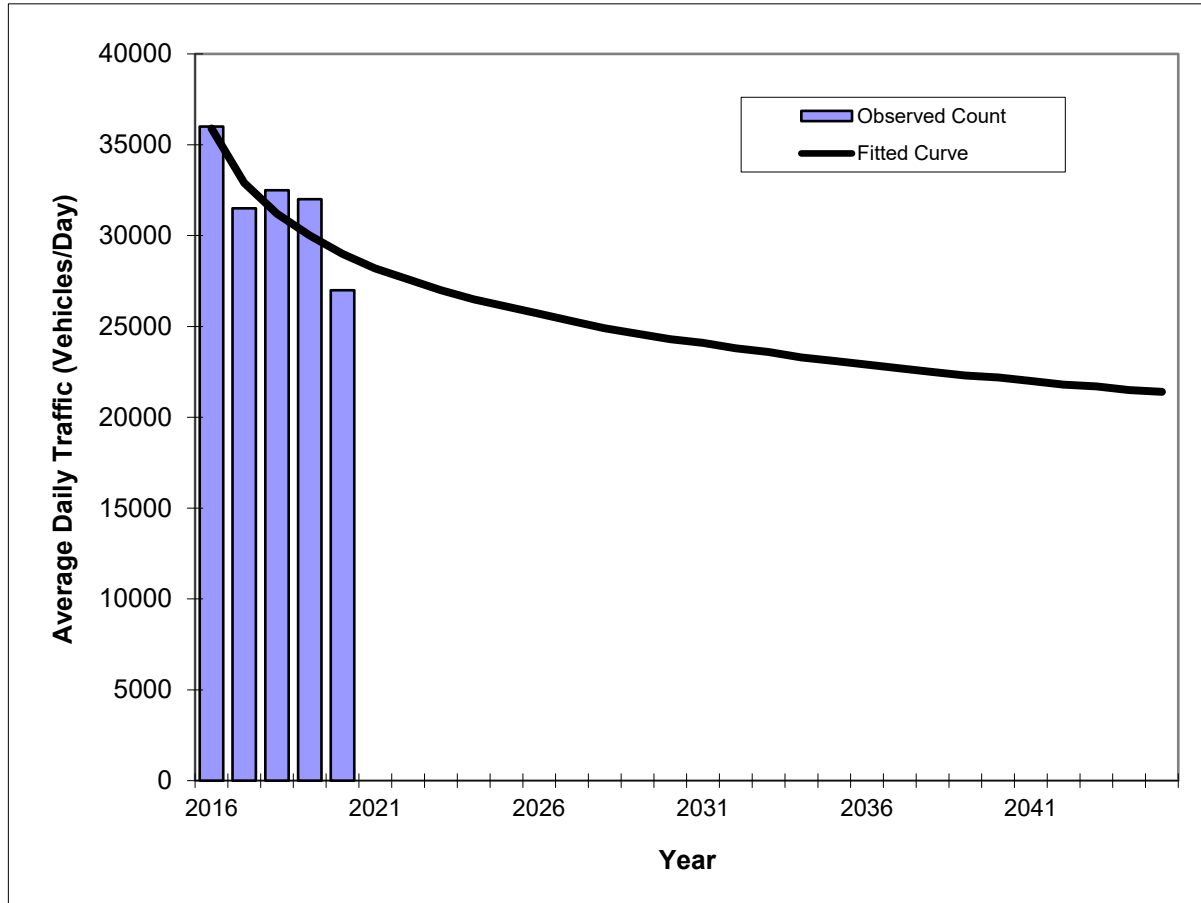
\*Axle-Adjusted

## Traffic Trends - V03.a

### SR 953/LEJEUNE RD --

FIN#	00000000
Location	1

County:	Miami-Dade (87)
Station #:	0024
Highway:	SR 953/LEJEUNE RD



Year	Traffic (ADT/AADT)	
	Count*	Trend**
2016	36000	35900
2017	31500	32900
2018	32500	31200
2019	32000	30000
2020	27000	29000
<b>2025 Opening Year Trend</b>		
2025	N/A	26100
<b>2035 Mid-Year Trend</b>		
2035	N/A	23100
<b>2045 Design Year Trend</b>		
2045	N/A	21400
<b>TRANPLAN Forecasts/Trends</b>		

Trend R-squared:	71.09%
Compounded Annual Historic Growth Rate:	-5.20%
Compounded Growth Rate (2020 to Design Year):	-1.21%
Printed:	8-Sep-21
<b>Decaying Exponential Growth Option</b>	

\*Axle-Adjusted

# FDOT Trends Spreadsheet Outputs

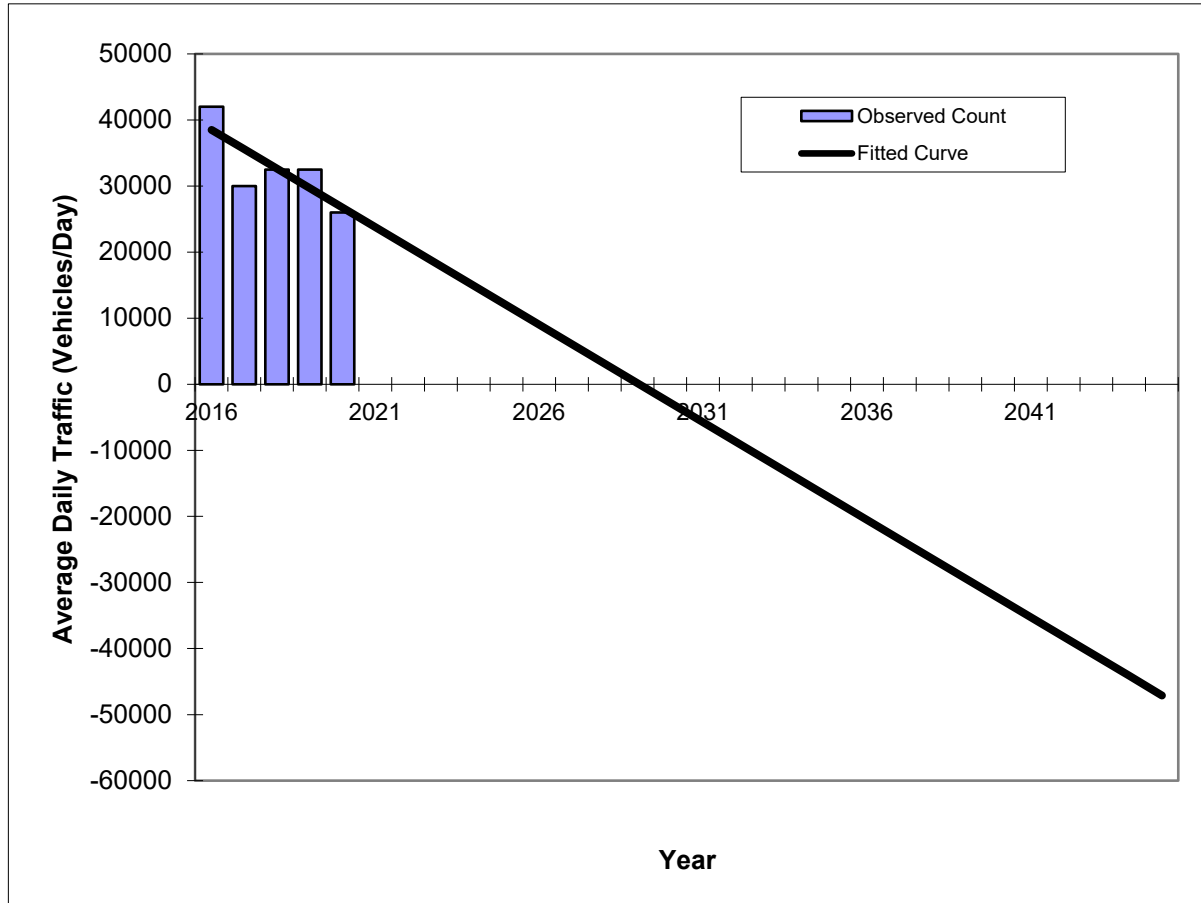
## Site 87-2535

## Traffic Trends - V03.a

### SR 972/CORAL WAY --

FIN#	00000000
Location	2

County:	Miami-Dade (87)
Station #:	2534
Highway:	SR 972/CORAL WAY



Year	Traffic (ADT/AADT)	
	Count*	Trend**
2016	42000	38500
2017	30000	35600
2018	32500	32600
2019	32500	29700
2020	26000	26700
<b>2025 Opening Year Trend</b>		
2025	N/A	12000
<b>2035 Mid-Year Trend</b>		
2035	N/A	-17600
<b>2045 Design Year Trend</b>		
2045	N/A	-47100
<b>TRANPLAN Forecasts/Trends</b>		

** Annual Trend Increase:	-2,950
Trend R-squared:	62.74%
Trend Annual Historic Growth Rate:	-7.66%
Trend Growth Rate (2020 to Design Year):	-11.06%
Printed:	9-Sep-21
<b>Straight Line Growth Option</b>	

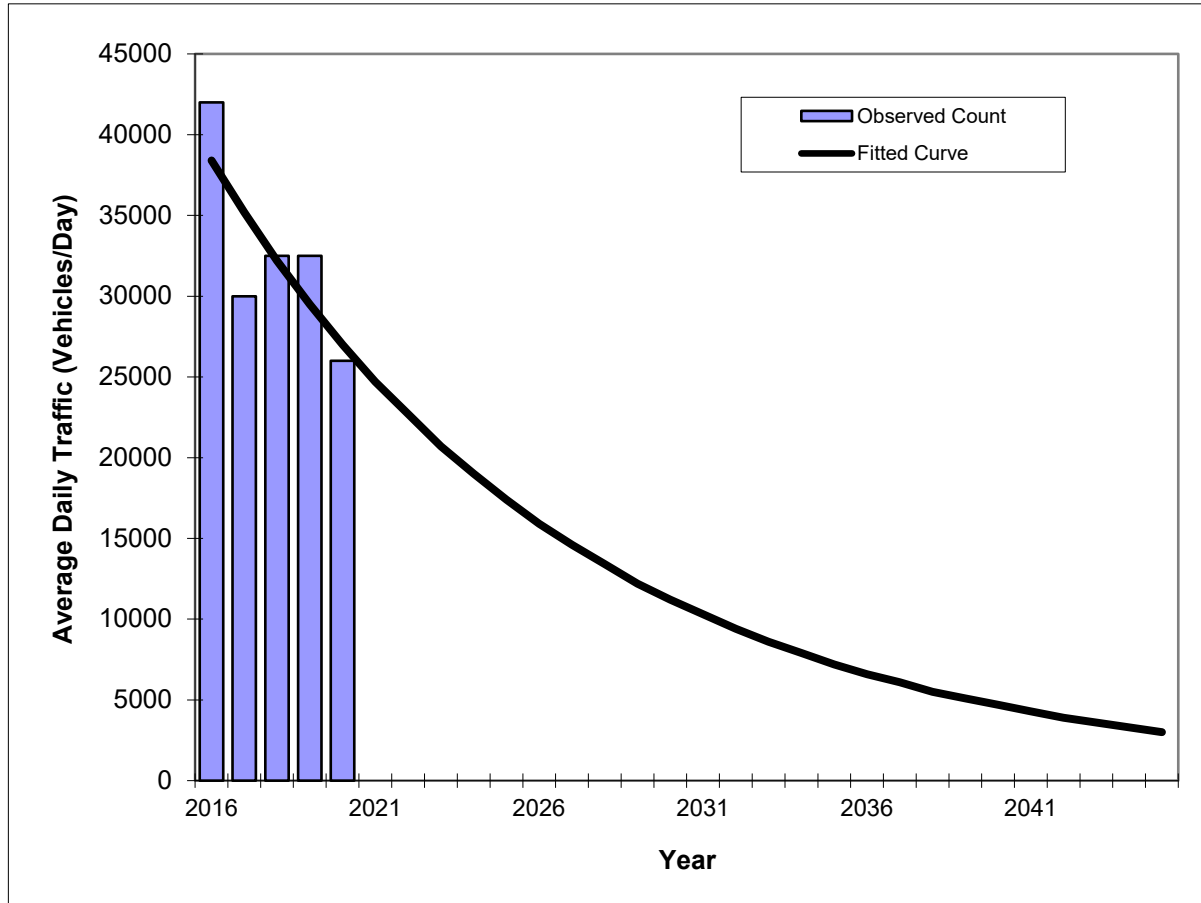
\*Axle-Adjusted

## Traffic Trends - V03.a

### SR 972/CORAL WAY --

FIN#	00000000
Location	2

County:	Miami-Dade (87)
Station #:	2534
Highway:	SR 972/CORAL WAY



Year	Traffic (ADT/AADT)	
	Count*	Trend**
2016	42000	38400
2017	30000	35200
2018	32500	32200
2019	32500	29500
2020	26000	27000
<b>2025 Opening Year Trend</b>		
2025	N/A	17400
<b>2035 Mid-Year Trend</b>		
2035	N/A	7200
<b>2045 Design Year Trend</b>		
2045	N/A	3000
<b>TRANPLAN Forecasts/Trends</b>		

Trend R-squared:	63.60%
Compounded Annual Historic Growth Rate:	-8.43%
Compounded Growth Rate (2020 to Design Year):	-8.41%
Printed:	9-Sep-21
<b>Exponential Growth Option</b>	

\*Axle-Adjusted

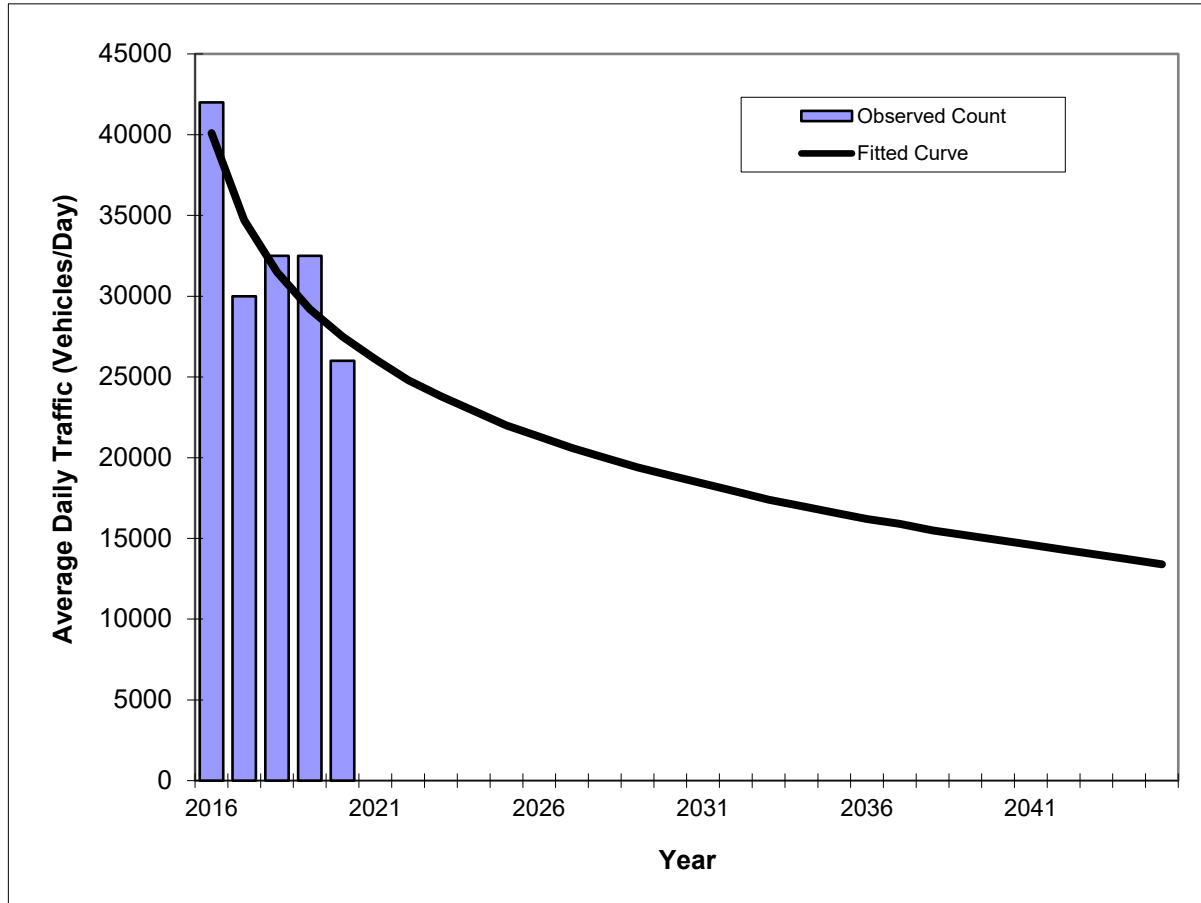


## Traffic Trends - V03.a

### SR 972/CORAL WAY --

FIN#	00000000
Location	2

County:	Miami-Dade (87)
Station #:	2534
Highway:	SR 972/CORAL WAY



Year	Traffic (ADT/AADT)	
	Count*	Trend**
2016	42000	40100
2017	30000	34700
2018	32500	31500
2019	32500	29200
2020	26000	27500
<b>2025 Opening Year Trend</b>		
2025	N/A	22000
<b>2035 Mid-Year Trend</b>		
2035	N/A	16600
<b>2045 Design Year Trend</b>		
2045	N/A	13400
<b>TRANPLAN Forecasts/Trends</b>		

Trend R-squared:	71.68%
Compounded Annual Historic Growth Rate:	-9.00%
Compounded Growth Rate (2020 to Design Year):	-2.83%
Printed:	9-Sep-21
<b>Decaying Exponential Growth Option</b>	

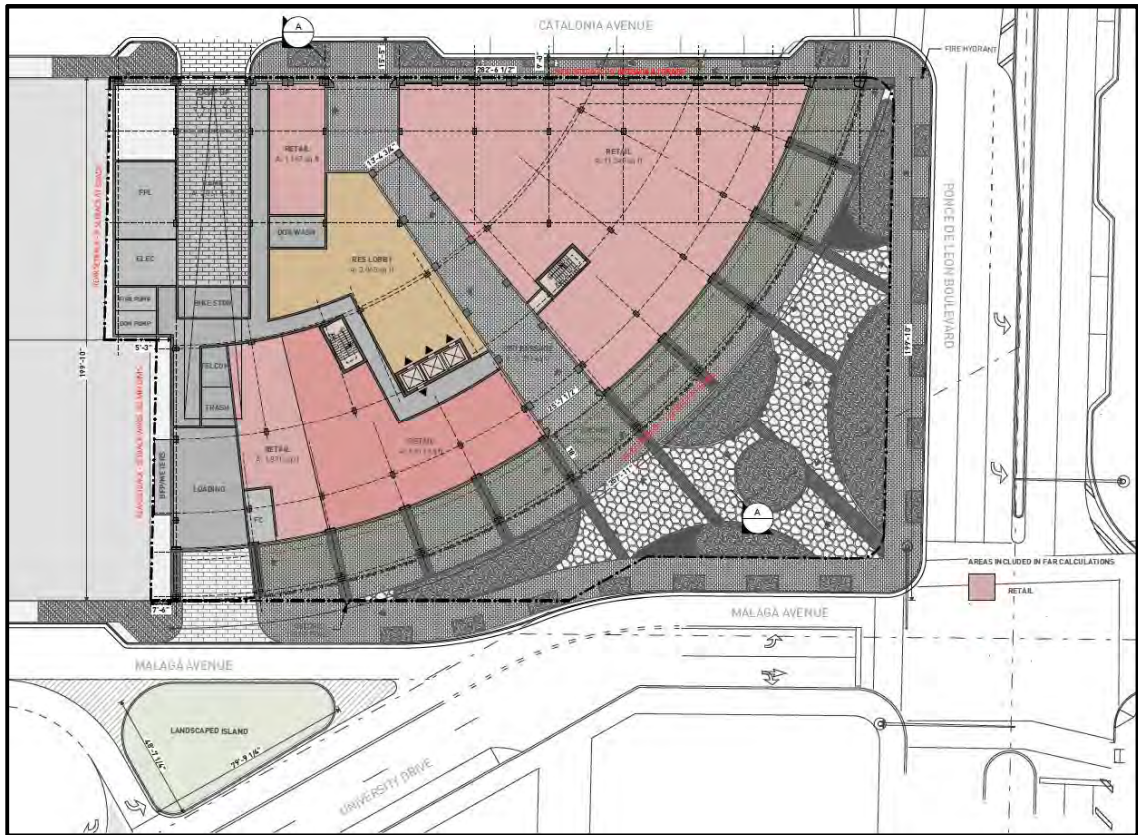
\*Axle-Adjusted

# Committed Development Information



*Traffic Impact Analysis  
for Submittal to  
the City of Coral Gables*

# Ponce Park Tower Coral Gables, Florida



**Kimley»Horn**

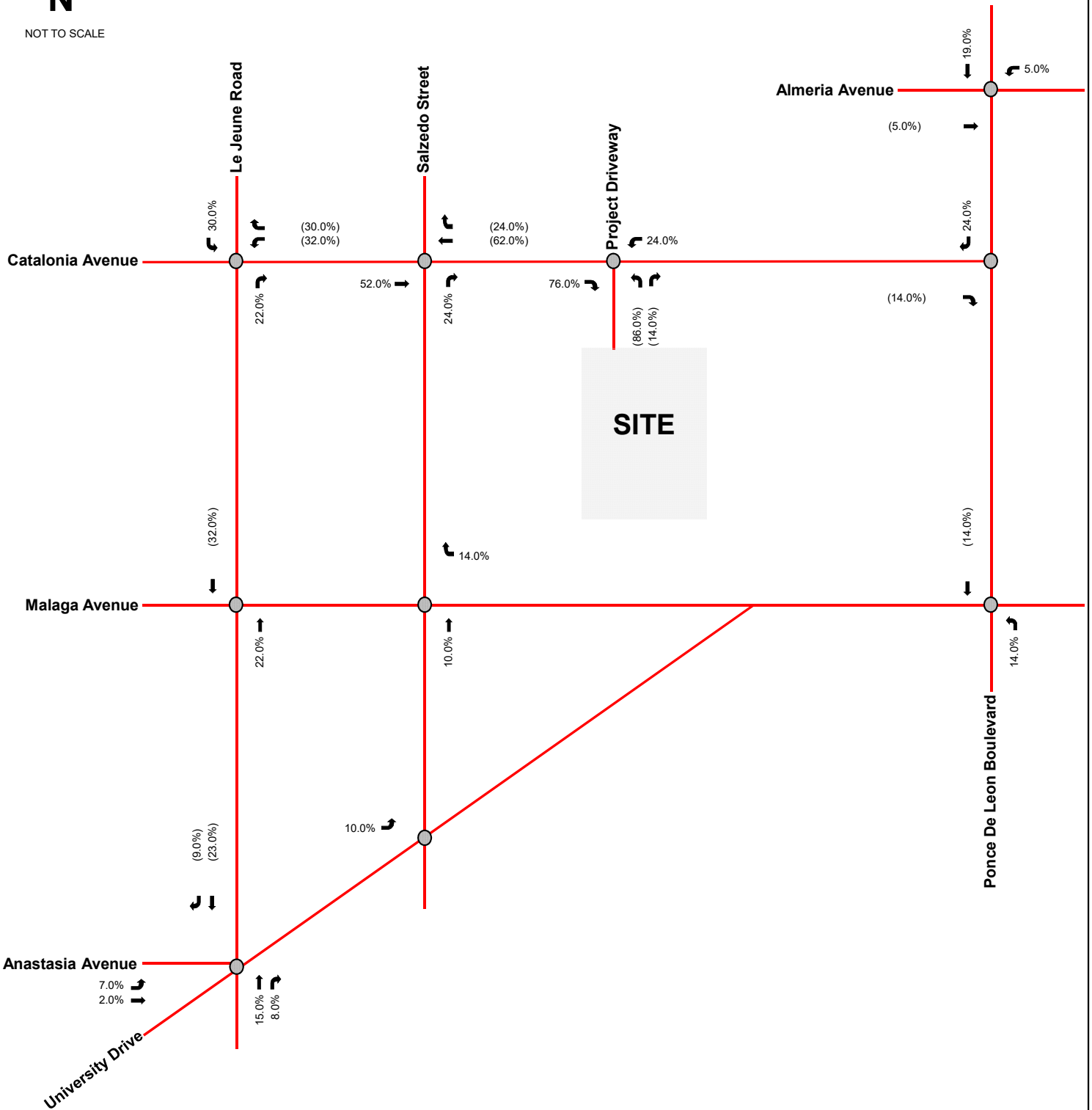
©2020 Kimley-Horn and Associates, Inc.  
November 2020  
143002008

**Legend**

- Study Roadway
- Study Intersection
- XX% Entering Trip Distribution
- (XX%) Exiting Trip Distribution





NOT TO SCALE

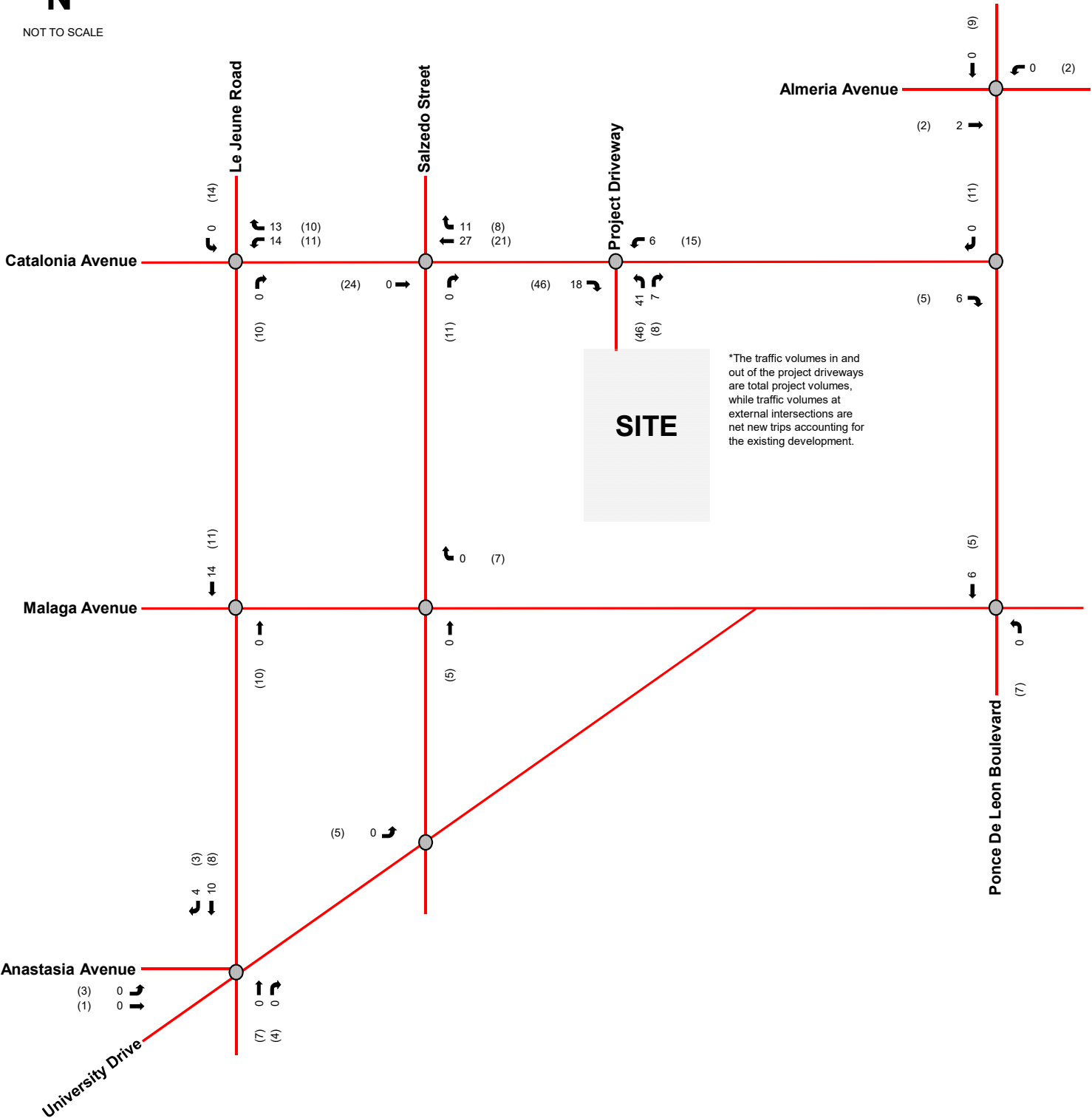




NOT TO SCALE

**Legend**

-  Study Roadway
-  Study Intersection
- XX A.M. Peak Hour Trip Assignment
- (XX) P.M. Peak Hour Trip Assignment



\*The traffic volumes in and out of the project driveways are total project volumes, while traffic volumes at external intersections are net new trips accounting for the existing development.

# TRAFFIC VOLUMES AT STUDY INTERSECTIONS

**INTERSECTION:** Catalonia Avenue and SW 42nd Avenue  
**COUNT DATE:** October 14, 2020  
**AM PEAK HOUR FACTOR:** 0.91  
**PM PEAK HOUR FACTOR:** 0.97

"AM EXISTING TRAFFIC"																	
	EBU	EBL	EBT	EBR	WBU	WBL	WBT	WBR	NBU	NBL	NBT	NBR	SBU	SBL	SBT	SBR	
AM Raw Turning Movements		10	0	20		2	0	17		16	965	15		77	951	2	
Peak Season Correction Factor	1.020	1.020	1.020	1.020	1.020	1.020	1.020	1.020	1.020	1.020	1.020	1.020	1.020	1.020	1.020	1.020	
Adjustment Factor	1.23	1.23	1.23	1.23	1.23	1.23	1.23	1.23	1.23	1.23	1.23	1.23	1.23	1.23	1.23	1.23	
<b>AM EXISTING CONDITIONS</b>		13	0	25		3	0	21		20	1,211	19		97	1,193	3	
"PM EXISTING TRAFFIC"																	
	EBU	EBL	EBT	EBR	WBU	WBL	WBT	WBR	NBU	NBL	NBT	NBR	SBU	SBL	SBT	SBR	
PM Raw Turning Movements		4	0	4		19	0	59		28	802	4		36	1,024	10	
Peak Season Correction Factor	1.020	1.020	1.020	1.020	1.020	1.020	1.020	1.020	1.020	1.020	1.020	1.020	1.020	1.020	1.020	1.020	
Adjustment Factor	1.23	1.23	1.23	1.23	1.23	1.23	1.23	1.23	1.23	1.23	1.23	1.23	1.23	1.23	1.23	1.23	
<b>PM EXISTING CONDITIONS</b>		5	0	5		24	0	74		35	1,006	5		45	1,285	13	
"AM BACKGROUND TRAFFIC"																	
PDL Blvd and Malaga Ave Signal Imp	EBU	EBL	EBT	EBR	WBU	WBL	WBT	WBR	NBU	NBL	NBT	NBR	SBU	SBL	SBT	SBR	
PDL Median																	
The Plaza Coral Gables											20				5		
<b>TOTAL "VESTED" TRAFFIC</b>		0	0	0		0	0	0		0	20	0		0	5	0	
Years To Buildout	2	2	2	2	2	2	2	2	2	2	2	2	2	2	2	2	
Yearly Growth Rate	0.51%	0.51%	0.51%	0.51%	0.51%	0.51%	0.51%	0.51%	0.51%	0.51%	0.51%	0.51%	0.51%	0.51%	0.51%	0.51%	
<b>AM BACKGROUND TRAFFIC GROWTH</b>		0	0	0		0	0	0		0	12	0		1	12	0	
<b>AM NON-PROJECT TRAFFIC</b>		13	0	25		3	0	21		20	1,243	19		98	1,210	3	
"PM BACKGROUND TRAFFIC"																	
PDL Blvd and Malaga Ave Signal Imp	EBU	EBL	EBT	EBR	WBU	WBL	WBT	WBR	NBU	NBL	NBT	NBR	SBU	SBL	SBT	SBR	
PDL Median																	
The Plaza Coral Gables											13				23		
<b>TOTAL "VESTED" TRAFFIC</b>		0	0	0		0	0	0		0	13	0		0	23	0	
Years To Buildout	2	2	2	2	2	2	2	2	2	2	2	2	2	2	2	2	
Yearly Growth Rate	0.51%	0.51%	0.51%	0.51%	0.51%	0.51%	0.51%	0.51%	0.51%	0.51%	0.51%	0.51%	0.51%	0.51%	0.51%	0.51%	
<b>PM BACKGROUND TRAFFIC GROWTH</b>		0	0	0		0	0	1		0	10	0		0	13	0	
<b>PM NON-PROJECT TRAFFIC</b>		5	0	5		24	0	75		35	1,029	5		45	1,321	13	
"AM PROJECT DISTRIBUTION"																	
LAND USE	TYPE	EBU	EBL	EBT	EBR	WBU	WBL	WBT	WBR	NBU	NBL	NBT	NBR	SBU	SBL	SBT	SBR
Pass-By Distribution	Entering																
	Exiting																
Valet Distribution	Entering																
	Exiting																
Net New Distribution	Entering												22.0%		30.0%		
	Exiting						32.0%		30.0%								
"PM PROJECT DISTRIBUTION"																	
LAND USE	TYPE	EBU	EBL	EBT	EBR	WBU	WBL	WBT	WBR	NBU	NBL	NBT	NBR	SBU	SBL	SBT	SBR
Pass-By Distribution	Entering																
	Exiting																
Valet Distribution	Entering																
	Exiting																
Net New Distribution	Entering												22.0%		30.0%		
	Exiting						32.0%		30.0%								
"AM PROJECT TRAFFIC"																	
LAND USE	TYPE	EBU	EBL	EBT	EBR	WBU	WBL	WBT	WBR	NBU	NBL	NBT	NBR	SBU	SBL	SBT	SBR
<b>AM TRAFFIC DIVERSIONS</b>																	
Project Trips	Pass - By																
	Valet																
	Net New						14		13				0		0		
<b>AM TOTAL PROJECT TRAFFIC</b>		0	0	0		14	0	13		0	0	0		0	0	0	
<b>AM TOTAL TRAFFIC</b>		13	0	25		17	0	34		20	1,243	19		98	1,210	3	
"PM PROJECT TRAFFIC"																	
LAND USE	TYPE	EBU	EBL	EBT	EBR	WBU	WBL	WBT	WBR	NBU	NBL	NBT	NBR	SBU	SBL	SBT	SBR
<b>PM TRAFFIC DIVERSIONS</b>																	
Project Trips	Pass - By																
	Valet																
	Net New						11		10				10		14		
<b>PM TOTAL PROJECT TRAFFIC</b>		0	0	0		11	0	10		0	0	10		14	0	0	
<b>PM TOTAL TRAFFIC</b>		5	0	5		35	0	85		35	1,029	15		59	1,321	13	

# TRAFFIC VOLUMES AT STUDY INTERSECTIONS

**INTERSECTION:** Catalonia Avenue and Salzedo Street  
**COUNT DATE:** October 14, 2020  
**AM PEAK HOUR FACTOR:** 0.85  
**PM PEAK HOUR FACTOR:** 0.87

"AM EXISTING TRAFFIC"																	
	EBU	EBL	EBT	EBR	WBU	WBL	WBT	WBR	NBU	NBL	NBT	NBR	SBU	SBL	SBT	SBR	
AM Raw Turning Movements		19	72	3		3	9	18		2	132	13		7	74	7	
Peak Season Correction Factor	1.020	1.020	1.020	1.020	1.020	1.020	1.020	1.020	1.020	1.020	1.020	1.020	1.020	1.020	1.020	1.020	
Adjustment Factor	1.23	1.23	1.23	1.23	1.23	1.23	1.23	1.23	1.23	1.23	1.23	1.23	1.23	1.23	1.23	1.23	
<b>AM EXISTING CONDITIONS</b>		<b>24</b>	<b>90</b>	<b>4</b>		<b>4</b>	<b>11</b>	<b>23</b>		<b>3</b>	<b>166</b>	<b>16</b>		<b>9</b>	<b>93</b>	<b>9</b>	
"PM EXISTING TRAFFIC"																	
	EBU	EBL	EBT	EBR	WBU	WBL	WBT	WBR	NBU	NBL	NBT	NBR	SBU	SBL	SBT	SBR	
PM Raw Turning Movements		6	30	4		10	52	14		1	43	1		11	150	24	
Peak Season Correction Factor	1.020	1.020	1.020	1.020	1.020	1.020	1.020	1.020	1.020	1.020	1.020	1.020	1.020	1.020	1.020	1.020	
Adjustment Factor	1.23	1.23	1.23	1.23	1.23	1.23	1.23	1.23	1.23	1.23	1.23	1.23	1.23	1.23	1.23	1.23	
<b>PM EXISTING CONDITIONS</b>		<b>8</b>	<b>38</b>	<b>5</b>		<b>13</b>	<b>65</b>	<b>18</b>		<b>1</b>	<b>54</b>	<b>1</b>		<b>14</b>	<b>188</b>	<b>30</b>	
"AM BACKGROUND TRAFFIC"																	
PDL Blvd and Malaga Ave Signal Imp	EBU	EBL	EBT	EBR	WBU	WBL	WBT	WBR	NBU	NBL	NBT	NBR	SBU	SBL	SBT	SBR	
PDL Median		19	-19									19					
The Plaza Coral Gables											3				14		
<b>TOTAL "VESTED" TRAFFIC</b>		<b>19</b>	<b>-19</b>	<b>0</b>		<b>0</b>	<b>0</b>	<b>0</b>		<b>0</b>	<b>3</b>	<b>19</b>		<b>0</b>	<b>14</b>	<b>0</b>	
Years To Buildout	2	2	2	2	2	2	2	2	2	2	2	2	2	2	2	2	
Yearly Growth Rate	0.51%	0.51%	0.51%	0.51%	0.51%	0.51%	0.51%	0.51%	0.51%	0.51%	0.51%	0.51%	0.51%	0.51%	0.51%	0.51%	
<b>AM BACKGROUND TRAFFIC GROWTH</b>		<b>0</b>	<b>1</b>	<b>0</b>		<b>0</b>	<b>0</b>	<b>0</b>		<b>0</b>	<b>2</b>	<b>0</b>		<b>0</b>	<b>1</b>	<b>0</b>	
<b>AM NON-PROJECT TRAFFIC</b>		<b>43</b>	<b>72</b>	<b>4</b>		<b>4</b>	<b>11</b>	<b>23</b>		<b>3</b>	<b>171</b>	<b>35</b>		<b>9</b>	<b>108</b>	<b>9</b>	
"PM BACKGROUND TRAFFIC"																	
PDL Blvd and Malaga Ave Signal Imp	EBU	EBL	EBT	EBR	WBU	WBL	WBT	WBR	NBU	NBL	NBT	NBR	SBU	SBL	SBT	SBR	
PDL Median		8	-8									26					
The Plaza Coral Gables											15				8		
<b>TOTAL "VESTED" TRAFFIC</b>		<b>8</b>	<b>-8</b>	<b>0</b>		<b>0</b>	<b>0</b>	<b>0</b>		<b>0</b>	<b>15</b>	<b>26</b>		<b>0</b>	<b>8</b>	<b>0</b>	
Years To Buildout	2	2	2	2	2	2	2	2	2	2	2	2	2	2	2	2	
Yearly Growth Rate	0.51%	0.51%	0.51%	0.51%	0.51%	0.51%	0.51%	0.51%	0.51%	0.51%	0.51%	0.51%	0.51%	0.51%	0.51%	0.51%	
<b>PM BACKGROUND TRAFFIC GROWTH</b>		<b>0</b>	<b>0</b>	<b>0</b>		<b>0</b>	<b>1</b>	<b>0</b>		<b>0</b>	<b>1</b>	<b>0</b>		<b>0</b>	<b>2</b>	<b>0</b>	
<b>PM NON-PROJECT TRAFFIC</b>		<b>16</b>	<b>30</b>	<b>5</b>		<b>13</b>	<b>66</b>	<b>18</b>		<b>1</b>	<b>70</b>	<b>27</b>		<b>14</b>	<b>198</b>	<b>30</b>	
"AM PROJECT DISTRIBUTION"																	
LAND USE	TYPE	EBU	EBL	EBT	EBR	WBU	WBL	WBT	WBR	NBU	NBL	NBT	NBR	SBU	SBL	SBT	SBR
Pass-By Distribution	Entering																
	Exiting																
Valet Distribution	Entering												100.0%				
	Exiting																
Net New Distribution	Entering			52.0%									24.0%				
	Exiting							62.0%	24.0%								
"PM PROJECT DISTRIBUTION"																	
LAND USE	TYPE	EBU	EBL	EBT	EBR	WBU	WBL	WBT	WBR	NBU	NBL	NBT	NBR	SBU	SBL	SBT	SBR
Pass-By Distribution	Entering																
	Exiting																
Valet Distribution	Entering												100.0%				
	Exiting																
Net New Distribution	Entering			52.0%									24.0%				
	Exiting							62.0%	24.0%								
"AM PROJECT TRAFFIC"																	
LAND USE	TYPE	EBU	EBL	EBT	EBR	WBU	WBL	WBT	WBR	NBU	NBL	NBT	NBR	SBU	SBL	SBT	SBR
<b>AM TRAFFIC DIVERSIONS</b>																	
Project Trips	Pass - By																
	Valet												7				
	Net New			0				27	11				0				
<b>AM TOTAL PROJECT TRAFFIC</b>		<b>0</b>	<b>0</b>	<b>0</b>		<b>0</b>	<b>27</b>	<b>11</b>		<b>0</b>	<b>0</b>	<b>7</b>		<b>0</b>	<b>0</b>	<b>0</b>	
<b>AM TOTAL TRAFFIC</b>		<b>43</b>	<b>72</b>	<b>4</b>		<b>4</b>	<b>38</b>	<b>34</b>		<b>3</b>	<b>171</b>	<b>42</b>		<b>9</b>	<b>108</b>	<b>9</b>	
"PM PROJECT TRAFFIC"																	
LAND USE	TYPE	EBU	EBL	EBT	EBR	WBU	WBL	WBT	WBR	NBU	NBL	NBT	NBR	SBU	SBL	SBT	SBR
<b>PM TRAFFIC DIVERSIONS</b>																	
Project Trips	Pass - By																
	Valet												32				
	Net New			24				21	8				11				
<b>PM TOTAL PROJECT TRAFFIC</b>		<b>0</b>	<b>24</b>	<b>0</b>		<b>0</b>	<b>21</b>	<b>8</b>		<b>0</b>	<b>0</b>	<b>43</b>		<b>0</b>	<b>0</b>	<b>0</b>	
<b>PM TOTAL TRAFFIC</b>		<b>16</b>	<b>54</b>	<b>5</b>		<b>13</b>	<b>87</b>	<b>26</b>		<b>1</b>	<b>70</b>	<b>70</b>		<b>14</b>	<b>198</b>	<b>30</b>	

# TRAFFIC VOLUMES AT STUDY INTERSECTIONS

**INTERSECTION:** Malaga Avenue and SW 42nd Avenue  
**COUNT DATE:** October 14, 2020  
**AM PEAK HOUR FACTOR:** 0.92  
**PM PEAK HOUR FACTOR:** 0.98

"AM EXISTING TRAFFIC"																	
	EBU	EBL	EBT	EBR	WBU	WBL	WBT	WBR	NBU	NBL	NBT	NBR	SBU	SBL	SBT	SBR	
AM Raw Turning Movements		10	0	18		1	0	18		10	966	2		23	945	11	
Peak Season Correction Factor	1.020	1.020	1.020	1.020	1.020	1.020	1.020	1.020	1.020	1.020	1.020	1.020	1.020	1.020	1.020	1.020	
Adjustment Factor	1.23	1.23	1.23	1.23	1.23	1.23	1.23	1.23	1.23	1.23	1.23	1.23	1.23	1.23	1.23	1.23	
<b>AM EXISTING CONDITIONS</b>		13	0	23		1	0	23		13	1,212	3		29	1,186	14	
"PM EXISTING TRAFFIC"																	
	EBU	EBL	EBT	EBR	WBU	WBL	WBT	WBR	NBU	NBL	NBT	NBR	SBU	SBL	SBT	SBR	
PM Raw Turning Movements		9	0	6		1	0	40		17	789	2		8	1,025	16	
Peak Season Correction Factor	1.020	1.020	1.020	1.020	1.020	1.020	1.020	1.020	1.020	1.020	1.020	1.020	1.020	1.020	1.020	1.020	
Adjustment Factor	1.23	1.23	1.23	1.23	1.23	1.23	1.23	1.23	1.23	1.23	1.23	1.23	1.23	1.23	1.23	1.23	
<b>PM EXISTING CONDITIONS</b>		11	0	8		1	0	50		21	990	3		10	1,286	20	
"AM BACKGROUND TRAFFIC"																	
PDL Blvd and Malaga Ave Signal Imp	EBU	EBL	EBT	EBR	WBU	WBL	WBT	WBR	NBU	NBL	NBT	NBR	SBU	SBL	SBT	SBR	
PDL Median																	
The Plaza Coral Gables											20				5		
<b>TOTAL "VESTED" TRAFFIC</b>		0	0	0		0	0	0		0	20	0		0	5	0	
Years To Buildout	2	2	2	2	2	2	2	2	2	2	2	2	2	2	2	2	
Yearly Growth Rate	0.51%	0.51%	0.51%	0.51%	0.51%	0.51%	0.51%	0.51%	0.51%	0.51%	0.51%	0.51%	0.51%	0.51%	0.51%	0.51%	
<b>AM BACKGROUND TRAFFIC GROWTH</b>		0	0	0		0	0	0		0	12	0		0	12	0	
<b>AM NON-PROJECT TRAFFIC</b>		13	0	23		1	0	23		13	1,244	3		29	1,203	14	
"PM BACKGROUND TRAFFIC"																	
PDL Blvd and Malaga Ave Signal Imp	EBU	EBL	EBT	EBR	WBU	WBL	WBT	WBR	NBU	NBL	NBT	NBR	SBU	SBL	SBT	SBR	
PDL Median																	
The Plaza Coral Gables											13				23		
<b>TOTAL "VESTED" TRAFFIC</b>		0	0	0		0	0	0		0	13	0		0	23	0	
Years To Buildout	2	2	2	2	2	2	2	2	2	2	2	2	2	2	2	2	
Yearly Growth Rate	0.51%	0.51%	0.51%	0.51%	0.51%	0.51%	0.51%	0.51%	0.51%	0.51%	0.51%	0.51%	0.51%	0.51%	0.51%	0.51%	
<b>PM BACKGROUND TRAFFIC GROWTH</b>		0	0	0		0	0	1		0	10	0		0	13	0	
<b>PM NON-PROJECT TRAFFIC</b>		11	0	8		1	0	51		21	1,013	3		10	1,322	20	
"AM PROJECT DISTRIBUTION"																	
LAND USE	TYPE	EBU	EBL	EBT	EBR	WBU	WBL	WBT	WBR	NBU	NBL	NBT	NBR	SBU	SBL	SBT	SBR
Pass-By Distribution	Entering																
	Exiting																
Valet Distribution	Entering																
	Exiting																
Net New Distribution	Entering											22.0%					
	Exiting															32.0%	
"PM PROJECT DISTRIBUTION"																	
LAND USE	TYPE	EBU	EBL	EBT	EBR	WBU	WBL	WBT	WBR	NBU	NBL	NBT	NBR	SBU	SBL	SBT	SBR
Pass-By Distribution	Entering																
	Exiting																
Valet Distribution	Entering																
	Exiting																
Net New Distribution	Entering											22.0%					
	Exiting															32.0%	
"AM PROJECT TRAFFIC"																	
LAND USE	TYPE	EBU	EBL	EBT	EBR	WBU	WBL	WBT	WBR	NBU	NBL	NBT	NBR	SBU	SBL	SBT	SBR
<b>AM TRAFFIC DIVERSIONS</b>																	
Project Trips	Pass - By																
	Valet																
	Net New											0				14	
<b>AM TOTAL PROJECT TRAFFIC</b>		0	0	0		0	0	0		0	0	0		0	14	0	
<b>AM TOTAL TRAFFIC</b>		13	0	23		1	0	23		13	1,244	3		29	1,217	14	
"PM PROJECT TRAFFIC"																	
LAND USE	TYPE	EBU	EBL	EBT	EBR	WBU	WBL	WBT	WBR	NBU	NBL	NBT	NBR	SBU	SBL	SBT	SBR
<b>PM TRAFFIC DIVERSIONS</b>																	
Project Trips	Pass - By																
	Valet																
	Net New											10				11	
<b>PM TOTAL PROJECT TRAFFIC</b>		0	0	0		0	0	0		0	10	0		0	11	0	
<b>PM TOTAL TRAFFIC</b>		11	0	8		1	0	51		21	1,023	3		10	1,333	20	



# TRAFFIC VOLUMES AT STUDY INTERSECTIONS

**INTERSECTION:** Malaga Avenue and Salzedo Street  
**COUNT DATE:** October 14, 2020  
**AM PEAK HOUR FACTOR:** 0.86  
**PM PEAK HOUR FACTOR:** 0.92

"AM EXISTING TRAFFIC"	EBU	EBL	EBT	EBR	WBU	WBL	WBT	WBR	NBU	NBL	NBT	NBR	SBU	SBL	SBT	SBR
AM Raw Turning Movements		4	20	5		1	13	17		3	126	2		9	67	4
Peak Season Correction Factor	1.020	1.020	1.020	1.020	1.020	1.020	1.020	1.020	1.020	1.020	1.020	1.020	1.020	1.020	1.020	1.020
Adjustment Factor	1.23	1.23	1.23	1.23	1.23	1.23	1.23	1.23	1.23	1.23	1.23	1.23	1.23	1.23	1.23	1.23

AM EXISTING CONDITIONS	EBU	EBL	EBT	EBR	WBU	WBL	WBT	WBR	NBU	NBL	NBT	NBR	SBU	SBL	SBT	SBR
		5	25	6		1	16	21		4	158	3		11	84	5

"PM EXISTING TRAFFIC"	EBU	EBL	EBT	EBR	WBU	WBL	WBT	WBR	NBU	NBL	NBT	NBR	SBU	SBL	SBT	SBR
PM Raw Turning Movements		0	7	3		2	34	8		6	37	8		8	155	3
Peak Season Correction Factor	1.020	1.020	1.020	1.020	1.020	1.020	1.020	1.020	1.020	1.020	1.020	1.020	1.020	1.020	1.020	1.020
Adjustment Factor	1.23	1.23	1.23	1.23	1.23	1.23	1.23	1.23	1.23	1.23	1.23	1.23	1.23	1.23	1.23	1.23

PM EXISTING CONDITIONS	EBU	EBL	EBT	EBR	WBU	WBL	WBT	WBR	NBU	NBL	NBT	NBR	SBU	SBL	SBT	SBR
		0	9	4		3	43	10		8	46	10		10	194	4

"AM BACKGROUND TRAFFIC"	EBU	EBL	EBT	EBR	WBU	WBL	WBT	WBR	NBU	NBL	NBT	NBR	SBU	SBL	SBT	SBR
PDL Blvd and Malaga Ave Signal Imp																
PDL Median								19								
The Plaza Coral Gables								3						14		
TOTAL "VESTED" TRAFFIC		0	0	0		0	0	22		0	0	0		14	0	0

Years To Buildout	2	2	2	2	2	2	2	2	2	2	2	2	2	2	2	2
Yearly Growth Rate	0.51%	0.51%	0.51%	0.51%	0.51%	0.51%	0.51%	0.51%	0.51%	0.51%	0.51%	0.51%	0.51%	0.51%	0.51%	0.51%
AM BACKGROUND TRAFFIC GROWTH	0	0	0	0	0	0	0	0	0	2	0	0	0	1	0	0

AM NON-PROJECT TRAFFIC	EBU	EBL	EBT	EBR	WBU	WBL	WBT	WBR	NBU	NBL	NBT	NBR	SBU	SBL	SBT	SBR
		5	25	6		1	16	43		4	160	3		25	85	5

"PM BACKGROUND TRAFFIC"	EBU	EBL	EBT	EBR	WBU	WBL	WBT	WBR	NBU	NBL	NBT	NBR	SBU	SBL	SBT	SBR
PDL Blvd and Malaga Ave Signal Imp																
PDL Median								26								
The Plaza Coral Gables								15						8		
TOTAL "VESTED" TRAFFIC		0	0	0		0	0	41		0	0	0		8	0	0

Years To Buildout	2	2	2	2	2	2	2	2	2	2	2	2	2	2	2	2
Yearly Growth Rate	0.51%	0.51%	0.51%	0.51%	0.51%	0.51%	0.51%	0.51%	0.51%	0.51%	0.51%	0.51%	0.51%	0.51%	0.51%	0.51%
PM BACKGROUND TRAFFIC GROWTH	0	0	0	0	0	0	0	0	0	0	0	0	0	2	0	0

PM NON-PROJECT TRAFFIC	EBU	EBL	EBT	EBR	WBU	WBL	WBT	WBR	NBU	NBL	NBT	NBR	SBU	SBL	SBT	SBR
		0	9	4		3	43	51		8	46	10		18	196	4

"AM PROJECT DISTRIBUTION"		EBU	EBL	EBT	EBR	WBU	WBL	WBT	WBR	NBU	NBL	NBT	NBR	SBU	SBL	SBT	SBR
LAND USE	TYPE																
Pass-By	Entering																
Distribution	Exiting																
Valet	Entering							100.0%									
Distribution	Exiting																
Net New	Entering							14.0%			10.0%						
Distribution	Exiting																

"PM PROJECT DISTRIBUTION"		EBU	EBL	EBT	EBR	WBU	WBL	WBT	WBR	NBU	NBL	NBT	NBR	SBU	SBL	SBT	SBR
LAND USE	TYPE																
Pass-By	Entering																
Distribution	Exiting																
Valet	Entering							100.0%									
Distribution	Exiting																
Net New	Entering							14.0%			10.0%						
Distribution	Exiting																

"AM PROJECT TRAFFIC"		EBU	EBL	EBT	EBR	WBU	WBL	WBT	WBR	NBU	NBL	NBT	NBR	SBU	SBL	SBT	SBR
AM TRAFFIC DIVERSIONS																	
Project Trips	Pass - By																
	Valet							7									
	Net New							0			0						
AM TOTAL PROJECT TRAFFIC		0	0	0	0	0	0	7	0	0	0	0	0	0	0	0	0
AM TOTAL TRAFFIC		5	25	6	1	16	50	4	160	3	25	85	5				

"PM PROJECT TRAFFIC"		EBU	EBL	EBT	EBR	WBU	WBL	WBT	WBR	NBU	NBL	NBT	NBR	SBU	SBL	SBT	SBR
PM TRAFFIC DIVERSIONS																	
Project Trips	Pass - By																
	Valet							32									
	Net New							7			5						
PM TOTAL PROJECT TRAFFIC		0	0	0	0	0	0	39	0	5	0	0	0	0	0	0	0
PM TOTAL TRAFFIC		0	9	4	3	43	90	8	51	10	18	196	4				

# TRAFFIC VOLUMES AT STUDY INTERSECTIONS

**INTERSECTION:** University Drive and Salzedo Street  
**COUNT DATE:** October 14, 2020  
**AM PEAK HOUR FACTOR:** 0.91  
**PM PEAK HOUR FACTOR:** 0.94

"AM EXISTING TRAFFIC"																	
	EBU	EBL	EBT	EBR	WBU	WBL	WBT	WBR	NBU	NBL	NBT	NBR	SBU	SBL	SBT	SBR	
AM Raw Turning Movements		115	228	0			111	5		3	5	7		9	0	66	
Peak Season Correction Factor	1.020	1.020	1.020	1.020	1.020	1.020	1.020	1.020	1.020	1.020	1.020	1.020	1.020	1.020	1.020	1.020	
Adjustment Factor	1.23	1.23	1.23	1.23	1.23	1.23	1.23	1.23	1.23	1.23	1.23	1.23	1.23	1.23	1.23	1.23	
<b>AM EXISTING CONDITIONS</b>		<b>144</b>	<b>286</b>	<b>0</b>		<b>0</b>	<b>139</b>	<b>6</b>		<b>4</b>	<b>6</b>	<b>9</b>		<b>11</b>	<b>0</b>	<b>83</b>	
"PM EXISTING TRAFFIC"																	
	EBU	EBL	EBT	EBR	WBU	WBL	WBT	WBR	NBU	NBL	NBT	NBR	SBU	SBL	SBT	SBR	
PM Raw Turning Movements		29	76	0			284	5		2	5	4		9	0	149	
Peak Season Correction Factor	1.020	1.020	1.020	1.020	1.020	1.020	1.020	1.020	1.020	1.020	1.020	1.020	1.020	1.020	1.020	1.020	
Adjustment Factor	1.23	1.23	1.23	1.23	1.23	1.23	1.23	1.23	1.23	1.23	1.23	1.23	1.23	1.23	1.23	1.23	
<b>PM EXISTING CONDITIONS</b>		<b>36</b>	<b>95</b>	<b>0</b>		<b>0</b>	<b>356</b>	<b>6</b>		<b>3</b>	<b>6</b>	<b>5</b>		<b>11</b>	<b>0</b>	<b>187</b>	
"AM BACKGROUND TRAFFIC"																	
LAND USE	EBU	EBL	EBT	EBR	WBU	WBL	WBT	WBR	NBU	NBL	NBT	NBR	SBU	SBL	SBT	SBR	
PDL Blvd and Malaga Ave Signal Imp																	
PDL Median																	
The Plaza Coral Gables			68				16										
TOTAL "VESTED" TRAFFIC		0	68	0		0	16	0		0	0	0		0	0	0	
Years To Buildout	2	2	2	2	2	2	2	2	2	2	2	2	2	2	2	2	
Yearly Growth Rate	0.51%	0.51%	0.51%	0.51%	0.51%	0.51%	0.51%	0.51%	0.51%	0.51%	0.51%	0.51%	0.51%	0.51%	0.51%	0.51%	
AM BACKGROUND TRAFFIC GROWTH		1	3	0		0	1	0		0	0	0		0	0	1	
<b>AM NON-PROJECT TRAFFIC</b>		<b>145</b>	<b>357</b>	<b>0</b>		<b>0</b>	<b>156</b>	<b>6</b>		<b>4</b>	<b>6</b>	<b>9</b>		<b>11</b>	<b>0</b>	<b>84</b>	
"PM BACKGROUND TRAFFIC"																	
LAND USE	EBU	EBL	EBT	EBR	WBU	WBL	WBT	WBR	NBU	NBL	NBT	NBR	SBU	SBL	SBT	SBR	
PDL Blvd and Malaga Ave Signal Imp																	
PDL Median																	
The Plaza Coral Gables			42				76										
TOTAL "VESTED" TRAFFIC		0	42	0		0	76	0		0	0	0		0	0	0	
Years To Buildout	2	2	2	2	2	2	2	2	2	2	2	2	2	2	2	2	
Yearly Growth Rate	0.51%	0.51%	0.51%	0.51%	0.51%	0.51%	0.51%	0.51%	0.51%	0.51%	0.51%	0.51%	0.51%	0.51%	0.51%	0.51%	
PM BACKGROUND TRAFFIC GROWTH		0	1	0		0	4	0		0	0	0		0	0	2	
<b>PM NON-PROJECT TRAFFIC</b>		<b>36</b>	<b>138</b>	<b>0</b>		<b>0</b>	<b>436</b>	<b>6</b>		<b>3</b>	<b>6</b>	<b>5</b>		<b>11</b>	<b>0</b>	<b>189</b>	
"AM PROJECT DISTRIBUTION"																	
LAND USE	TYPE	EBU	EBL	EBT	EBR	WBU	WBL	WBT	WBR	NBU	NBL	NBT	NBR	SBU	SBL	SBT	SBR
Pass-By Distribution	Entering																
	Exiting																
Valet Distribution	Entering																
	Exiting																
Net New Distribution	Entering		10.0%														
	Exiting																
"PM PROJECT DISTRIBUTION"																	
LAND USE	TYPE	EBU	EBL	EBT	EBR	WBU	WBL	WBT	WBR	NBU	NBL	NBT	NBR	SBU	SBL	SBT	SBR
Pass-By Distribution	Entering																
	Exiting																
Valet Distribution	Entering																
	Exiting																
Net New Distribution	Entering		10.0%														
	Exiting																
"AM PROJECT TRAFFIC"																	
LAND USE	TYPE	EBU	EBL	EBT	EBR	WBU	WBL	WBT	WBR	NBU	NBL	NBT	NBR	SBU	SBL	SBT	SBR
AM TRAFFIC DIVERSIONS																	
Project Trips	Pass - By																
	Valet																
	Net New		0														
<b>AM TOTAL PROJECT TRAFFIC</b>		<b>0</b>	<b>0</b>	<b>0</b>	<b>0</b>	<b>0</b>	<b>0</b>	<b>0</b>	<b>0</b>	<b>0</b>	<b>0</b>	<b>0</b>	<b>0</b>	<b>0</b>	<b>0</b>	<b>0</b>	<b>0</b>
<b>AM TOTAL TRAFFIC</b>		<b>145</b>	<b>357</b>	<b>0</b>		<b>0</b>	<b>156</b>	<b>6</b>		<b>4</b>	<b>6</b>	<b>9</b>		<b>11</b>	<b>0</b>	<b>84</b>	
"PM PROJECT TRAFFIC"																	
LAND USE	TYPE	EBU	EBL	EBT	EBR	WBU	WBL	WBT	WBR	NBU	NBL	NBT	NBR	SBU	SBL	SBT	SBR
PM TRAFFIC DIVERSIONS																	
Project Trips	Pass - By																
	Valet																
	Net New		5														
<b>PM TOTAL PROJECT TRAFFIC</b>		<b>5</b>	<b>0</b>	<b>0</b>	<b>0</b>	<b>0</b>	<b>0</b>	<b>0</b>	<b>0</b>	<b>0</b>	<b>0</b>	<b>0</b>	<b>0</b>	<b>0</b>	<b>0</b>	<b>0</b>	<b>0</b>
<b>PM TOTAL TRAFFIC</b>		<b>41</b>	<b>138</b>	<b>0</b>		<b>0</b>	<b>436</b>	<b>6</b>		<b>3</b>	<b>6</b>	<b>5</b>		<b>11</b>	<b>0</b>	<b>189</b>	

# TRAFFIC VOLUMES AT STUDY INTERSECTIONS

**INTERSECTION:** University Drive and SW 42nd Avenue  
**COUNT DATE:** October 14, 2020  
**AM PEAK HOUR FACTOR:** 0.91  
**PM PEAK HOUR FACTOR:** 0.95

"AM EXISTING TRAFFIC"																	
	EB2R	EBL	EBT	EBR	WBL2	WBL	WBT	WBR	NBL2	NBL	NBT	NBR	SBL	SBT	SBR	SBR2	
AM Raw Turning Movements	15	214	247	14	52	92	11	10	10	4	750	66	30	831	105	6	
Peak Season Correction Factor	1.020	1.020	1.020	1.020	1.020	1.020	1.020	1.020	1.020	1.020	1.020	1.020	1.020	1.020	1.020	1.020	
Adjustment Factor	1.23	1.23	1.23	1.23	1.23	1.23	1.23	1.23	1.23	1.23	1.23	1.23	1.23	1.23	1.23	1.23	
<b>AM EXISTING CONDITIONS</b>	<b>19</b>	<b>268</b>	<b>310</b>	<b>18</b>	<b>65</b>	<b>115</b>	<b>14</b>	<b>13</b>	<b>13</b>	<b>5</b>	<b>941</b>	<b>83</b>	<b>38</b>	<b>1,043</b>	<b>132</b>	<b>10</b>	
"PM EXISTING TRAFFIC"																	
	EB2R	EBL	EBT	EBR	WBL2	WBL	WBT	WBR	NBL2	NBL	NBT	NBR	SBL	SBT	SBR	SBR2	
PM Raw Turning Movements	14	94	70	11	169	223	33	10	26	5	694	31	12	768	217	17	
Peak Season Correction Factor	1.020	1.020	1.020	1.020	1.020	1.020	1.020	1.020	1.020	1.020	1.020	1.020	1.020	1.020	1.020	1.020	
Adjustment Factor	1.23	1.23	1.23	1.23	1.23	1.23	1.23	1.23	1.23	1.23	1.23	1.23	1.23	1.23	1.23	1.23	
<b>PM EXISTING CONDITIONS</b>	<b>18</b>	<b>118</b>	<b>88</b>	<b>14</b>	<b>212</b>	<b>280</b>	<b>41</b>	<b>13</b>	<b>33</b>	<b>6</b>	<b>871</b>	<b>39</b>	<b>15</b>	<b>964</b>	<b>272</b>	<b>21</b>	
"AM BACKGROUND TRAFFIC"																	
PDL Blvd and Malaga Ave Signal Imp																	
PDL Median																	
The Plaza Coral Gables			34			8	8				20	34			5		
<b>TOTAL "VESTED" TRAFFIC</b>	<b>0</b>	<b>0</b>	<b>34</b>	<b>0</b>	<b>0</b>	<b>8</b>	<b>8</b>	<b>0</b>	<b>0</b>	<b>0</b>	<b>20</b>	<b>34</b>	<b>0</b>	<b>0</b>	<b>5</b>	<b>0</b>	
Years To Buildout	2	2	2	2	2	2	2	2	2	2	2	2	2	2	2	2	
Yearly Growth Rate	0.51%	0.51%	0.51%	0.51%	0.51%	0.51%	0.51%	0.51%	0.51%	0.51%	0.51%	0.51%	0.51%	0.51%	0.51%	0.51%	
<b>AM BACKGROUND TRAFFIC GROWTH</b>	<b>0</b>	<b>3</b>	<b>3</b>	<b>0</b>	<b>1</b>	<b>1</b>	<b>0</b>	<b>0</b>	<b>0</b>	<b>0</b>	<b>10</b>	<b>1</b>	<b>0</b>	<b>11</b>	<b>1</b>	<b>0</b>	
<b>AM NON-PROJECT TRAFFIC</b>	<b>19</b>	<b>271</b>	<b>347</b>	<b>18</b>	<b>66</b>	<b>124</b>	<b>22</b>	<b>13</b>	<b>13</b>	<b>5</b>	<b>971</b>	<b>118</b>	<b>38</b>	<b>1,054</b>	<b>138</b>	<b>10</b>	
"PM BACKGROUND TRAFFIC"																	
PDL Blvd and Malaga Ave Signal Imp																	
PDL Median																	
The Plaza Coral Gables			21			38	38				13	21			23		
<b>TOTAL "VESTED" TRAFFIC</b>	<b>0</b>	<b>0</b>	<b>21</b>	<b>0</b>	<b>0</b>	<b>38</b>	<b>38</b>	<b>0</b>	<b>0</b>	<b>0</b>	<b>13</b>	<b>21</b>	<b>0</b>	<b>0</b>	<b>23</b>	<b>0</b>	
Years To Buildout	2	2	2	2	2	2	2	2	2	2	2	2	2	2	2	2	
Yearly Growth Rate	0.51%	0.51%	0.51%	0.51%	0.51%	0.51%	0.51%	0.51%	0.51%	0.51%	0.51%	0.51%	0.51%	0.51%	0.51%	0.51%	
<b>PM BACKGROUND TRAFFIC GROWTH</b>	<b>0</b>	<b>1</b>	<b>1</b>	<b>0</b>	<b>2</b>	<b>3</b>	<b>0</b>	<b>0</b>	<b>0</b>	<b>0</b>	<b>9</b>	<b>0</b>	<b>0</b>	<b>10</b>	<b>3</b>	<b>0</b>	
<b>PM NON-PROJECT TRAFFIC</b>	<b>18</b>	<b>119</b>	<b>110</b>	<b>14</b>	<b>214</b>	<b>321</b>	<b>79</b>	<b>13</b>	<b>33</b>	<b>6</b>	<b>893</b>	<b>60</b>	<b>15</b>	<b>974</b>	<b>298</b>	<b>21</b>	
"AM PROJECT DISTRIBUTION"																	
LAND USE	TYPE	EB2R	EBL	EBT	EBR	WBL2	WBL	WBT	WBR	NBL2	NBL	NBT	NBR	SBL	SBT	SBR	SBR2
Pass-By Distribution	Entering																
	Exiting																
Valet Distribution	Entering																
	Exiting																
Net New Distribution	Entering		7.0%	2.0%								15.0%	8.0%				
	Exiting													23.0%	9.0%		
"PM PROJECT DISTRIBUTION"																	
LAND USE	TYPE	EB2R	EBL	EBT	EBR	WBL2	WBL	WBT	WBR	NBL2	NBL	NBT	NBR	SBL	SBT	SBR	SBR2
Pass-By Distribution	Entering																
	Exiting																
Valet Distribution	Entering																
	Exiting																
Net New Distribution	Entering		7.0%	2.0%								15.0%	8.0%				
	Exiting													23.0%	9.0%		
"AM PROJECT TRAFFIC"																	
LAND USE	TYPE	EB2R	EBL	EBT	EBR	WBL2	WBL	WBT	WBR	NBL2	NBL	NBT	NBR	SBL	SBT	SBR	SBR2
<b>AM TRAFFIC DIVERSIONS</b>																	
Project Trips	Pass - By																
	Valet																
	Net New		0	0								0	0		10	4	
<b>AM TOTAL PROJECT TRAFFIC</b>		<b>0</b>	<b>0</b>	<b>0</b>	<b>0</b>	<b>0</b>	<b>0</b>	<b>0</b>	<b>0</b>	<b>0</b>	<b>0</b>	<b>0</b>	<b>0</b>	<b>0</b>	<b>10</b>	<b>4</b>	<b>0</b>
<b>AM TOTAL TRAFFIC</b>		<b>19</b>	<b>271</b>	<b>347</b>	<b>18</b>	<b>66</b>	<b>124</b>	<b>22</b>	<b>13</b>	<b>13</b>	<b>5</b>	<b>971</b>	<b>118</b>	<b>38</b>	<b>1,064</b>	<b>142</b>	<b>10</b>
"PM PROJECT TRAFFIC"																	
LAND USE	TYPE	EB2R	EBL	EBT	EBR	WBL2	WBL	WBT	WBR	NBL2	NBL	NBT	NBR	SBL	SBT	SBR	SBR2
<b>PM TRAFFIC DIVERSIONS</b>																	
Project Trips	Pass - By																
	Valet																
	Net New		3	1								7	4		8	3	
<b>PM TOTAL PROJECT TRAFFIC</b>		<b>0</b>	<b>3</b>	<b>1</b>	<b>0</b>	<b>0</b>	<b>0</b>	<b>0</b>	<b>0</b>	<b>0</b>	<b>0</b>	<b>7</b>	<b>4</b>	<b>0</b>	<b>8</b>	<b>3</b>	<b>0</b>
<b>PM TOTAL TRAFFIC</b>		<b>18</b>	<b>122</b>	<b>111</b>	<b>14</b>	<b>214</b>	<b>321</b>	<b>79</b>	<b>13</b>	<b>33</b>	<b>6</b>	<b>900</b>	<b>64</b>	<b>15</b>	<b>982</b>	<b>301</b>	<b>21</b>

# Scenario 1/2 Trip Worksheets

Catalonia Avenue and Salzedo Street (E)	AM Peak Hour													
	Factors Applied		Southbound			Northbound			Westbound			Eastbound		
	Category	Value	Left	Thru	Right	Left	Thru	Right	Left	Thru	Right	Left	Thru	Right
	RAW TMC		8	75	8	3	133	14	4	10	19	20	73	4
	PHF	0.85	10	89	10	4	157	17	5	12	23	24	86	5
PCSF	1.23	13	110	13	5	194	21	7	15	29	30	106	7	
GF	1.02	14	113	14	6	198	22	8	16	30	31	109	8	
<b>Ponce Signal Impv</b>														
PDL Median	Trip Gen & Dist.										19		-19	
The Plaza CG			14			3								
Ponce Park Tower							0		27	11		0		
<b>Existing</b>		13	110	13	5	194	21	7	15	29	30	106	7	
<b>Future</b>		14	113	14	6	198	22	8	16	30	31	109	8	
<b>Future + Trips</b>		14	127	14	6	201	41	8	43	41	50	90	8	

Catalonia Avenue and Salzedo Street (E)	PM Peak Hour													
	Factors Applied		Southbound			Northbound			Westbound			Eastbound		
	Category	Value	Left	Thru	Right	Left	Thru	Right	Left	Thru	Right	Left	Thru	Right
	RAW TMC		12	151	25	2	44	2	11	53	15	7	31	5
	PHF	0.87	14	174	29	3	51	3	13	61	18	9	36	6
PCSF	1.23	18	215	36	4	63	4	16	76	23	12	45	8	
GF	1.02	19	220	37	5	65	5	17	78	24	13	46	9	
<b>Ponce Signal Impv</b>														
PDL Median	Trip Gen & Dist.										26		-8	
The Plaza CG			8			15								
Ponce Park Tower								11		21	8		24	
<b>Existing</b>		18	215	36	4	63	4	16	76	23	12	45	8	
<b>Future</b>		19	220	37	5	65	5	17	78	24	13	46	9	
<b>Future + Trips</b>		19	228	37	5	80	42	17	99	32	21	62	9	

Catalonia Avenue at LeJeune (E)	AM Peak Hour													
	Factors Applied		Southbound			Northbound			Westbound			Eastbound		
	Category	Value	Left	Thru	Right	Left	Thru	Right	Left	Thru	Right	Left	Thru	Right
	RAW TMC		78	956	3	17	970	16	3	0	18	11	0	21
	PHF	0.91	86	1051	4	19	1066	18	4	0	20	13	0	24
PCSF	1.23	106	1293	5	24	1312	23	5	0	25	16	0	30	
GF	1.02	109	1319	6	25	1339	24	6	0	26	17	0	31	
<b>Ponce Signal Impv</b>														
PDL Median	Trip Gen & Dist.													
The Plaza CG			5			20								
Ponce Park Tower			0				0	14		13				
<b>Existing</b>		106	1293	5	24	1312	23	5	0	25	16	0	30	
<b>Future</b>		109	1319	6	25	1339	24	6	0	26	17	0	31	
<b>Future + Trips</b>		109	1324	6	25	1359	24	20	0	39	17	0	31	

Catalonia Avenue at LeJeune (E)	PM Peak Hour													
	Factors Applied		Southbound			Northbound			Westbound			Eastbound		
	Category	Value	Left	Thru	Right	Left	Thru	Right	Left	Thru	Right	Left	Thru	Right
	RAW TMC		37	1030	11	29	807	5	20	0	60	5	0	5
	PHF	0.97	39	1062	12	30	832	6	21	0	62	6	0	6
PCSF	1.23	48	1307	15	37	1024	8	26	0	77	8	0	8	
GF	1.02	49	1334	16	38	1045	9	27	0	79	9	0	9	
<b>Ponce Signal Impv</b>														
PDL Median	Trip Gen & Dist.													
The Plaza CG			23			13								
Ponce Park Tower			14					10		11		10		
<b>Existing</b>		48	1307	15	37	1024	8	26	0	77	8	0	8	
<b>Future</b>		49	1334	16	38	1045	9	27	0	79	9	0	9	
<b>Future + Trips</b>		63	1357	16	38	1058	19	38	0	89	9	0	9	



# **Appendix D**

## Trip Generation Letter

June 16, 2021

Ms. Jessica A. Keller  
Assistant Public Works Director, City of Coral Gables  
2800 SW 72 Ave  
Miami, Florida 33155

**Re: Alexan Craft - Trip Generation Analysis, Coral Gables, Florida**

Dear Ms. Keller:

Kimley-Horn and Associates, Inc. has performed a trip generation analysis for the Alexan Craft redevelopment generally bounded by Salzedo Street to the east, Le Jeune Road to the west, Catalonia Avenue to the north, and Malaga Avenue to the south in Coral Gables, Florida. Currently, the site proposed for redevelopment contains 13 single-family homes. The proposed redevelopment consists of 283 multifamily residential units and an on-site parking garage. Access to the site is provided via one (1) ingress-only driveway along Catalonia Avenue and one (1) egress-only driveway along Malaga Avenue. A conceptual site plan is provided in Attachment A.

Trip generation calculations for the existing development and proposed redevelopment were performed using Institute of Transportation Engineer' (ITE) *Trip Generation Manual*, 10<sup>th</sup> Edition. ITE Land Use Code (LUC) 210 (Single-Family Detached Housing) was utilized for the existing development and LUC 221 (Multifamily [Mid-Rise]) was utilized for the proposed redevelopment. A multimodal (public transit, bicycle, and pedestrian) factor based on US Census *Means of Transportation to Work* data was reviewed for the census tracts in the vicinity of the redevelopment. The US Census data indicated that there is a 7.8 percent (7.8%) multimodal factor within the vicinity of the development. It is expected that a portion of residents and guests will choose to walk, bike, or use public transit to and from the proposed redevelopment. As shown in Table 1, the trip generation calculations indicate that the proposed redevelopment represents 1,272 net new daily trips, 75 net new A.M. peak hour trips, and 98 net new P.M. peak hour trips. Detailed trip generation calculations are provided in Attachment B.

Development Plan	Daily	A.M. Peak Hour	P.M. Peak Hour
Existing (13 Homes)	148	13	13
Proposed (283 Units)	1,420	88	111
<b>ΔTrips</b>	<b>+1,272</b>	<b>+75</b>	<b>+98</b>

Sincerely,

KIMLEY-HORN AND ASSOCIATES, INC.



Omar Kanaan, P.E.  
Attachments

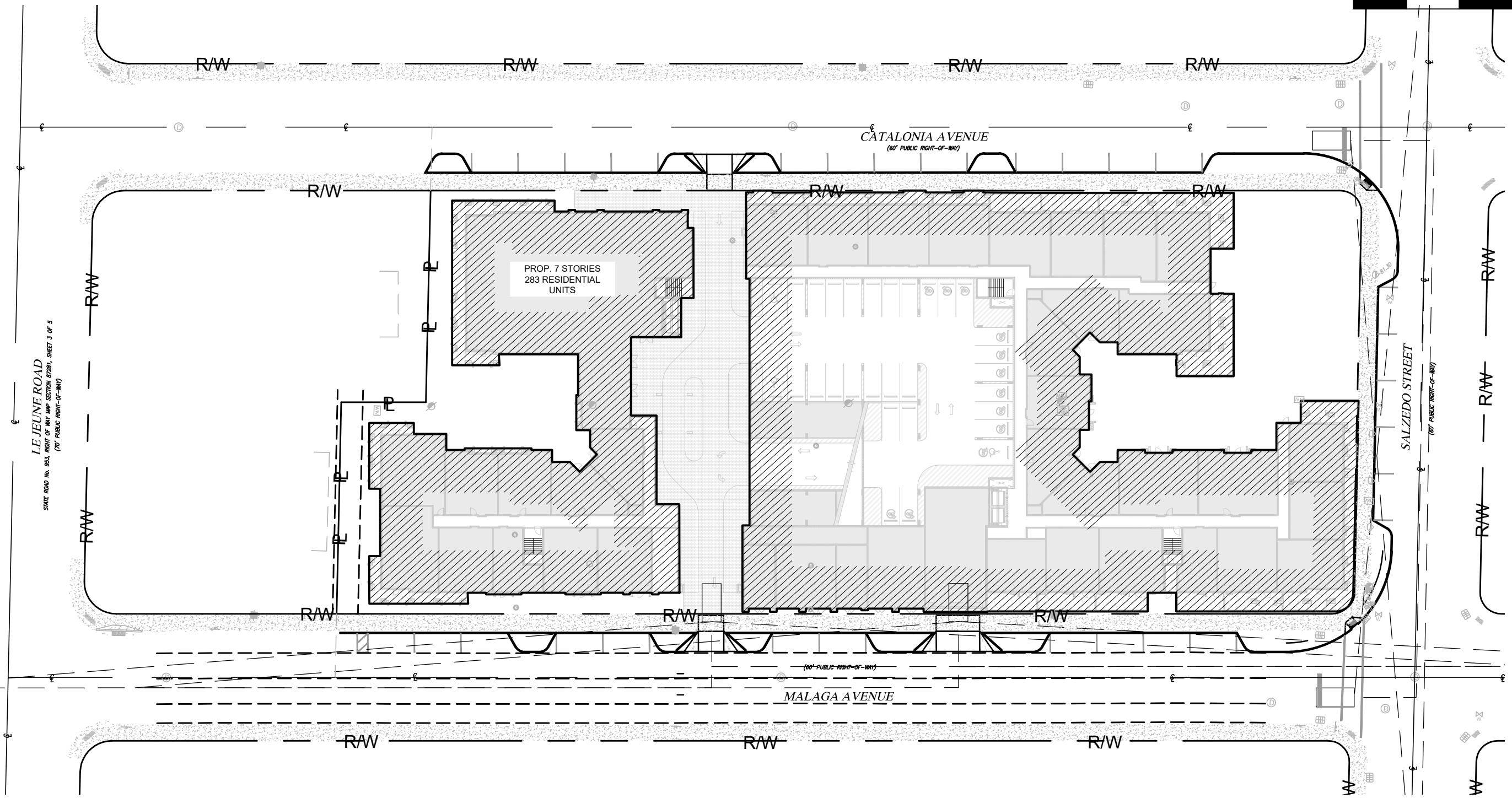
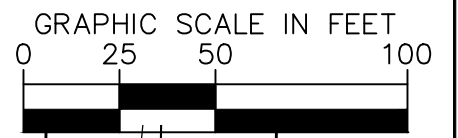


Florida Registration Number 81433  
Kimley-Horn and Associates, Inc.  
8201 Peters Road, Suite 2200  
Fort Lauderdale, FL 33324  
Registry 00000696



## **Attachment A**

Plotted By: Giraldo, Maggie Sheet Set: Kha Layout: Layout1 June 15, 2021 01:22:03pm K:\MIB\_Civil\043904007 - Alexan Crafts (Coral Gables)\CIVIL\CADD\Exhibits\2021.03.25\PROJECT SITE.dwg  
This document, together with the concepts and designs presented herein, is intended only for the specific purpose and client for which it was prepared. Reuse of and improper reliance on this document without written authorization and adaptation by Kimley-Horn and Associates, Inc. shall be without liability to Kimley-Horn and Associates, Inc.



© 2021 KIMLEY-HORN AND ASSOCIATES, INC.  
355 ALHAMBRA CIRCLE, SUITE 1400, CORAL GABLES, FL 33134  
PHONE: 305-673-2025  
WWW.KIMLEY-HORN.COM REGISTRY 696

ALEXAN CRAFTS

330 CATALONIA AVE

SHEET NUMBER

1

## **Attachment B**

# DAILY TRIP GENERATION COMPARISON

## EXISTING DAILY TRIP GENERATION

ITE TRIP GENERATION CHARACTERISTICS							DIRECTIONAL DISTRIBUTION		BASELINE TRIPS			MULTIMODAL REDUCTION		GROSS TRIPS			PASS-BY CAPTURE		NET NEW EXTERNAL TRIPS							
Land Use	Land Use Type	ITE Edition	ITE Code	Scale	ITE Units	Percent		In	Out	Total	Percent	MR Trips	In	Out	Total	Percent	PB Trips	In	Out	Total						
						In	Out																			
1 Single-Family Detached Housing	Residential	10	210	13	du	50%	50%	80	80	160	7.8%	12	74	74	148	0.0%	0	74	74	148						
2																										
3																										
4																										
5																										
6																										
7																										
8																										
9																										
10																										
11																										
12																										
13																										
14																										
15																										
ITE Land Use Code 210							Rate or Equation $LN(Y) = 0.92 * LN(X) + 2.71$					<b>Total:</b>		80	80	160	7.8%	12	74	74	148	0.0%	0	74	74	148

## PROPOSED DAILY TRIP GENERATION

ITE TRIP GENERATION CHARACTERISTICS							DIRECTIONAL DISTRIBUTION		BASELINE TRIPS			MULTIMODAL REDUCTION		GROSS TRIPS			PASS-BY CAPTURE		NET NEW EXTERNAL TRIPS							
Land Use	Land Use Type	ITE Edition	ITE Code	Scale	ITE Units	Percent		In	Out	Total	Percent	MR Trips	In	Out	Total	Percent	PB Trips	In	Out	Total						
						In	Out																			
1 Multifamily (Mid-Rise)	Residential	10	221	283	du	50%	50%	770	770	1,540	7.8%	120	710	710	1,420	0.0%	0	710	710	1,420						
2																										
3																										
4																										
5																										
6																										
7																										
8																										
9																										
10																										
11																										
12																										
13																										
14																										
15																										
ITE Land Use Code 221							Rate or Equation $Y = 5.45 * (X) - 1.75$					<b>Total:</b>		770	770	1,540	7.8%	120	710	710	1,420	0.0%	0	710	710	1,420

<b>NET NEW TRIPS</b>	<b>IN</b>	<b>OUT</b>	<b>TOTAL</b>
636	636	1,272	1,272

# AM PEAK HOUR TRIP GENERATION COMPARISON

## EXISTING WEEKDAY AM PEAK HOUR TRIP GENERATION

ITE TRIP GENERATION CHARACTERISTICS					DIRECTIONAL DISTRIBUTION		BASELINE TRIPS			MULTIMODAL REDUCTION		GROSS TRIPS			PASS-BY CAPTURE		NET NEW EXTERNAL TRIPS				
Land Use	ITE Edition	ITE Code	Scale	ITE Units	Percent		In	Out	Total	Percent	MR Trips	In	Out	Total	Percent	PB Trips	In	Out	Total		
					In	Out															
1 Single-Family Detached Housing	10	210	13	du	25%	75%	4	10	14	7.8%	1	4	9	13	0.0%	0	4	9	13		
2																					
3																					
4																					
5																					
6																					
7																					
8																					
9																					
10																					
11																					
12																					
13																					
14																					
15																					
ITE Land Use Code					Rate or Equation		<b>Total:</b>														
210					Y=0.71*(X)+4.8				4	10	14	7.8%	1	4	9	13	0.0%	0	4	9	13

## PROPOSED WEEKDAY AM PEAK HOUR TRIP GENERATION

ITE TRIP GENERATION CHARACTERISTICS					DIRECTIONAL DISTRIBUTION		BASELINE TRIPS			MULTIMODAL REDUCTION		GROSS TRIPS			PASS-BY CAPTURE		NET NEW EXTERNAL TRIPS				
Land Use	ITE Edition	ITE Code	Scale	ITE Units	Percent		In	Out	Total	Percent	MR Trips	In	Out	Total	Percent	PB Trips	In	Out	Total		
					In	Out															
1 Multifamily (Mid-Rise)	10	221	283	du	26%	74%	25	70	95	7.8%	7	23	65	88	0.0%	0	23	65	88		
2																					
3																					
4																					
5																					
6																					
7																					
8																					
9																					
10																					
11																					
12																					
13																					
14																					
15																					
ITE Land Use Code					Rate or Equation		<b>Total:</b>														
221					LN(Y) = 0.98*LN(X)+0.98				25	70	95	7.8%	7	23	65	88	0.0%	0	23	65	88

	IN	OUT	TOTAL
<b>NET NEW TRIPS</b>	<b>19</b>	<b>56</b>	<b>75</b>

# PM PEAK HOUR TRIP GENERATION COMPARISON

## EXISTING WEEKDAY PM PEAK HOUR TRIP GENERATION

	ITE TRIP GENERATION CHARACTERISTICS						DIRECTIONAL DISTRIBUTION		BASELINE TRIPS			MULTIMODAL REDUCTION		GROSS TRIPS			PASS-BY CAPTURE		NET NEW EXTERNAL TRIPS				
	Land Use	Land Use Type	ITE Edition	ITE Code	Scale	ITE Units	Percent		In	Out	Total	Percent	MR Trips	In	Out	Total	Percent	PB Trips	In	Out	Total		
							In	Out															
GROUP 1	1	Single-Family Detached Housing	Residential	10	210	13	du	63%	37%	9	5	14	7.8%	1	8	5	13	0.0%	0	8	5	13	
	2																						
	3																						
	4																						
	5																						
	6																						
	7																						
	8																						
	9																						
	10																						
	11																						
	12																						
	13																						
	14																						
	15																						
		ITE Land Use Code		Rate or Equation		Total:		9	5	14	7.8%	1	8	5	13	0.0%	0	8	5	13			
		210		LN(Y) = 0.96*LN(X)+0.2																			

## PROPOSED WEEKDAY PM PEAK HOUR TRIP GENERATION

	ITE TRIP GENERATION CHARACTERISTICS						DIRECTIONAL DISTRIBUTION		BASELINE TRIPS			MULTIMODAL REDUCTION		GROSS TRIPS			PASS-BY CAPTURE		NET NEW EXTERNAL TRIPS				
	Land Use	Land Use Type	ITE Edition	ITE Code	Scale	ITE Units	Percent		In	Out	Total	Percent	MR Trips	In	Out	Total	Percent	PB Trips	In	Out	Total		
							In	Out															
GROUP 2	1	Multifamily (Mid-Rise)	Residential	10	221	283	du	61%	39%	73	47	120	7.8%	9	67	44	111	0.0%	0	67	44	111	
	2																						
	3																						
	4																						
	5																						
	6																						
	7																						
	8																						
	9																						
	10																						
	11																						
	12																						
	13																						
	14																						
	15																						
		ITE Land Use Code		Rate or Equation		Total:		73	47	120	7.8%	9	67	44	111	0.0%	0	67	44	111			
		221		LN(Y) = 0.96*LN(X)+-0.63																			

	IN	OUT	TOTAL
<b>NET NEW TRIPS</b>	<b>59</b>	<b>39</b>	<b>98</b>

# MEANS OF TRANSPORTATION TO WORK

**Note:** This is a modified view of the original table produced by the U.S. Census Bureau. This download or printed version may have missing information from the original table.

		Census Tract 62.03, Miami-Dade County, Florida	
Label		Estimate	Margin of Error
▼ Total:		1,042	±181
▼ Car, truck, or van:		797	±155
Drove alone		696	±146
▼ Carpooled:		101	±90
In 2-person carpool		92	±88
In 3-person carpool		9	±16
In 4-person carpool		0	±13
In 5- or 6-person carpool		0	±13
In 7-or-more-person carpool		0	±13
▼ Public transportation (excluding taxicab):		47	±47
Bus or trolley bus		35	±44
Streetcar or trolley car (carro publico in Puerto Rico)		0	±13
Subway or elevated		12	±21
Railroad		0	±13
Ferryboat		0	±13
Taxicab		0	±13
Motorcycle		0	±13
Bicycle		6	±10
Walked		34	±27
Other means		40	±40
Worked at home		118	±66

$$(47+34)/1,042 = 7.8\%$$

## Table Notes

---

### MEANS OF TRANSPORTATION TO WORK

**Survey/Program:** American Community Survey

**Universe:** Workers 16 years and over

**Year:** 2018

**Estimates:** 5-Year

**Table ID:** B08301

Although the American Community Survey (ACS) produces population, demographic and housing unit estimates, it is the Census Bureau's Population Estimates Program that produces and disseminates the official estimates of the population for the nation, states, counties, cities, and towns and estimates of housing units for states and counties.

Source: U.S. Census Bureau, 2014-2018 American Community Survey 5-Year Estimates

Data are based on a sample and are subject to sampling variability. The degree of uncertainty for an estimate arising from sampling variability is represented through the use of a margin of error. The value shown here is the 90 percent margin of error. The margin of error can be interpreted roughly as providing a 90 percent probability that the interval defined by the estimate minus the margin of error and the estimate plus the margin of error (the lower and upper confidence bounds) contains the true value. In addition to sampling variability, the ACS estimates are subject to nonsampling error (for a discussion of nonsampling variability, see ACS Technical Documentation ). The effect of nonsampling error is not represented in these tables.

Workers include members of the Armed Forces and civilians who were at work last week.

While the 2014-2018 American Community Survey (ACS) data generally reflect the February 2013 Office of Management and Budget (OMB) definitions of metropolitan and micropolitan statistical areas; in certain instances the names, codes, and boundaries of the principal cities shown in ACS tables may differ from the OMB definitions due to differences in the effective dates of the geographic entities.

Estimates of urban and rural populations, housing units, and characteristics reflect boundaries of urban areas defined based on Census 2010 data. As a result, data for urban and rural areas from the ACS do not necessarily reflect the results of ongoing urbanization.

#### Explanation of Symbols:

An "\*\*" entry in the margin of error column indicates that either no sample observations or too few sample observations were available to compute a standard error and thus the margin of error. A statistical test is not appropriate.

An "-" entry in the estimate column indicates that either no sample observations or too few sample observations were available to compute an estimate, or a ratio of medians cannot be calculated because one or both of the median estimates falls in the lowest interval or upper interval of an open-ended distribution, or the margin of error associated with a median was larger than the median itself.

An "-" following a median estimate means the median falls in the lowest interval of an open-ended distribution.

An "+" following a median estimate means the median falls in the upper interval of an open-ended distribution.

An "\*\*\*\*" entry in the margin of error column indicates that the median falls in the lowest interval or upper interval of an open-ended distribution. A statistical test is not appropriate.

An "\*\*\*\*\*" entry in the margin of error column indicates that the estimate is controlled. A statistical test for sampling variability is not appropriate.

An "N" entry in the estimate and margin of error columns indicates that data for this geographic area cannot be displayed because the number of sample cases is too small.

An "(X)" means that the estimate is not applicable or not available.



Supporting documentation on code lists, subject definitions, data accuracy, and statistical testing can be found on the American Community Survey website in the Technical Documentation section.

Sample size and data quality measures (including coverage rates, allocation rates, and response rates) can be found on the American Community Survey website in the Methodology section.

# Appendix E

## Trip Distribution / TAZ Zones



MIAMI-DADE TRANSPORTATION PLANNING ORGANIZATION

2045LRTP

SUPPORTING DOCUMENTS

## DIRECTIONAL TRIP DISTRIBUTION REPORT

SEPTEMBER 2019

DIRECTIONAL TRIP DISTRIBUTION REPORT

Miami-Dade 2015 Base Year Direction Trip Distribution Summary											
TAZ of Origin		Trips / Percent	Cardinal Directions								Total Trips
County TAZ	Regional TAZ		NNE	ENE	ESE	SSE	SSW	WSW	WNW	NNW	
1067	3967	Trips	293	112	13	43	24	318	211	282	1,303
1067	3967	Percent	22.6	8.7	1.0	3.3	1.9	24.6	16.3	21.7	
1068	3968	Trips	838	180	27	10	86	735	610	619	3,197
1068	3968	Percent	27.0	5.8	0.9	0.3	2.8	23.7	19.7	19.9	
1069	3969	Trips	1,418	506	87	0	169	1,470	1,014	1,453	6,368
1069	3969	Percent	23.2	8.3	1.4	-	2.8	24.0	16.6	23.8	
1070	3970	Trips	755	369	125	0	434	1,050	751	1,188	4,831
1070	3970	Percent	16.2	7.9	2.7	-	9.3	22.5	16.1	25.4	
1071	3971	Trips	836	533	74	74	379	1,139	766	1,101	5,045
1071	3971	Percent	17.1	10.9	1.5	1.5	7.7	23.2	15.6	22.5	
1072	3972	Trips	1,007	551	48	152	474	1,136	769	999	5,317
1072	3972	Percent	19.6	10.7	0.9	3.0	9.2	22.1	15.0	19.5	
1073	3973	Trips	1,047	864	169	276	509	1,252	896	1,223	6,437
1073	3973	Percent	16.8	13.9	2.7	4.4	8.2	20.1	14.4	19.6	
1074	3974	Trips	1,285	910	171	422	1,027	1,041	1,081	1,623	7,885
1074	3974	Percent	17.0	12.0	2.3	5.6	13.6	13.8	14.3	21.5	
1075	3975	Trips	797	575	281	300	991	721	550	1,233	5,606
1075	3975	Percent	14.6	10.6	5.2	5.5	18.2	13.2	10.1	22.6	
1076	3976	Trips	1,465	1,450	649	663	1,030	1,173	1,023	1,722	9,406
1076	3976	Percent	16.0	15.8	7.1	7.2	11.2	12.8	11.2	18.8	
1077	3977	Trips	2,105	1,507	469	238	2,141	1,625	1,255	2,227	11,872
1077	3977	Percent	18.2	13.0	4.1	2.1	18.5	14.1	10.9	19.3	
1078	3978	Trips	482	595	129	191	357	289	234	440	2,798
1078	3978	Percent	17.7	21.9	4.7	7.0	13.1	10.7	8.6	16.2	
1079	3979	Trips	467	832	122	196	313	295	340	572	3,185
1079	3979	Percent	14.9	26.5	3.9	6.3	10.0	9.4	10.8	18.2	
1080	3980	Trips	810	794	386	220	491	549	501	609	4,418
1080	3980	Percent	18.6	18.2	8.8	5.0	11.3	12.6	11.5	14.0	
1081	3981	Trips	711	515	289	99	443	443	421	575	3,568
1081	3981	Percent	20.4	14.7	8.3	2.8	12.7	12.7	12.1	16.4	
1082	3982	Trips	392	156	105	135	238	191	149	331	1,707
1082	3982	Percent	23.1	9.2	6.2	8.0	14.0	11.3	8.8	19.5	
1083	3983	Trips	416	242	174	84	358	328	208	601	2,480
1083	3983	Percent	17.3	10.0	7.2	3.5	14.8	13.6	8.6	24.9	
1084	3984	Trips	1,013	640	316	81	495	1,195	741	1,235	5,864
1084	3984	Percent	17.7	11.2	5.5	1.4	8.7	20.9	13.0	21.6	
1085	3985	Trips	439	291	76	148	187	544	389	538	2,668
1085	3985	Percent	16.8	11.1	2.9	5.7	7.2	20.8	14.9	20.6	
1086	3986	Trips	3,909	1,348	523	-	1,164	3,849	3,181	4,298	19,630
1086	3986	Percent	21.4	7.4	2.9	-	6.4	21.1	17.4	23.5	
1087	3987	Trips	904	485	68	272	223	1,031	567	914	4,570
1087	3987	Percent	20.3	10.9	1.5	6.1	5.0	23.1	12.7	20.5	
1088	3988	Trips	1,992	452	92	-	493	1,724	1,985	2,109	9,370
1088	3988	Percent	22.5	5.1	1.0	-	5.6	19.5	22.4	23.8	
1089	3989	Trips	389	96	11	-	92	268	239	255	1,349
1089	3989	Percent	28.8	7.1	0.8	-	6.8	19.9	17.7	18.9	
1090	3990	Trips	329	37	4	8	50	247	156	330	1,186
1090	3990	Percent	28.3	3.2	0.4	0.7	4.3	21.3	13.5	28.4	
1091	3991	Trips	539	35	6	-	82	302	314	599	1,901
1091	3991	Percent	28.7	1.9	0.4	-	4.4	16.1	16.7	31.9	
1092	3992	Trips	748	361	9	8	162	375	286	803	2,793
1092	3992	Percent	27.2	13.1	0.3	0.3	5.9	13.6	10.4	29.2	

DIRECTIONAL TRIP DISTRIBUTION REPORT

Miami-Dade 2045 Cost Feasible Plan Direction Trip Distribution Summary											
TAZ of Origin		Trips / Percent	Cardinal Directions								Total Trips
County TAZ	Regional TAZ		NNE	ENE	ESE	SSE	SSW	WSW	WNW	NNW	
1067	3967	Trips	533	204	4	41	98	528	396	468	2,300
1067	3967	Percent	23.5	9.0	0.2	1.8	4.3	23.3	17.4	20.6	
1068	3968	Trips	1,109	222	31	38	178	1,001	824	863	4,350
1068	3968	Percent	26.0	5.2	0.7	0.9	4.2	23.5	19.3	20.2	
1069	3969	Trips	1,922	483	89	0	328	1,707	1,274	1,695	7,716
1069	3969	Percent	25.6	6.4	1.2	-	4.4	22.8	17.0	22.6	
1070	3970	Trips	1,520	697	103	0	641	1,214	980	1,453	6,788
1070	3970	Percent	23.0	10.6	1.6	-	9.7	18.4	14.8	22.0	
1071	3971	Trips	1,344	673	64	81	400	1,193	983	1,440	6,360
1071	3971	Percent	21.8	10.9	1.0	1.3	6.5	19.3	15.9	23.3	
1072	3972	Trips	1,405	799	105	117	530	1,564	1,094	1,336	7,229
1072	3972	Percent	20.2	11.5	1.5	1.7	7.6	22.5	15.7	19.2	
1073	3973	Trips	1,639	1,100	181	257	736	1,732	1,298	1,760	8,943
1073	3973	Percent	18.8	12.6	2.1	3.0	8.5	19.9	14.9	20.2	
1074	3974	Trips	1,797	1,161	116	366	1,345	1,281	1,247	1,955	9,543
1074	3974	Percent	19.4	12.5	1.3	4.0	14.5	13.8	13.5	21.1	
1075	3975	Trips	1,243	851	247	192	1,228	1,007	776	1,645	7,371
1075	3975	Percent	17.3	11.9	3.4	2.7	17.1	14.0	10.8	22.9	
1076	3976	Trips	1,898	2,076	623	753	1,612	1,422	1,280	2,160	12,044
1076	3976	Percent	16.1	17.6	5.3	6.4	13.6	12.0	10.8	18.3	
1077	3977	Trips	3,656	2,549	697	305	3,420	2,497	1,917	3,707	19,299
1077	3977	Percent	19.5	13.6	3.7	1.6	18.2	13.3	10.2	19.8	
1078	3978	Trips	751	721	107	233	449	360	399	722	3,827
1078	3978	Percent	20.1	19.3	2.9	6.2	12.0	9.6	10.7	19.3	
1079	3979	Trips	661	970	160	278	471	411	478	848	4,328
1079	3979	Percent	15.5	22.7	3.7	6.5	11.0	9.6	11.2	19.8	
1080	3980	Trips	1,190	1,171	442	242	734	797	675	855	6,251
1080	3980	Percent	19.5	19.2	7.2	4.0	12.0	13.1	11.1	14.0	
1081	3981	Trips	899	712	337	172	621	573	577	759	4,770
1081	3981	Percent	19.3	15.3	7.3	3.7	13.4	12.3	12.4	16.3	
1082	3982	Trips	561	331	153	110	324	320	289	577	2,688
1082	3982	Percent	21.0	12.4	5.7	4.1	12.2	12.0	10.9	21.7	
1083	3983	Trips	433	256	81	63	295	284	230	459	2,110
1083	3983	Percent	20.6	12.2	3.8	3.0	14.0	13.5	11.0	21.9	
1084	3984	Trips	1,256	617	243	39	638	1,332	751	1,593	6,678
1084	3984	Percent	19.4	9.5	3.8	0.6	9.9	20.6	11.6	24.6	
1085	3985	Trips	548	328	67	90	200	539	475	535	2,811
1085	3985	Percent	19.7	11.8	2.4	3.2	7.2	19.4	17.1	19.2	
1086	3986	Trips	4,671	1,691	575	-	1,561	4,133	3,773	5,005	22,670
1086	3986	Percent	21.8	7.9	2.7	-	7.3	19.3	17.6	23.4	
1087	3987	Trips	1,350	667	79	342	482	1,633	906	1,399	7,056
1087	3987	Percent	19.7	9.7	1.2	5.0	7.0	23.8	13.2	20.4	
1088	3988	Trips	3,114	751	134	-	788	2,312	2,491	2,905	13,130
1088	3988	Percent	24.9	6.0	1.1	-	6.3	18.5	19.9	23.3	
1089	3989	Trips	489	143	15	-	153	349	360	484	2,029
1089	3989	Percent	24.5	7.2	0.7	-	7.7	17.5	18.1	24.3	
1090	3990	Trips	492	58	12	2	69	277	195	481	1,630
1090	3990	Percent	31.0	3.7	0.8	0.1	4.3	17.5	12.3	30.3	
1091	3991	Trips	728	77	9	-	62	418	329	613	2,259
1091	3991	Percent	32.6	3.4	0.4	-	2.8	18.7	14.7	27.4	
1092	3992	Trips	949	375	9	2	238	549	338	869	3,360
1092	3992	Percent	28.5	11.3	0.3	0.1	7.2	16.5	10.2	26.1	

# **Appendix F**

## **Synchro Reports and Related Information**

# Signal Operating Plans / Time of Day (TOD) Schedule

Miami-Dade, FL



## TOD Schedule Report

2627 - LeJeune Rd &amp; University Dr

2070-1C-Econolite Type-Cobalt

3/30/2020, 2:03 PM

### Phase Data

Phase	Direction	Split	Timing Plan	Walk	Ped Clear	Min Green	Max Green	Vehicle Ext	MAX 2	MAX 3	Yellow	Red Clear
2	S - T	108	1	7	23	7	34	1	0	0	4.4	2.2
			2	7	23	7	40	1	40	0	4.4	2.2
			3	7	23	7	40	1	40	0	4.4	2.2
			4	0	0	0	0	0	0	0	0	0
3	E - L	18	1	0	0	5	5	2	17	0	3.7	2
			2	0	0	5	7	2	10	0	3.7	2
			3	0	0	5	7	2	10	0	3.7	2
			4	0	0	0	0	0	0	0	0	0
4	W - T	44	1	7	18	7	18	3.5	59	0	4	3
			2	7	18	7	17	2.5	21	0	4	3
			3	7	18	7	17	2.5	21	0	4	3
			4	0	0	0	0	0	0	0	0	0
6	N - T	108	1	7	23	7	34	1	0	0	4.4	2.2
			2	7	23	7	40	1	40	0	4.4	2.2
			3	7	23	7	40	1	40	0	4.4	2.2
			4	0	0	0	0	0	0	0	0	0
7	W - L	18	1	0	0	5	5	2	17	0	3.7	2
			2	0	0	5	7	2	10	0	3.7	2
			3	0	0	5	7	2	10	0	3.7	2
			4	0	0	0	0	0	0	0	0	0
8	E - T	44	1	7	18	7	18	3.5	59	0	4	3
			2	7	18	7	17	2.5	21	0	4	3
			3	7	18	7	17	2.5	21	0	4	3
			4	0	0	0	0	0	0	0	0	0



**Schedule - 1**

Day of Week

SUN	MON	TUE	WED	THU	FRI	SAT
-	X	X	X	X	X	-

**Day Plan - 1 -**

Time of Day	Action Plan	Cycle Length	Offset	Phs Spl 2	Phs Spl 3	Phs Spl 4	Phs Spl 6	Phs Spl 7	Phs Spl 8
00:00:00	14	75	68	41	12	22	41	12	22
00:30:00	62	-	-	-	-	-	-	-	-
05:00:00	14	75	68	41	12	22	41	12	22
06:00:00	5	190	57	106	20	64	106	20	64
10:30:00	6	170	39	108	18	44	108	18	44
15:30:00	7	190	24	110	25	55	110	25	55
16:00:00	37	190	24	110	25	55	110	25	55
18:30:00	7	190	24	110	25	55	110	25	55
20:00:00	12	80	84	46	12	22	46	12	22
21:00:00	14	75	68	41	12	22	41	12	22

**Schedule - 2**

Day of Week

SUN	MON	TUE	WED	THU	FRI	SAT
X	-	-	-	-	-	X

**Day Plan - 2 -**

Time of Day	Action Plan	Cycle Length	Offset	Phs Spl 2	Phs Spl 3	Phs Spl 4	Phs Spl 6	Phs Spl 7	Phs Spl 8
00:00:00	14	75	68	41	12	22	41	12	22
01:00:00	62	-	-	-	-	-	-	-	-
05:00:00	14	75	68	41	12	22	41	12	22
10:00:00	6	170	39	108	18	44	108	18	44
22:00:00	14	75	68	41	12	22	41	12	22

**Action Plan**

Name	Pattern	Enabled Logic Processor Statements
14	14	N/A
62	Free	N/A
14	14	N/A
5	5	N/A
6	6	N/A
7	7	N/A
37	7	N/A
7	7	N/A
12	12	N/A
14	14	N/A

Miami-Dade, FL



2627 - LeJeune Rd & University Dr - 2070-1C - Econolite Type - Cobalt

**Configuration Controller Sequence**

**Phase Ring Sequence and Assignment (MM) 1-1-1**

Hardware Alternate Sequence Enable: No

**Phase Ring Sequence**.....(Note: Sequences identical to the prior one are not printed)

	01	02	03	04	05	06	07	08	09	10	11	12	13	14	15	16
	B	B														

Sequence 1

Ring 1		2		3		4	.	.	.	.	.	.	.	.	.	.
Ring 2		6		7		8	.	.	.	.	.	.	.	.	.	.

**Phases In Use/Exclusive Ped (MM) 1-2**

Phase	1	2	3	4	5	6	7	8	9	10	11	12	13	14	15	16
Phases In Use		X	X	X		X	X	X								
Exclusive Ped																

**Phase Compatibility (MM)**

1-1-2

Phase	
n/a	Barrier Mode

**Phase and Overlap Descriptions**

Phase	1	2	3	4	5	6	7	8	9	10	11	12	13	14	15	16
Approach	N	S	E	W	N	N	W	E	N	N	N	N	N	N	N	N
Movement		T	L	T		T	L	T								
Associated PED		X		X		X		X								
Overlap	A	B	C	D	E	F	G	H	I	J	K	L	M	N	O	P
Approach	N	N	N	N	N	N	N	N	N	N	N	N	N	N	N	N
Movement																

**Administration (MM) 1-7-1**

Enable Controller/Cabinet No  
 Interlock CRC  
 CRC (16 bit) 1B18  
 Enable Automatic Backup to Datakey Yes

**Backup Prevent (MM) 1-1-3**

Phases	1	2	3	4	5	6	7	8	9	10	11	12	13	14	15	16
Timing	1	.	.	.	.	.	.	.	.	.	.	.	.	.	.	.
Phases	2	.	.	.	.	.	.	.	.	.	.	.	.	.	.	.
	3	.	.	.	.	.	.	.	.	.	.	.	.	.	.	.
	4	.	.	X	.	.	.	.	.	.	.	.	.	.	.	.
	5	.	.	.	.	.	.	.	.	.	.	.	.	.	.	.
	6	.	.	.	.	.	.	.	.	.	.	.	.	.	.	.
	7	.	.	.	.	.	.	.	.	.	.	.	.	.	.	.
	8	.	.	.	.	.	X	.	.	.	.	.	.	.	.	.
	9	.	.	.	.	.	.	.	.	.	.	.	.	.	.	.
	10	.	.	.	.	.	.	.	.	.	.	.	.	.	.	.
	11	.	.	.	.	.	.	.	.	.	.	.	.	.	.	.
	12	.	.	.	.	.	.	.	.	.	.	.	.	.	.	.
	13	.	.	.	.	.	.	.	.	.	.	.	.	.	.	.
	14	.	.	.	.	.	.	.	.	.	.	.	.	.	.	.
	15	.	.	.	.	.	.	.	.	.	.	.	.	.	.	.
	16	.	.	.	.	.	.	.	.	.	.	.	.	.	.	.

**Simultaneous Gap (MM) 1-1-4**

Phases	1	2	3	4	5	6	7	8	9	10	11	12	13	14	15	16
	1	.	.	.	X	X	.	.	.	.	.	.	.	.	.	.
	2	.	.	.	X	X	.	.	.	.	.	.	.	.	.	.
	3	.	.	.	.	.	X	X	.	.	.	.	.	.	.	.
	4	.	.	.	.	.	X	X	.	.	.	.	.	.	.	.
	5	X	X	.	.	.	.	.	.	.	.	.	.	.	.	.
Phase	6	X	X	.	.	.	.	.	.	.	.	.	.	.	.	.
Must	7	.	.	X	X	.	.	.	.	.	.	.	.	.	.	.
Gap	8	.	.	X	X	.	.	.	.	.	.	.	.	.	.	.
With	9	.	.	.	.	.	.	.	.	.	.	.	.	.	.	.
Phase	10	.	.	.	.	.	.	.	.	.	.	.	.	.	.	.
	11	.	.	.	.	.	.	.	.	.	.	.	.	.	.	.
	12	.	.	.	.	.	.	.	.	.	.	.	.	.	.	.
	13	.	.	.	.	.	.	.	.	.	.	.	.	.	.	.
	14	.	.	.	.	.	.	.	.	.	.	.	.	.	.	.
	15	.	.	.	.	.	.	.	.	.	.	.	.	.	.	.
	16	.	.	.	.	.	.	.	.	.	.	.	.	.	.	.
Disable		.	.	.	.	.	.	.	.	.	.	.	.	.	.	.

**Load Switch Assignments (MM) 1-3**

	Phase / Overlap	Type	Dimming				Power Up	Auto		Flash Together
			Red	Yellow	Green	Dark		Red	Yellow	
1	0	.				+	.			
2	2	V				+	Yel		X	X
3	3	V				+	Red	X		
4	4	V				+	Red	X		
5	0	.				+	.			
6	6	V				+	Yel		X	X
7	7	V				+	Red	X		
8	8	V				+	Red	X		
9	0	.				+	.			
10	0	.				+	.			
11	0	.				+	.			
12	0	.				+	.			
13	2	P				+	.			
14	4	P				+	.			
15	6	P				+	.			
16	8	P				+	.			

Miami-Dade, FL



2627 - LeJeune Rd & University Dr - 2070-1C - Econolite Type - Cobalt

**Controller Timing Plan (MM) 2-1  
Plan 1 - "Phase Bank 1"**

Phase	1	2	3	4	5	6	7	8	9	10	11	12	13	14	15	16
Direction	N	S-T	E-L	W-T	N	N-T	W-L	E-T	N	N	N	N	N	N	N	N
Min Green	0	7	5	7	0	7	5	7	0	0	0	0	0	0	0	0
Bk Min Green	0	0	0	0	0	0	0	0	0	0	0	0	0	0	0	0
CS Min Green	0	0	0	0	0	0	0	0	0	0	0	0	0	0	0	0
Delay Green	0	0	0	0	0	0	0	0	0	0	0	0	0	0	0	0
Walk	0	7	0	7	0	7	0	7	0	0	0	0	0	0	0	0
Walk2	0	0	0	0	0	0	0	0	0	0	0	0	0	0	0	0
Walk Max	0	0	0	0	0	0	0	0	0	0	0	0	0	0	0	0
Ped Clear	0	23	0	18	0	23	0	18	0	0	0	0	0	0	0	0
Ped Clear 2	0	0	0	0	0	0	0	0	0	0	0	0	0	0	0	0
Ped Clear Max	0	0	0	0	0	0	0	0	0	0	0	0	0	0	0	0
Ped CO	0	0	0	0	0	0	0	0	0	0	0	0	0	0	0	0
Vehicle Ext	0.0	1.0	2.0	3.5	0.0	1.0	2.0	3.5	0.0	0.0	0.0	0.0	0.0	0.0	0.0	0.0
Vehicle Ext 2	0.0	0.0	0.0	0.0	0.0	0.0	0.0	0.0	0.0	0.0	0.0	0.0	0.0	0.0	0.0	0.0
Max1	0	34	5	18	0	34	5	18	0	0	0	0	0	0	0	0
Max2	0	0	17	59	0	0	17	59	0	0	0	0	0	0	0	0
Max3	0	0	0	0	0	0	0	0	0	0	0	0	0	0	0	0
DYM Max	0	0	0	0	0	0	0	0	0	0	0	0	0	0	0	0
Dym Step	0.0	0.0	0.0	0.0	0.0	0.0	0.0	0.0	0.0	0.0	0.0	0.0	0.0	0.0	0.0	0.0
Yellow	0.0	4.4	3.7	4.0	0.0	4.4	3.7	4.0	0.0	0.0	0.0	0.0	0.0	0.0	0.0	0.0
Red Clear	0.0	2.2	2.0	3.0	0.0	2.2	2.0	3.0	0.0	0.0	0.0	0.0	0.0	0.0	0.0	0.0
Red Max	0.0	0.0	0.0	0.0	0.0	0.0	0.0	0.0	0.0	0.0	0.0	0.0	0.0	0.0	0.0	0.0
Red Revert	0.0	0.0	0.0	0.0	0.0	0.0	0.0	0.0	0.0	0.0	0.0	0.0	0.0	0.0	0.0	0.0
Act B4	0	0	0	0	0	0	0	0	0	0	0	0	0	0	0	0
Sec/Act	0.0	0.0	0.0	0.0	0.0	0.0	0.0	0.0	0.0	0.0	0.0	0.0	0.0	0.0	0.0	0.0
Max Int	0	0	0	0	0	0	0	0	0	0	0	0	0	0	0	0
Time B4	0	0	0	0	0	0	0	0	0	0	0	0	0	0	0	0
Cars Wt	0	0	0	0	0	0	0	0	0	0	0	0	0	0	0	0
STPTDuc	0.0	0.0	0.0	0.0	0.0	0.0	0.0	0.0	0.0	0.0	0.0	0.0	0.0	0.0	0.0	0.0
TTReduc	0	0	0	0	0	0	0	0	0	0	0	0	0	0	0	0
Min Gap	0.0	1.0	2.0	3.5	0.0	1.0	2.0	3.5	0.0	0.0	0.0	0.0	0.0	0.0	0.0	0.0

## Plan 2 - "Phase Bank 2"

Phase	1	2	3	4	5	6	7	8	9	10	11	12	13	14	15	16
Direction	N	S-T	E-L	W-T	N	N-T	W-L	E-T	N	N	N	N	N	N	N	N
Min Green	0	7	5	7	0	7	5	7	0	0	0	0	0	0	0	0
Bk Min Green	0	0	0	0	0	0	0	0	0	0	0	0	0	0	0	0
CS Min Green	0	0	0	0	0	0	0	0	0	0	0	0	0	0	0	0
Delay Green	0	0	0	0	0	0	0	0	0	0	0	0	0	0	0	0
Walk	0	7	0	7	0	7	0	7	0	0	0	0	0	0	0	0
Walk2	0	0	0	0	0	0	0	0	0	0	0	0	0	0	0	0
Walk Max	0	0	0	0	0	0	0	0	0	0	0	0	0	0	0	0
Ped Clear	0	23	0	18	0	23	0	18	0	0	0	0	0	0	0	0
Ped Clear 2	0	0	0	0	0	0	0	0	0	0	0	0	0	0	0	0
Ped Clear Max	0	0	0	0	0	0	0	0	0	0	0	0	0	0	0	0
Ped CO	0	0	0	0	0	0	0	0	0	0	0	0	0	0	0	0
Vehicle Ext	0.0	1.0	2.0	2.5	0.0	1.0	2.0	2.5	0.0	0.0	0.0	0.0	0.0	0.0	0.0	0.0
Vehicle Ext 2	0.0	0.0	0.0	0.0	0.0	0.0	0.0	0.0	0.0	0.0	0.0	0.0	0.0	0.0	0.0	0.0
Max1	0	40	7	17	0	40	7	17	0	0	0	0	0	0	0	0
Max2	0	40	10	21	0	40	10	21	0	0	0	0	0	0	0	0
Max3	0	0	0	0	0	0	0	0	0	0	0	0	0	0	0	0
DYM Max	0	0	0	0	0	0	0	0	0	0	0	0	0	0	0	0
Dym Step	0.0	0.0	0.0	0.0	0.0	0.0	0.0	0.0	0.0	0.0	0.0	0.0	0.0	0.0	0.0	0.0
Yellow	0.0	4.4	3.7	4.0	0.0	4.4	3.7	4.0	0.0	0.0	0.0	0.0	0.0	0.0	0.0	0.0
Red Clear	0.0	2.2	2.0	3.0	0.0	2.2	2.0	3.0	0.0	0.0	0.0	0.0	0.0	0.0	0.0	0.0
Red Max	0.0	0.0	0.0	0.0	0.0	0.0	0.0	0.0	0.0	0.0	0.0	0.0	0.0	0.0	0.0	0.0
Red Revert	0.0	0.0	0.0	0.0	0.0	0.0	0.0	0.0	0.0	0.0	0.0	0.0	0.0	0.0	0.0	0.0
Act B4	0	0	0	0	0	0	0	0	0	0	0	0	0	0	0	0
Sec/Act	0.0	0.0	0.0	0.0	0.0	0.0	0.0	0.0	0.0	0.0	0.0	0.0	0.0	0.0	0.0	0.0
Max Int	0	0	0	0	0	0	0	0	0	0	0	0	0	0	0	0
Time B4	0	0	0	0	0	0	0	0	0	0	0	0	0	0	0	0
Cars Wt	0	0	0	0	0	0	0	0	0	0	0	0	0	0	0	0
STPTDuc	0.0	0.0	0.0	0.0	0.0	0.0	0.0	0.0	0.0	0.0	0.0	0.0	0.0	0.0	0.0	0.0
TTReduc	0	0	0	0	0	0	0	0	0	0	0	0	0	0	0	0
Min Gap	0.0	1.0	2.0	2.5	0.0	1.0	2.0	2.5	0.0	0.0	0.0	0.0	0.0	0.0	0.0	0.0

## Plan 3 - "Phase Bank 3"

Phase	1	2	3	4	5	6	7	8	9	10	11	12	13	14	15	16
Direction	N	S-T	E-L	W-T	N	N-T	W-L	E-T	N	N	N	N	N	N	N	N
Min Green	0	7	5	7	0	7	5	7	0	0	0	0	0	0	0	0
Bk Min Green	0	0	0	0	0	0	0	0	0	0	0	0	0	0	0	0
CS Min Green	0	0	0	0	0	0	0	0	0	0	0	0	0	0	0	0
Delay Green	0	0	0	0	0	0	0	0	0	0	0	0	0	0	0	0
Walk	0	7	0	7	0	7	0	7	0	0	0	0	0	0	0	0
Walk2	0	0	0	0	0	0	0	0	0	0	0	0	0	0	0	0
Walk Max	0	0	0	0	0	0	0	0	0	0	0	0	0	0	0	0
Ped Clear	0	23	0	18	0	23	0	18	0	0	0	0	0	0	0	0
Ped Clear 2	0	0	0	0	0	0	0	0	0	0	0	0	0	0	0	0
Ped Clear Max	0	0	0	0	0	0	0	0	0	0	0	0	0	0	0	0
Ped CO	0	0	0	0	0	0	0	0	0	0	0	0	0	0	0	0
Vehicle Ext	0.0	1.0	2.0	2.5	0.0	1.0	2.0	2.5	0.0	0.0	0.0	0.0	0.0	0.0	0.0	0.0
Vehicle Ext 2	0.0	0.0	0.0	0.0	0.0	0.0	0.0	0.0	0.0	0.0	0.0	0.0	0.0	0.0	0.0	0.0
Max1	0	40	7	17	0	40	7	17	0	0	0	0	0	0	0	0
Max2	0	40	10	21	0	40	10	21	0	0	0	0	0	0	0	0
Max3	0	0	0	0	0	0	0	0	0	0	0	0	0	0	0	0
DYM Max	0	0	0	0	0	0	0	0	0	0	0	0	0	0	0	0
Dym Step	0.0	0.0	0.0	0.0	0.0	0.0	0.0	0.0	0.0	0.0	0.0	0.0	0.0	0.0	0.0	0.0
Yellow	0.0	4.4	3.7	4.0	0.0	4.4	3.7	4.0	0.0	0.0	0.0	0.0	0.0	0.0	0.0	0.0
Red Clear	0.0	2.2	2.0	3.0	0.0	2.2	2.0	3.0	0.0	0.0	0.0	0.0	0.0	0.0	0.0	0.0
Red Max	0.0	0.0	0.0	0.0	0.0	0.0	0.0	0.0	0.0	0.0	0.0	0.0	0.0	0.0	0.0	0.0
Red Revert	0.0	0.0	0.0	0.0	0.0	0.0	0.0	0.0	0.0	0.0	0.0	0.0	0.0	0.0	0.0	0.0
Act B4	0	0	0	0	0	0	0	0	0	0	0	0	0	0	0	0
Sec/Act	0.0	0.0	0.0	0.0	0.0	0.0	0.0	0.0	0.0	0.0	0.0	0.0	0.0	0.0	0.0	0.0
Max Int	0	0	0	0	0	0	0	0	0	0	0	0	0	0	0	0
Time B4	0	0	0	0	0	0	0	0	0	0	0	0	0	0	0	0
Cars Wt	0	0	0	0	0	0	0	0	0	0	0	0	0	0	0	0
STPTDuc	0.0	0.0	0.0	0.0	0.0	0.0	0.0	0.0	0.0	0.0	0.0	0.0	0.0	0.0	0.0	0.0
TTReduc	0	0	0	0	0	0	0	0	0	0	0	0	0	0	0	0
Min Gap	0.0	1.0	2.0	2.5	0.0	1.0	2.0	2.5	0.0	0.0	0.0	0.0	0.0	0.0	0.0	0.0

## Plan 4 - "Phase Bank 4"

Phase	1	2	3	4	5	6	7	8	9	10	11	12	13	14	15	16
Direction	N	S-T	E-L	W-T	N	N-T	W-L	E-T	N	N	N	N	N	N	N	N
Min Green	0	0	0	0	0	0	0	0	0	0	0	0	0	0	0	0
Bk Min Green	0	0	0	0	0	0	0	0	0	0	0	0	0	0	0	0
CS Min Green	0	0	0	0	0	0	0	0	0	0	0	0	0	0	0	0
Delay Green	0	0	0	0	0	0	0	0	0	0	0	0	0	0	0	0
Walk	0	0	0	0	0	0	0	0	0	0	0	0	0	0	0	0
Walk2	0	0	0	0	0	0	0	0	0	0	0	0	0	0	0	0
Walk Max	0	0	0	0	0	0	0	0	0	0	0	0	0	0	0	0
Ped Clear	0	0	0	0	0	0	0	0	0	0	0	0	0	0	0	0
Ped Clear 2	0	0	0	0	0	0	0	0	0	0	0	0	0	0	0	0
Ped Clear Max	0	0	0	0	0	0	0	0	0	0	0	0	0	0	0	0
Ped CO	0	0	0	0	0	0	0	0	0	0	0	0	0	0	0	0
Vehicle Ext	0.0	0.0	0.0	0.0	0.0	0.0	0.0	0.0	0.0	0.0	0.0	0.0	0.0	0.0	0.0	0.0
Vehicle Ext 2	0.0	0.0	0.0	0.0	0.0	0.0	0.0	0.0	0.0	0.0	0.0	0.0	0.0	0.0	0.0	0.0
Max1	0	0	0	0	0	0	0	0	0	0	0	0	0	0	0	0
Max2	0	0	0	0	0	0	0	0	0	0	0	0	0	0	0	0
Max3	0	0	0	0	0	0	0	0	0	0	0	0	0	0	0	0
DYM Max	0	0	0	0	0	0	0	0	0	0	0	0	0	0	0	0
Dym Step	0.0	0.0	0.0	0.0	0.0	0.0	0.0	0.0	0.0	0.0	0.0	0.0	0.0	0.0	0.0	0.0
Yellow	0.0	0.0	0.0	0.0	0.0	0.0	0.0	0.0	0.0	0.0	0.0	0.0	0.0	0.0	0.0	0.0
Red Clear	0.0	0.0	0.0	0.0	0.0	0.0	0.0	0.0	0.0	0.0	0.0	0.0	0.0	0.0	0.0	0.0
Red Max	0.0	0.0	0.0	0.0	0.0	0.0	0.0	0.0	0.0	0.0	0.0	0.0	0.0	0.0	0.0	0.0
Red Revert	0.0	0.0	0.0	0.0	0.0	0.0	0.0	0.0	0.0	0.0	0.0	0.0	0.0	0.0	0.0	0.0
Act B4	0	0	0	0	0	0	0	0	0	0	0	0	0	0	0	0
Sec/Act	0.0	0.0	0.0	0.0	0.0	0.0	0.0	0.0	0.0	0.0	0.0	0.0	0.0	0.0	0.0	0.0
Max Int	0	0	0	0	0	0	0	0	0	0	0	0	0	0	0	0
Time B4	0	0	0	0	0	0	0	0	0	0	0	0	0	0	0	0
Cars Wt	0	0	0	0	0	0	0	0	0	0	0	0	0	0	0	0
STPTDuc	0.0	0.0	0.0	0.0	0.0	0.0	0.0	0.0	0.0	0.0	0.0	0.0	0.0	0.0	0.0	0.0
TTReduc	0	0	0	0	0	0	0	0	0	0	0	0	0	0	0	0
Min Gap	0.0	0.0	0.0	0.0	0.0	0.0	0.0	0.0	0.0	0.0	0.0	0.0	0.0	0.0	0.0	0.0

Miami-Dade, FL



2627 - LeJeune Rd & University Dr - 2070-1C - Econolite Type - Cobalt

**Controller Overlaps**

**Vehicle Overlaps (MM) 2-2**

Overlap	Type	Lag Green	Yellow	Red	Adv. Green
---------	------	-----------	--------	-----	------------

**Phases**

Overlap	Phase	Included	Protect	Ped Protect	Not Overlap	Modifier	Lag X Phases	Lag 2 Phases	Flash Green
---------	-------	----------	---------	-------------	-------------	----------	--------------	--------------	-------------

**PPLT FYA**

Overlap	Protected Phase (Left Turn)	Permissive Phase (Opposing Thru)	Flashing Arrow Output	Flashing Arrow Output CH	Delay Start of FYA	Delay Start of Clearance	Action Plan SF Bit Disable	Ped Protected Enable
---------	-----------------------------	----------------------------------	-----------------------	--------------------------	--------------------	--------------------------	----------------------------	----------------------

**Guaranteed Minimum Time Data (MM) 2-4**

Phase	Min Green	Walk	Ped Clear	Yellow	Red Clear	Overlap Green
A01	5	4	7	3.0	2.0	5
B02	5	4	7	3.0	2.0	5
C03	5	4	7	3.0	2.0	5
D04	5	4	7	3.0	2.0	5
E05	5	4	7	3.0	2.0	5
F06	5	4	7	3.0	2.0	5
G07	5	4	7	3.0	2.0	5
H08	5	4	7	3.0	2.0	5
I09	5	4	7	3.0	2.0	5
J10	5	4	7	3.0	2.0	5
K11	5	4	7	3.0	2.0	5
L12	5	4	7	3.0	2.0	5
M13	5	4	7	3.0	2.0	5
N14	5	4	7	3.0	2.0	5
O15	5	4	7	3.0	2.0	5
P16	5	4	7	3.0	2.0	5



Miami-Dade, FL



2627 - LeJeune Rd & University Dr - 2070-1C - Econolite Type - Cobalt

**Controller Pedestrian Overlaps**

**Vehicle / Pedestrian Overlaps (MM) 2-3**

Included	Pedestrian Overlaps
----------	---------------------

Miami-Dade, FL



2627 - LeJeune Rd & University Dr - 2070-1C - Econolite Type - Cobalt

**Controller Options**

**Controller Options (MM) 2-6-1**

Phase	1	2	3	4	5	6	7	8	9	10	11	12	13	14	15	16
Flashing Grn Ph	.	.	.	.	.	.	.	.	.	.	.	.	.	.	.	.
Guar Passage																
Non-Act I																
Non-Act II																
Dual Entry				X				X								
Cond Service																
Cond Reservice																
Ped Re-Service																
Rest In Walk																
Flashing Walk																
Ped Clr-Yel				X				X								
Ped Clr-Red																
IGRN + Veh Ext																

Ped Clear Protect: Off    Unit Red Revert: 5.0    MUTCD 3 Seconds Don't Walk: No

**Pre-Timed Mode (MM) 2-7**

Enable Pre-Timed Mode: Free Input Disables Pre-Timed: No

Phase	1	2	3	4	5	6	7	8	9	10	11	12	13	14	15	16
Pre-Timed																

**Phase Recall Options (MM) 2-8**

**Plan # 1**

	1	2	3	4	5	6	7	8	9	10	11	12	13	14	15	16
Lock Detector																
Vehicle Recall																
Ped Recall		X				X										
Max Recall																
Soft Recall																
No Rest																
AI Calc																

**Plan # 2**

	1	2	3	4	5	6	7	8	9	10	11	12	13	14	15	16
Lock Detector																
Vehicle Recall																
Ped Recall		X				X										
Max Recall		X				X										
Soft Recall																
No Rest																
AI Calc																

**Plan # 3**

	1	2	3	4	5	6	7	8	9	10	11	12	13	14	15	16
Lock Detector																
Vehicle Recall																
Ped Recall		X				X										
Max Recall		X				X										
Soft Recall																
No Rest																
AI Calc																

**Plan # 4**

	1	2	3	4	5	6	7	8	9	10	11	12	13	14	15	16
Lock Detector																
Vehicle Recall																
Ped Recall																

Max Recall																			
Soft Recall																			
No Rest																			
Al Calc																			

Miami-Dade, FL



2627 - LeJeune Rd & University Dr - 2070-1C - Econolite Type - Cobalt

**Coordination Options**

**Options (MM) 3-1**

Manual Pattern	Auto	ECPI Coord	Yes
System Source	SYS	System Format	PTN
Splits In	Seconds	Offsets In	Seconds
Transition	Smooth	Max Select	MAXINH
Dwell / Add Time	0		
Delay Coord Wk-LZ	No	Force Off	Fixed
Offset Reference	Lag	Use Ped Time	Yes
Ped Recall	No	Ped Reservice	Yes
Local Zero	Yes	FO Added Ini	No
Override		Green	No
Re-sync Count	0	Multisync	No

**Auto Perm Minimum Green (Seconds) (MM) 3-4**

Phase	1	2	3	4	5	6	7	8	9	10	11	12	13	14	15	16
Minimum Green	0	0	0	0	0	0	0	0	0	0	0	0	0	0	0	0

**Split Demand (MM) 3-5**

Phase	1	2	3	4	5	6	7	8	9	10	11	12	13	14	15	16
Demand 1																
Demand 2																

Demand	1	2
Detector	0	0
Call Time (Sec)	0	0
Cycle Count	0	0

Miami-Dade, FL



2627 - LeJeune Rd & University Dr - 2070-1C - Econolite Type - Cobalt

**Coordination Pattern Data**  
**Coordinator Pattern Data (MM) 3-2**

**Coordinator Pattern # 3**

Split Pattern	3	TS2 (Pat-Off)	0-3	Splits In	Seconds
Cycle	90	Std (COS)	25	Offsets In	Seconds
Offset Value	54s	Dwell/Add Time	0		
Actuated Coord No		Timing Plan	0		
Actuated Walk Rest	No	Sequence	0		
Phase Reservice	No	Action Plan	0		
Max Select	None	Force Off	None		

**Split Preference Phases**

Phase	1	2	3	4	5	6	7	8	9	10	11	12	13	14	15	16
Description	N	S-T	E-L	W-T	N	N-T	W-L	E-T	N	N	N	N	N	N	N	N
Splits (Split Pat 3)	0	51	15	24	0	51	15	24	0	0	0	0	0	0	0	0
Pref 1	0	0	0	0	0	0	0	0	0	0	0	0	0	0	0	0
Pref 2	0	0	0	0	0	0	0	0	0	0	0	0	0	0	0	0

Ring	1	2	3	4
Ring Split Ext	0	0	0	0
Ring Displacement	-	0	0	0
Split Sum	90s	90s	0s	0s

Misc. Data  
 Veh Perm 1 0 Veh Perm 2 0 Veh Perm 2 Disp 0  
 Split Demand 0 Split Demand 0 Crossing Arterial 0  
 Pat 1 Pat 2 Pat

**Split Pattern**

Phase	1	2	3	4	5	6	7	8	9	10	11	12	13	14	15	16
Coord Phase		X				X										
Vehicle Recall																
Pedestrian Recall																
Recall to Max. Time																
Omit Phase									X	X	X	X	X	X	X	X
Special Function Outputs																

**Coordinator Pattern # 4**

Split Pattern 4 TS2 (Pat-Off) 1-1 Splits In Seconds  
 Cycle 70 Std (COS) 33 Offsets In Seconds  
 Offset Value 45s Dwell/Add Time 0  
 Actuated Coord No Timing Plan 0  
 Actuated Walk Rest No Sequence 0  
 Phase Reservice No Action Plan 0  
 Max Select None Force Off None

**Split Preference Phases**

Phase	1	2	3	4	5	6	7	8	9	10	11	12	13	14	15	16
Description	N	S-T	E-L	W-T	N	N-T	W-L	E-T	N	N	N	N	N	N	N	N
Splits (Split Pat 4)	0	36	12	22	0	36	12	22	0	0	0	0	0	0	0	0
Pref 1	0	0	0	0	0	0	0	0	0	0	0	0	0	0	0	0
Pref 2	0	0	0	0	0	0	0	0	0	0	0	0	0	0	0	0

Ring	1	2	3	4
Ring Split Ext	0	0	0	0
Ring Displacement	-	0	0	0
Split Sum	70s	70s	0s	0s

Misc. Data  
 Veh Perm 1 0 Veh Perm 2 0 Veh Perm 2 Disp 0  
 Split Demand 0 Split Demand 0 Crossing Arterial 0  
 Pat 1 Pat 2 Pat

**Split Pattern**

Phase	1	2	3	4	5	6	7	8	9	10	11	12	13	14	15	16
Coord Phase		X				X										
Vehicle Recall																
Pedestrian Recall																
Recall to Max. Time																
Omit Phase									X	X	X	X	X	X	X	X
Special Function Outputs																

**Coordinator Pattern # 5**

Split Pattern 5 TS2 (Pat-Off) 1-2 Splits In Seconds  
 Cycle 190 Std (COS) 41 Offsets In Seconds  
 Offset Value 57s Dwell/Add Time 0  
 Actuated Coord No Timing Plan 1  
 Actuated Walk Rest No Sequence 1  
 Phase Reservice No Action Plan 0  
 Max Select None Force Off None

**Split Preference Phases**

Phase	1	2	3	4	5	6	7	8	9	10	11	12	13	14	15	16
Description	N	S-T	E-L	W-T	N	N-T	W-L	E-T	N	N	N	N	N	N	N	N
Splits (Split Pat 5)	0	106	20	64	0	106	20	64	0	0	0	0	0	0	0	0
Pref 1	0	0	0	0	0	0	0	0	0	0	0	0	0	0	0	0
Pref 2	0	0	0	0	0	0	0	0	0	0	0	0	0	0	0	0

Ring	1	2	3	4
Ring Split Ext	0	0	0	0
Ring Displacement	-	0	0	0
Split Sum	190s	190s	0s	0s

Misc. Data  
 Veh Perm 1 0 Veh Perm 2 0 Veh Perm 2 Disp 0  
 Split Demand 0 Split Demand 0 Crossing Arterial 0  
 Pat 1 Pat 2 Pat

**Split Pattern**

Phase	1	2	3	4	5	6	7	8	9	10	11	12	13	14	15	16
Coord Phase		X				X										
Vehicle Recall																
Pedestrian Recall																
Recall to Max. Time																
Omit Phase									X	X	X	X	X	X	X	X
Special Function Outputs																

**Coordinator Pattern # 6**

Split Pattern 6 TS2 (Pat-Off) 1-3 Splits In Seconds  
 Cycle 170 Std (COS) 73 Offsets In Seconds  
 Offset Value 39s Dwell/Add Time 0  
 Actuated Coord No Timing Plan 1  
 Actuated Walk Rest No Sequence 1  
 Phase Reservice No Action Plan 0  
 Max Select None Force Off None

**Split Preference Phases**

Phase	1	2	3	4	5	6	7	8	9	10	11	12	13	14	15	16
Description	N	S-T	E-L	W-T	N	N-T	W-L	E-T	N	N	N	N	N	N	N	N
Splits (Split Pat 6)	0	108	18	44	0	108	18	44	0	0	0	0	0	0	0	0
Pref 1	0	0	0	0	0	0	0	0	0	0	0	0	0	0	0	0
Pref 2	0	0	0	0	0	0	0	0	0	0	0	0	0	0	0	0

Ring	1	2	3	4
Ring Split Ext	0	0	0	0
Ring Displacement	-	0	0	0
Split Sum	170s	170s	0s	0s

Misc. Data  
 Veh Perm 1 0 Veh Perm 2 0 Veh Perm 2 Disp 0  
 Split Demand 0 Split Demand 0 Crossing Arterial 0  
 Pat 1 Pat 2 Pat

**Split Pattern**

Phase	1	2	3	4	5	6	7	8	9	10	11	12	13	14	15	16
Coord Phase		X				X										
Vehicle Recall																
Pedestrian Recall																
Recall to Max. Time																
Omit Phase									X	X	X	X	X	X	X	X
Special Function Outputs																

**Coordinator Pattern # 7**

Split Pattern 7 TS2 (Pat-Off) 2-1 Splits In Seconds  
 Cycle 190 Std (COS) 81 Offsets In Seconds  
 Offset Value 24s Dwell/Add Time 0  
 Actuated Coord No Timing Plan 1  
 Actuated Walk Rest No Sequence 1  
 Phase Reservice No Action Plan 0  
 Max Select None Force Off None

**Split Preference Phases**

Phase	1	2	3	4	5	6	7	8	9	10	11	12	13	14	15	16
Description	N	S-T	E-L	W-T	N	N-T	W-L	E-T	N	N	N	N	N	N	N	N
Splits (Split Pat 7)	0	110	25	55	0	110	25	55	0	0	0	0	0	0	0	0
Pref 1	0	0	0	0	0	0	0	0	0	0	0	0	0	0	0	0
Pref 2	0	0	0	0	0	0	0	0	0	0	0	0	0	0	0	0

Ring	1	2	3	4
Ring Split Ext	0	0	0	0
Ring Displacement	-	0	0	0
Split Sum	190s	190s	0s	0s

Misc. Data  
 Veh Perm 1 0 Veh Perm 2 0 Veh Perm 2 Disp 0  
 Split Demand 0 Split Demand 0 Crossing Arterial 0  
 Pat 1 Pat 2 Pat

**Split Pattern**

Phase	1	2	3	4	5	6	7	8	9	10	11	12	13	14	15	16
Coord Phase		X				X										
Vehicle Recall																
Pedestrian Recall																
Recall to Max. Time																
Omit Phase									X	X	X	X	X	X	X	X
Special Function Outputs																

**Coordinator Pattern # 8**

Split Pattern 8 TS2 (Pat-Off) 2-2 Splits In Seconds  
 Cycle 100 Std (COS) 89 Offsets In Seconds  
 Offset Value 42s Dwell/Add Time 0  
 Actuated Coord No Timing Plan 0  
 Actuated Walk Rest No Sequence 0  
 Phase Reservice No Action Plan 0  
 Max Select None Force Off None

**Split Preference Phases**

Phase	1	2	3	4	5	6	7	8	9	10	11	12	13	14	15	16
Description	N	S-T	E-L	W-T	N	N-T	W-L	E-T	N	N	N	N	N	N	N	N
Splits (Split Pat 8)	0	63	15	22	0	63	15	22	0	0	0	0	0	0	0	0
Pref 1	0	0	0	0	0	0	0	0	0	0	0	0	0	0	0	0
Pref 2	0	0	0	0	0	0	0	0	0	0	0	0	0	0	0	0

Ring	1	2	3	4
Ring Split Ext	0	0	0	0
Ring Displacement	-	0	0	0
Split Sum	100s	100s	0s	0s

Misc. Data  
 Veh Perm 1 0 Veh Perm 2 0 Veh Perm 2 Disp 0  
 Split Demand 0 Split Demand 0 Crossing Arterial Pat 0  
 Pat 1 Pat 2 Pat

**Split Pattern**

Phase	1	2	3	4	5	6	7	8	9	10	11	12	13	14	15	16
Coord Phase		X				X										
Vehicle Recall																
Pedestrian Recall																
Recall to Max. Time																
Omit Phase									X	X	X	X	X	X	X	X
Special Function Outputs																

**Coordinator Pattern # 12**

Split Pattern 12 TS2 (Pat-Off) 3-3 Splits In Seconds  
 Cycle 80 Std (COS) 145 Offsets In Seconds  
 Offset Value 84s Dwell/Add Time 0  
 Actuated Coord No Timing Plan 1  
 Actuated Walk Rest No Sequence 1  
 Phase Reservice No Action Plan 0  
 Max Select None Force Off None

**Split Preference Phases**

Phase	1	2	3	4	5	6	7	8	9	10	11	12	13	14	15	16
Description	N	S-T	E-L	W-T	N	N-T	W-L	E-T	N	N	N	N	N	N	N	N
Splits (Split Pat 12)	0	46	12	22	0	46	12	22	0	0	0	0	0	0	0	0
Pref 1	0	0	0	0	0	0	0	0	0	0	0	0	0	0	0	0
Pref 2	0	0	0	0	0	0	0	0	0	0	0	0	0	0	0	0

Ring	1	2	3	4
Ring Split Ext	0	0	0	0
Ring Displacement	-	0	0	0
Split Sum	80s	80s	0s	0s

Misc. Data  
 Veh Perm 1 0 Veh Perm 2 0 Veh Perm 2 Disp 0  
 Split Demand 0 Split Demand 0 Crossing Arterial Pat 0  
 Pat 1 Pat 2 Pat

**Split Pattern**

Phase	1	2	3	4	5	6	7	8	9	10	11	12	13	14	15	16
Coord Phase		X				X										
Vehicle Recall																
Pedestrian Recall																
Recall to Max. Time																
Omit Phase									X	X	X	X	X	X	X	X
Special Function Outputs																



**Coordinator Pattern # 14**

Split Pattern	14	TS2 (Pat-Off)	4-2	Splits In	Seconds
Cycle	75	Std (COS)	161	Offsets In	Seconds
Offset Value	68s	Dwell/Add Time	0		
Actuated Coord No		Timing Plan	1		
Actuated Walk Rest	No	Sequence	1		
Phase Reservice	No	Action Plan	0		
Max Select	None	Force Off	None		

**Split Preference Phases**

Phase	1	2	3	4	5	6	7	8	9	10	11	12	13	14	15	16
Description	N	S-T	E-L	W-T	N	N-T	W-L	E-T	N	N	N	N	N	N	N	N
Splits (Split Pat 14)	0	41	12	22	0	41	12	22	0	0	0	0	0	0	0	0
Pref 1	0	0	0	0	0	0	0	0	0	0	0	0	0	0	0	0
Pref 2	0	0	0	0	0	0	0	0	0	0	0	0	0	0	0	0

Ring	1	2	3	4
Ring Split Ext	0	0	0	0
Ring Displacement	-	0	0	0
Split Sum	75s	75s	0s	0s

Misc. Data  
 Veh Perm 1 0 Veh Perm 2 0 Veh Perm 2 Disp 0  
 Split Demand 0 Split Demand 0 Crossing Arterial 0  
 Pat 1 Pat 2 Pat

**Split Pattern**

Phase	1	2	3	4	5	6	7	8	9	10	11	12	13	14	15	16
Coord Phase		X				X										
Vehicle Recall																
Pedestrian Recall																
Recall to Max. Time																
Omit Phase									X	X	X	X	X	X	X	X
Special Function Outputs																

Miami-Dade, FL



2627 - LeJeune Rd & University Dr - 2070-1C - Econolite Type - Cobalt

**Time Base Action Plan  
Action Plan (MM) 5-2**

**Action Plan - 1 - "1"**

Pattern Auto Override Sys No  
 Timing Plan 0 Sequence 0  
 Veh Detector Plan 0 Det Log None  
 Flash No Red Rest No  
 Veh Det Diag 2 Ped Det Diag 0  
 Plan Plan  
 Dimming Enable No Pmt Veh Priority No  
 Ret Ret  
 Pmt Ped Priority No Pmt Queue Delay No  
 Ret  
 Pmt Cond Delay No

Phase	1	2	3	4	5	6	7	8	9	10	11	12	13	14	15	16
Ped Recall																
Walk 2																
Veh Ext 2																
Veh Recall																
Max Recall																
Max 2																
Max 3																
CS Inhibit																
Omit																

Spec Func (1-8)									
-----------------	--	--	--	--	--	--	--	--	--

Aux Func (1-3)			
----------------	--	--	--

	1	2	3	4	5	6	7	8	9	10	11	12	13	14	15
LP 1-15	.	.	.	.	.	.	.	.	.	.	.	.	.	.	.
LP 16-30	.	.	.	.	.	.	.	.	.	.	.	.	.	.	.
LP 31-45	.	.	.	.	.	.	.	.	.	.	.	.	.	.	.
LP 46-60	.	.	.	.	.	.	.	.	.	.	.	.	.	.	.
LP 61-75	.	.	.	.	.	.	.	.	.	.	.	.	.	.	.
LP 76-90	.	.	.	.	.	.	.	.	.	.	.	.	.	.	.
LP 91-100	.	.	.	.	.	.	.	.	.	.	.	.	.	.	.

**Action Plan - 3 - "3"**

Pattern 3 Override Sys No  
 Timing Plan 0 Sequence 0  
 Veh Detector Plan 0 Det Log None  
 Flash No Red Rest No  
 Veh Det Diag 0 Ped Det Diag 0  
 Plan Plan  
 Dimming Enable No Pmt Veh Priority No  
 Ret Ret  
 Pmt Ped Priority No Pmt Queue Delay No  
 Ret  
 Pmt Cond Delay No

Phase	1	2	3	4	5	6	7	8	9	10	11	12	13	14	15	16
Ped Recall																
Walk 2																
Veh Ext 2																
Veh Recall																
Max Recall																
Max 2																
Max 3																
CS Inhibit																
Omit																
Spec Func (1-8)																
Aux Func (1-3)																
	1	2	3	4	5	6	7	8	9	10	11	12	13	14	15	
LP 1-15	.	.	.	.	.	.	.	.	.	.	.	.	.	.	.	.
LP 16-30	.	.	.	.	.	.	.	.	.	.	.	.	.	.	.	.
LP 31-45	.	.	.	.	.	.	.	.	.	.	.	.	.	.	.	.
LP 46-60	.	.	.	.	.	.	.	.	.	.	.	.	.	.	.	.
LP 61-75	.	.	.	.	.	.	.	.	.	.	.	.	.	.	.	.
LP 76-90	.	.	.	.	.	.	.	.	.	.	.	.	.	.	.	.
LP 91-100	.	.	.	.	.	.	.	.	.	.	.	.	.	.	.	.

**Action Plan - 4 - "4"**

Pattern 4 Override Sys No  
 Timing Plan 0 Sequence 0  
 Veh Detector Plan 0 Det Log None  
 Flash No Red Rest No  
 Veh Det Diag 0 Ped Det Diag 0  
 Plan Plan  
 Dimming Enable No Pmt Veh Priority No  
 Ret Ret  
 Pmt Ped Priority No Pmt Queue Delay No  
 Ret  
 Pmt Cond Delay No

Phase	1	2	3	4	5	6	7	8	9	10	11	12	13	14	15	16
Ped Recall																
Walk 2																
Veh Ext 2																
Veh Recall																
Max Recall																
Max 2																
Max 3																
CS Inhibit																
Omit																
Spec Func (1-8)																
Aux Func (1-3)																
	1	2	3	4	5	6	7	8	9	10	11	12	13	14	15	
LP 1-15	.	.	.	.	.	.	.	.	.	.	.	.	.	.	.	.
LP 16-30	.	.	.	.	.	.	.	.	.	.	.	.	.	.	.	.
LP 31-45	.	.	.	.	.	.	.	.	.	.	.	.	.	.	.	.
LP 46-60	.	.	.	.	.	.	.	.	.	.	.	.	.	.	.	.
LP 61-75	.	.	.	.	.	.	.	.	.	.	.	.	.	.	.	.
LP 76-90	.	.	.	.	.	.	.	.	.	.	.	.	.	.	.	.
LP 91-100	.	.	.	.	.	.	.	.	.	.	.	.	.	.	.	.

**Action Plan - 5 - "5"**

Pattern 5 Override Sys No  
 Timing Plan 0 Sequence 1  
 Veh Detector Plan 0 Det Log None  
 Flash No Red Rest No  
 Veh Det Diag 2 Ped Det Diag 0  
 Plan Plan  
 Dimming Enable No Pmt Veh Priority No  
 Ret Ret  
 Pmt Ped Priority No Pmt Queue Delay No  
 Ret  
 Pmt Cond Delay No

Phase	1	2	3	4	5	6	7	8	9	10	11	12	13	14	15	16
Ped Recall																
Walk 2																
Veh Ext 2																
Veh Recall																
Max Recall																
Max 2																
Max 3																
CS Inhibit																
Omit																
Spec Func (1-8)																
Aux Func (1-3)																
	1	2	3	4	5	6	7	8	9	10	11	12	13	14	15	
LP 1-15	.	.	.	.	.	.	.	.	.	.	.	.	.	.	.	.
LP 16-30	.	.	.	.	.	.	.	.	.	.	.	.	.	.	.	.
LP 31-45	.	.	.	.	.	.	.	.	.	.	.	.	.	.	.	.
LP 46-60	.	.	.	.	.	.	.	.	.	.	.	.	.	.	.	.
LP 61-75	.	.	.	.	.	.	.	.	.	.	.	.	.	.	.	.
LP 76-90	.	.	.	.	.	.	.	.	.	.	.	.	.	.	.	.
LP 91-100	.	.	.	.	.	.	.	.	.	.	.	.	.	.	.	.

**Action Plan - 6 - "6"**

Pattern 6 Override Sys No  
 Timing Plan 0 Sequence 1  
 Veh Detector Plan 0 Det Log None  
 Flash No Red Rest No  
 Veh Det Diag 2 Ped Det Diag 0  
 Plan Plan  
 Dimming Enable No Pmt Veh Priority No  
 Ret Ret  
 Pmt Ped Priority No Pmt Queue Delay No  
 Ret  
 Pmt Cond Delay No

Phase	1	2	3	4	5	6	7	8	9	10	11	12	13	14	15	16
Ped Recall																
Walk 2																
Veh Ext 2																
Veh Recall																
Max Recall																
Max 2																
Max 3																
CS Inhibit																
Omit																
Spec Func (1-8)																
Aux Func (1-3)																
	1	2	3	4	5	6	7	8	9	10	11	12	13	14	15	
LP 1-15	.	.	.	.	.	.	.	.	.	.	.	.	.	.	.	.
LP 16-30	.	.	.	.	.	.	.	.	.	.	.	.	.	.	.	.
LP 31-45	.	.	.	.	.	.	.	.	.	.	.	.	.	.	.	.
LP 46-60	.	.	.	.	.	.	.	.	.	.	.	.	.	.	.	.
LP 61-75	.	.	.	.	.	.	.	.	.	.	.	.	.	.	.	.
LP 76-90	.	.	.	.	.	.	.	.	.	.	.	.	.	.	.	.
LP 91-100	.	.	.	.	.	.	.	.	.	.	.	.	.	.	.	.

**Action Plan - 7 - "7"**

Pattern 7 Override Sys No  
 Timing Plan 0 Sequence 1  
 Veh Detector Plan 0 Det Log None  
 Flash No Red Rest No  
 Veh Det Diag 2 Ped Det Diag 0  
 Plan Plan  
 Dimming Enable No Pmt Veh Priority No  
 Ret Ret  
 Pmt Ped Priority No Pmt Queue Delay No  
 Ret  
 Pmt Cond Delay No

Phase	1	2	3	4	5	6	7	8	9	10	11	12	13	14	15	16
Ped Recall																
Walk 2																
Veh Ext 2																
Veh Recall																
Max Recall																
Max 2																
Max 3																
CS Inhibit																
Omit																
Spec Func (1-8)																
Aux Func (1-3)																
	1	2	3	4	5	6	7	8	9	10	11	12	13	14	15	
LP 1-15	.	.	.	.	.	.	.	.	.	.	.	.	.	.	.	.
LP 16-30	.	.	.	.	.	.	.	.	.	.	.	.	.	.	.	.
LP 31-45	.	.	.	.	.	.	.	.	.	.	.	.	.	.	.	.
LP 46-60	.	.	.	.	.	.	.	.	.	.	.	.	.	.	.	.
LP 61-75	.	.	.	.	.	.	.	.	.	.	.	.	.	.	.	.
LP 76-90	.	.	.	.	.	.	.	.	.	.	.	.	.	.	.	.
LP 91-100	.	.	.	.	.	.	.	.	.	.	.	.	.	.	.	.

**Action Plan - 8 - "8"**

Pattern 8 Override Sys No  
 Timing Plan 0 Sequence 0  
 Veh Detector Plan 0 Det Log None  
 Flash No Red Rest No  
 Veh Det Diag 0 Ped Det Diag 0  
 Plan Plan  
 Dimming Enable No Pmt Veh Priority No  
 Ret Ret  
 Pmt Ped Priority No Pmt Queue Delay No  
 Ret  
 Pmt Cond Delay No

Phase	1	2	3	4	5	6	7	8	9	10	11	12	13	14	15	16
Ped Recall																
Walk 2																
Veh Ext 2																
Veh Recall																
Max Recall																
Max 2																
Max 3																
CS Inhibit																
Omit																
Spec Func (1-8)																
Aux Func (1-3)																
	1	2	3	4	5	6	7	8	9	10	11	12	13	14	15	
LP 1-15	.	.	.	.	.	.	.	.	.	.	.	.	.	.	.	.
LP 16-30	.	.	.	.	.	.	.	.	.	.	.	.	.	.	.	.
LP 31-45	.	.	.	.	.	.	.	.	.	.	.	.	.	.	.	.
LP 46-60	.	.	.	.	.	.	.	.	.	.	.	.	.	.	.	.
LP 61-75	.	.	.	.	.	.	.	.	.	.	.	.	.	.	.	.
LP 76-90	.	.	.	.	.	.	.	.	.	.	.	.	.	.	.	.
LP 91-100	.	.	.	.	.	.	.	.	.	.	.	.	.	.	.	.

**Action Plan - 12 - "12"**

Pattern 12 Override Sys No  
 Timing Plan 0 Sequence 1  
 Veh Detector Plan 0 Det Log None  
 Flash No Red Rest No  
 Veh Det Diag 2 Ped Det Diag 0  
 Plan Plan  
 Dimming Enable No Pmt Veh Priority No  
 Ret Ret  
 Pmt Ped Priority No Pmt Queue Delay No  
 Ret  
 Pmt Cond Delay No

Phase	1	2	3	4	5	6	7	8	9	10	11	12	13	14	15	16
Ped Recall																
Walk 2																
Veh Ext 2																
Veh Recall																
Max Recall																
Max 2																
Max 3																
CS Inhibit																
Omit																

Spec Func (1-8)																
-----------------	--	--	--	--	--	--	--	--	--	--	--	--	--	--	--	--

Aux Func (1-3)																
----------------	--	--	--	--	--	--	--	--	--	--	--	--	--	--	--	--

	1	2	3	4	5	6	7	8	9	10	11	12	13	14	15
LP 1-15	.	.	.	.	.	.	.	.	.	.	.	.	.	.	.
LP 16-30	.	.	.	.	.	.	.	.	.	.	.	.	.	.	.
LP 31-45	.	.	.	.	.	.	.	.	.	.	.	.	.	.	.
LP 46-60	.	.	.	.	.	.	.	.	.	.	.	.	.	.	.
LP 61-75	.	.	.	.	.	.	.	.	.	.	.	.	.	.	.
LP 76-90	.	.	.	.	.	.	.	.	.	.	.	.	.	.	.
LP 91-100	.	.	.	.	.	.	.	.	.	.	.	.	.	.	.

**Action Plan - 14 - "14"**

Pattern 14 Override Sys No  
 Timing Plan 0 Sequence 1  
 Veh Detector Plan 0 Det Log None  
 Flash No Red Rest No  
 Veh Det Diag 2 Ped Det Diag 0  
 Plan Plan  
 Dimming Enable No Pmt Veh Priority No  
 Ret Ret  
 Pmt Ped Priority No Pmt Queue Delay No  
 Ret  
 Pmt Cond Delay No

Phase	1	2	3	4	5	6	7	8	9	10	11	12	13	14	15	16
Ped Recall																
Walk 2																
Veh Ext 2																
Veh Recall																
Max Recall																
Max 2																
Max 3																
CS Inhibit																
Omit																

Spec Func (1-8)																
-----------------	--	--	--	--	--	--	--	--	--	--	--	--	--	--	--	--

Aux Func (1-3)																
----------------	--	--	--	--	--	--	--	--	--	--	--	--	--	--	--	--

	1	2	3	4	5	6	7	8	9	10	11	12	13	14	15
LP 1-15	.	.	.	.	.	.	.	.	.	.	.	.	.	.	.
LP 16-30	.	.	.	.	.	.	.	.	.	.	.	.	.	.	.
LP 31-45	.	.	.	.	.	.	.	.	.	.	.	.	.	.	.
LP 46-60	.	.	.	.	.	.	.	.	.	.	.	.	.	.	.
LP 61-75	.	.	.	.	.	.	.	.	.	.	.	.	.	.	.
LP 76-90	.	.	.	.	.	.	.	.	.	.	.	.	.	.	.
LP 91-100	.	.	.	.	.	.	.	.	.	.	.	.	.	.	.

**Action Plan - 37 - "37"**

Pattern 7 Override Sys No  
 Timing Plan 0 Sequence 1  
 Veh Detector Plan 0 Det Log None  
 Flash No Red Rest No  
 Veh Det Diag 0 Ped Det Diag 0  
 Plan Plan  
 Dimming Enable No Pmt Veh Priority No  
 Ret Ret  
 Pmt Ped Priority No Pmt Queue Delay No  
 Ret  
 Pmt Cond Delay No

Phase	1	2	3	4	5	6	7	8	9	10	11	12	13	14	15	16
Ped Recall																
Walk 2																
Veh Ext 2																
Veh Recall							X									
Max Recall																
Max 2																
Max 3																
CS Inhibit																
Omit																
Spec Func (1-8)																
Aux Func (1-3)																
	1	2	3	4	5	6	7	8	9	10	11	12	13	14	15	
LP 1-15	.	.	.	.	.	.	.	.	.	.	.	.	.	.	.	.
LP 16-30	.	.	.	.	.	.	.	.	.	.	.	.	.	.	.	.
LP 31-45	.	.	.	.	.	.	.	.	.	.	.	.	.	.	.	.
LP 46-60	.	.	.	.	.	.	.	.	.	.	.	.	.	.	.	.
LP 61-75	.	.	.	.	.	.	.	.	.	.	.	.	.	.	.	.
LP 76-90	.	.	.	.	.	.	.	.	.	.	.	.	.	.	.	.
LP 91-100	.	.	.	.	.	.	.	.	.	.	.	.	.	.	.	.

**Action Plan - 62 - "62"**

Pattern Free Override Sys No  
 Timing Plan 0 Sequence 0  
 Veh Detector Plan 0 Det Log None  
 Flash No Red Rest No  
 Veh Det Diag 0 Ped Det Diag 0  
 Plan Plan  
 Dimming Enable No Pmt Veh Priority No  
 Ret Ret  
 Pmt Ped Priority No Pmt Queue Delay No  
 Ret  
 Pmt Cond Delay No

Phase	1	2	3	4	5	6	7	8	9	10	11	12	13	14	15	16
Ped Recall																
Walk 2																
Veh Ext 2																
Veh Recall																
Max Recall																
Max 2																
Max 3																
CS Inhibit																
Omit																
Spec Func (1-8)																
Aux Func (1-3)																
	1	2	3	4	5	6	7	8	9	10	11	12	13	14	15	
LP 1-15	.	.	.	.	.	.	.	.	.	.	.	.	.	.	.	.
LP 16-30	.	.	.	.	.	.	.	.	.	.	.	.	.	.	.	.
LP 31-45	.	.	.	.	.	.	.	.	.	.	.	.	.	.	.	.
LP 46-60	.	.	.	.	.	.	.	.	.	.	.	.	.	.	.	.
LP 61-75	.	.	.	.	.	.	.	.	.	.	.	.	.	.	.	.
LP 76-90	.	.	.	.	.	.	.	.	.	.	.	.	.	.	.	.
LP 91-100	.	.	.	.	.	.	.	.	.	.	.	.	.	.	.	.

**Action Plan - 63 - "63"**

Pattern Flash Override Sys No  
 Timing Plan 0 Sequence 0  
 Veh Detector Plan 0 Det Log None  
 Flash No Red Rest No  
 Veh Det Diag 0 Ped Det Diag 0  
 Plan Plan  
 Dimming Enable No Pmt Veh Priority No  
 Ret Ret  
 Pmt Ped Priority No Pmt Queue Delay No  
 Ret  
 Pmt Cond Delay No

Phase	1	2	3	4	5	6	7	8	9	10	11	12	13	14	15	16
Ped Recall																
Walk 2																
Veh Ext 2																
Veh Recall																
Max Recall																
Max 2																
Max 3																
CS Inhibit																
Omit																

Spec Func (1-8)									
-----------------	--	--	--	--	--	--	--	--	--

Aux Func (1-3)			
----------------	--	--	--

	1	2	3	4	5	6	7	8	9	10	11	12	13	14	15
LP 1-15	.	.	.	.	.	.	.	.	.	.	.	.	.	.	.
LP 16-30	.	.	.	.	.	.	.	.	.	.	.	.	.	.	.
LP 31-45	.	.	.	.	.	.	.	.	.	.	.	.	.	.	.
LP 46-60	.	.	.	.	.	.	.	.	.	.	.	.	.	.	.
LP 61-75	.	.	.	.	.	.	.	.	.	.	.	.	.	.	.
LP 76-90	.	.	.	.	.	.	.	.	.	.	.	.	.	.	.
LP 91-100	.	.	.	.	.	.	.	.	.	.	.	.	.	.	.



Miami-Dade, FL



2627 - LeJeune Rd &amp; University Dr - 2070-1C - Econolite Type - Cobalt

**Time Base Day Plan/Schedule  
Day Plan (MM) 5-3****Day Plan #1 - "1"**

Event	Action Plan	Start Time
1	14	00:00
2	62	00:30
3	14	05:00
4	5	06:00
5	6	10:30
6	7	15:30
7	37	16:00
8	7	18:30
9	12	20:00
10	14	21:00

**Day Plan #2 - "2"**

Event	Action Plan	Start Time
1	14	00:00
2	62	01:00
3	14	05:00
4	6	10:00
5	14	22:00

**Schedule (MM) 5-4****Schedule Number - 1**

Day Plan No.: 1

Month	JAN	FEB	MAR	APR	MAY	JUN	JUL	AUG	SEP	OCT	NOV	DEC
	X	X	X	X	X	X	X	X	X	X	X	X

Day (DOW)	SUN	MON	TUE	WED	THU	FRI	SAT
		X	X	X	X	X	

Day (DOM)	1	2	3	4	5	6	7	8	9	10	11
	X	X	X	X	X	X	X	X	X	X	X
	12	13	14	15	16	17	18	19	20	21	22
	X	X	X	X	X	X	X	X	X	X	X
	23	24	25	26	27	28	29	30	31		
	X	X	X	X	X	X	X	X	X		

**Schedule Number - 2**

Day Plan No.: 2

Month	JAN	FEB	MAR	APR	MAY	JUN	JUL	AUG	SEP	OCT	NOV	DEC
	X	X	X	X	X	X	X	X	X	X	X	X

Day (DOW)	SUN	MON	TUE	WED	THU	FRI	SAT
	X						X

Day (DOM)	1	2	3	4	5	6	7	8	9	10	11
	X	X	X	X	X	X	X	X	X	X	X
	12	13	14	15	16	17	18	19	20	21	22
	X	X	X	X	X	X	X	X	X	X	X
	23	24	25	26	27	28	29	30	31		
	X	X	X	X	X	X	X	X	X		

# SIGNAL OPERATING PLAN



Timing Phases	Direction	NB	SB	E/B		W/B		Ped Heads				Movements/Display/Actuation	
	Head No.	2	6	3/8	8	7/4	4	P2	P6	P4	P8		
2+6 N/S LE JEUNE Rd RECALL	Dwell	G	G	R	R	R	R						
	Clear to	3+7	Y	Y	R	R	R	R	DW	DW	DW		DW
		3+8	Y	Y	R	R	R	R	DW	DW	DW		DW
		4+7	Y	Y	R	R	R	R	DW	DW	DW		DW
		4+8	Y	Y	R	R	R	R	DW	DW	DW		DW
3+7 EL+WL UNIVERSITY DR ACTUATED	Dwell	R	R	←/R	R	←/R	R						
	Clear to	3+8	R	R	←/R	R	←/R	R	DW	DW	DW		DW
		4+7	R	R	←/R	R	←/R	R	DW	DW	DW		DW
		4+8	R	R	←/R	R	←/R	R	DW	DW	DW		DW
		2+6	R	R	←/R	R	←/R	R	DW	DW	DW		DW
3+8 WB UNIVERSITY DR ACTUATED	Dwell	R	R	←/G	G	R	R	DW	DW	DW	W/F		
	Clear to	4+8	R	R	←/G	G	R	R	DW	DW	DW		DW
		2+6	R	R	←/Y	Y	R	R	DW	DW	DW		DW
4+7 EB UNIVERSITY DR ACTUATED	Dwell	R	R	R	R	←/G	G	DW	DW	W/F	DW		
	Clear to	4+8	R	R	R	R	←/G	G	DW	DW	DW		DW
		2+6	R	R	R	R	←/Y	Y	DW	DW	DW		DW
4+8 E/W UNIVERSITY DR ACTUATED	Dwell	R	R	G	G	G	G	DW	DW	W/F	W/F		
	Clear to	2+6	R	R	Y	Y	Y	Y	DW	DW	DW		DW
	Dwell												
	Clear to												

Flashing Operation

FY FY FR FR FR FR

Page 1 of 1

## Miami-Dade County Public Works Department

Drawn H. FRANCILLON	Date 3/20/07	LE JEUNE Rd & UNIVERSITY DR		
Checked H. HERWANDER	Date 7/2/07	Placed in Service Date	Phasing No. 6	Asset Number 2627
		By SSI		

## TOD Schedule Report

for 4749: Salzedo St&University Dr

Print Date:  
9/24/2019

Print Time:  
9:24 PM

<u>Asset</u>	<u>Intersection</u>	<u>TOD Schedule</u>	<u>Op Mode</u>	<u>Plan #</u>	<u>Cycle</u>	<u>Offset</u>	<u>TOD Setting</u>	<u>Active PhaseBank</u>	<u>Active Maximum</u>
4749	Salzedo St&University Dr	DOW-3		N/A	0	0	N/A	0	Max 0

### Splits

<u>PH 1</u>	<u>PH 2</u>	<u>PH 3</u>	<u>PH 4</u>	<u>PH 5</u>	<u>PH 6</u>	<u>PH 7</u>	<u>PH 8</u>
-	SWT	-	NBT	-	NET	-	SBT
0	0	0	0	0	0	0	0
↓		↑		↑		↓	

Active Phase Bank: Phase Bank 1

<u>Phase</u>	<u>Walk</u>			<u>Don't Walk</u>			<u>Min Initial</u>			<u>Veh Ext</u>			<u>Max Limit</u>			<u>Max 2</u>			<u>Yellow</u>	<u>Red</u>
	<u>Phase Bank</u>																			
	1	2	3	1	2	3	1	2	3	1	2	3	1	2	3	1	2	3		
1 -	0	0	0	0	0	0	0	0	0	0	0	0	0	0	0	0	0	0	0	0
2 SWT	0	0	0	0	0	0	12	12	12	1	1	1	30	30	30	0	0	0	4	2.4
3 -	0	0	0	0	0	0	0	0	0	0	0	0	0	0	0	0	0	0	0	0
4 NBT	0	0	0	0	0	0	7	7	7	4	-2.5	-2.5	20	20	20	81	0	0	4	2.2
5 -	0	0	0	0	0	0	0	0	0	0	0	0	0	0	0	0	0	0	0	0
6 NET	0	0	0	0	0	0	12	12	12	1	1	1	30	30	30	0	0	0	4	2.4
7 -	0	0	0	0	0	0	0	0	0	0	0	0	0	0	0	0	0	0	0	0
8 SBT	0	0	0	0	0	0	7	7	7	4	-2.5	-2.5	20	20	20	81	0	0	4	2.2

Last In Service Date: unknown

<u>Permitted Phases</u>	
<b>12345678</b>	
Default	-2-4-6-8
External Permit 0	-2-4-6-8
External Permit 1	-2-4-6-8
External Permit 2	-2-4-6-8

<u>Current TOD Schedule</u>	<u>Plan</u>	<u>Cycle</u>	<u>Green Time</u>								<u>Ring Offset</u>	<u>Offset</u>
			1	2	3	4	5	6	7	8		
			-	SWT	-	NBT	-	NET	-	SBT		
5		95	0	50	0	33	0	50	0	33	0	73
6		85	0	39	0	34	0	39	0	34	0	44
7		190	0	99	0	79	0	99	0	79	0	99
14		75	0	44	0	19	0	44	0	19	0	67

<u>Local TOD Schedule</u>		
<u>Time</u>	<u>Plan</u>	<u>DOW</u>
0000	Free	Su M T W Th F S
0600	14	Su S
0600	5	M T W Th F
1000	6	Su S
1030	6	M T W Th F
1530	7	M T W Th F
2000	Free	M T W Th F
2200	Free	Su S

**TOD Schedule Report**  
**for 4749: Salzedo St&University Dr**

Print Date:  
**9/24/2019**

Print Time:  
**9:24 PM**

<b>Current Time of Day Function</b>			
<u>Time</u>	<u>Function</u>	<u>Settings *</u>	<u>Day of Week</u>
0000	TOD OUTPUTS	-----	SuM T W ThF S

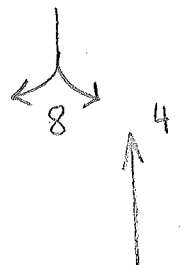
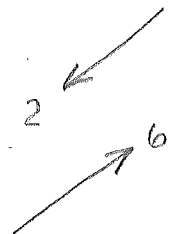
<b>Local Time of Day Function</b>			
<u>Time</u>	<u>Function</u>	<u>Settings *</u>	<u>Day of Week</u>
0000	TOD OUTPUTS	-----	SuM T W ThF S

<b>* Settings</b>
Blank - FREE - Phase Bank 1, Max 1
Blank - Plan - Phase Bank 1, Max 2
1 - Phase Bank 2, Max 1
2 - Phase Bank 2, Max 2
3 - Phase Bank 3, Max 1
4 - Phase Bank 3, Max 2
5 - EXTERNAL PERMIT 1
6 - EXTERNAL PERMIT 2
7 - X-PED OMIT
8 - TBA

<b><i>No Calendar Defined/Enabled</i></b>
---

# SIGNAL OPERATING PLAN

		SIGNAL HEAD NUMBER						
PHASE	INT	2	4	6	8			
$\phi(2+6)$ UNIVERSITY  (RECALL)	R/W	G	R	G	R			
	4+8	Y	R	Y	R			
	TO							
	CLEAR							
$\phi(4+8)$ SALZEDO  (ACTUATED)	R/W	R	G	R	G			
	2+6	R	Y	R	Y			
	TO							
	CLEAR							
	R/W							
	TO							
	CLEAR							
	R/W							
	TO							
	CLEAR							
FLASH. OPER. →		Y	R	Y	R			



<b>Drawn</b> H. HERNANDEZ	<b>Date</b> 9/29/95	<b>METROPOLITAN DADE COUNTY DEPARTMENT OF PUBLIC WORKS</b>	
<b>Check</b> F. PRATS	<b>Date</b> 9/29/95	<b>ASSET NO:</b> 4749	
<b>Division Engineer</b>	<b>Date</b>	SALZEDO ST & UNIVERSITY DR	
		<b>Placed in Service</b>	<b>Phasing Number</b>
		Date: 11/13/95 By: W.O. 4092	2

# Scenario 1 - AM

# Signal Timing

## 3: Salzedo St. & University Dr.

09/20/2021



Lane Group	EBL	EBT	WBT	NBL	NBT	SBL	SBT
Lane Configurations		↕↕	↕↔	↔	↔		↕↔
Traffic Volume (vph)	146	254	161	3	12	23	0
Future Volume (vph)	146	254	161	3	12	23	0
Turn Type	Perm	NA	NA	Perm	NA	Perm	NA
Protected Phases		4	8		2		6
Permitted Phases	4			2		6	
Detector Phase	4	4	8	2	2	6	6
Switch Phase							
Minimum Initial (s)	12.0	12.0	12.0	7.0	7.0	7.0	7.0
Minimum Split (s)	24.2	24.2	24.2	24.2	24.2	24.2	24.2
Total Split (s)	56.0	56.0	56.0	39.0	39.0	39.0	39.0
Total Split (%)	58.9%	58.9%	58.9%	41.1%	41.1%	41.1%	41.1%
Yellow Time (s)	4.0	4.0	4.0	4.0	4.0	4.0	4.0
All-Red Time (s)	2.2	2.2	2.2	2.2	2.2	2.2	2.2
Lost Time Adjust (s)		0.0	0.0	0.0	0.0		0.0
Total Lost Time (s)		6.2	6.2	6.2	6.2		6.2
Lead/Lag							
Lead-Lag Optimize?							
Recall Mode	None	None	None	Max	Max	Max	Max

### Intersection Summary

Cycle Length: 95  
 Actuated Cycle Length: 58.2  
 Natural Cycle: 50  
 Control Type: Semi Act-Uncoord

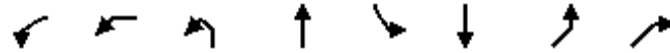
Splits and Phases: 3: Salzedo St. & University Dr.





Signal Timing  
6: University Drive & SR 953 & University Dr.

09/20/2021

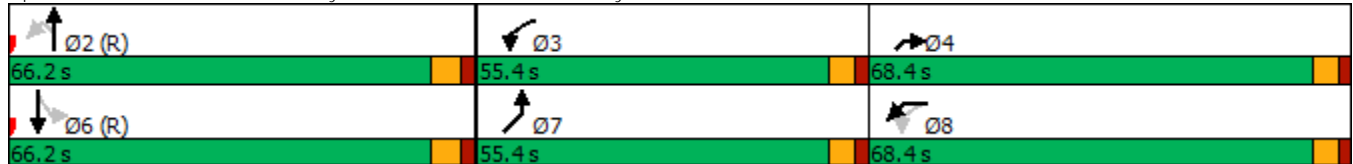


Lane Group	WBL2	WBL	NBL	NBT	SBL	SBT	NEL	NER
Lane Configurations	↖	↖	↖	↑↑	↖	↑↑	↖	↖↗
Traffic Volume (vph)	71	134	18	954	23	952	315	299
Future Volume (vph)	71	134	18	954	23	952	315	299
Turn Type	pm+pt	Prot	Perm	NA	Perm	NA	Prot	Prot
Protected Phases	3	8		2		6	7	4
Permitted Phases	8		2		6			
Detector Phase	3	8	2	2	6	6	7	4
Switch Phase								
Minimum Initial (s)	5.0	5.0	7.0	7.0	7.0	7.0	5.0	5.0
Minimum Split (s)	10.7	35.7	36.6	36.6	36.6	36.6	10.7	35.7
Total Split (s)	55.4	68.4	66.2	66.2	66.2	66.2	55.4	68.4
Total Split (%)	29.2%	36.0%	34.8%	34.8%	34.8%	34.8%	29.2%	36.0%
Yellow Time (s)	3.7	3.7	4.4	4.4	4.4	4.4	3.7	3.7
All-Red Time (s)	2.0	2.0	2.2	2.2	2.2	2.2	2.0	2.0
Lost Time Adjust (s)	0.0	0.0	0.0	0.0	0.0	0.0	0.0	0.0
Total Lost Time (s)	5.7	5.7	6.6	6.6	6.6	6.6	5.7	5.7
Lead/Lag	Lead	Lag					Lead	Lag
Lead-Lag Optimize?	Yes	Yes					Yes	Yes
Recall Mode	Max	Max	Max	Max	Max	Max	Max	Max

Intersection Summary

Cycle Length: 190  
 Actuated Cycle Length: 190  
 Offset: 0 (0%), Referenced to phase 2:NBTL and 6:SBTL, Start of Green  
 Natural Cycle: 95  
 Control Type: Pretimed

Splits and Phases: 6: University Drive & SR 953 & University Dr.



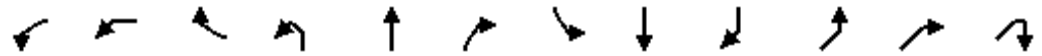
SC 1 AM

3: Salzedo St. & University Dr.

09/22/2021



Movement	EBL	EBT	EBR	WBL	WBT	WBR	NBL	NBT	NBR	SBL	SBT	SBR
Lane Configurations		↕↕			↕↕		↕	↕			↕↕	
Traffic Volume (veh/h)	146	254	0	0	161	8	3	12	15	23	0	69
Future Volume (veh/h)	146	254	0	0	161	8	3	12	15	23	0	69
Initial Q (Qb), veh	0	0	0	0	0	0	0	0	0	0	0	0
Ped-Bike Adj(A_pbT)	0.99		1.00	1.00		0.99	1.00		1.00	1.00		1.00
Parking Bus, Adj	1.00	1.00	1.00	1.00	1.00	1.00	1.00	1.00	1.00	1.00	1.00	1.00
Work Zone On Approach		No			No			No			No	
Adj Sat Flow, veh/h/ln	1885	1885	0	0	1885	1885	1885	1885	1885	1885	1885	1885
Adj Flow Rate, veh/h	146	254	0	0	161	8	3	12	15	23	0	69
Peak Hour Factor	1.00	1.00	1.00	1.00	1.00	1.00	1.00	1.00	1.00	1.00	1.00	1.00
Percent Heavy Veh, %	1	1	0	0	1	1	1	1	1	1	1	1
Cap, veh/h	280	454	0	0	770	38	891	429	537	255	42	660
Arrive On Green	0.22	0.22	0.00	0.00	0.22	0.22	0.56	0.56	0.56	0.56	0.00	0.56
Sat Flow, veh/h	787	2132	0	0	3565	171	1339	760	950	315	75	1169
Grp Volume(v), veh/h	209	191	0	0	83	86	3	0	27	92	0	0
Grp Sat Flow(s),veh/h/ln	1203	1630	0	0	1791	1852	1339	0	1711	1558	0	0
Q Serve(g_s), s	7.8	6.0	0.0	0.0	2.2	2.2	0.0	0.0	0.4	0.0	0.0	0.0
Cycle Q Clear(g_c), s	10.0	6.0	0.0	0.0	2.2	2.2	0.0	0.0	0.4	1.5	0.0	0.0
Prop In Lane	0.70		0.00	0.00		0.09	1.00		0.56	0.25		0.75
Lane Grp Cap(c), veh/h	372	362	0	0	397	411	891	0	966	957	0	0
V/C Ratio(X)	0.56	0.53	0.00	0.00	0.21	0.21	0.00	0.00	0.03	0.10	0.00	0.00
Avail Cap(c_a), veh/h	1236	1397	0	0	1535	1587	891	0	966	957	0	0
HCM Platoon Ratio	1.00	1.00	1.00	1.00	1.00	1.00	1.00	1.00	1.00	1.00	1.00	1.00
Upstream Filter(I)	1.00	1.00	0.00	0.00	1.00	1.00	1.00	0.00	1.00	1.00	0.00	0.00
Uniform Delay (d), s/veh	22.0	19.9	0.0	0.0	18.4	18.4	5.5	0.0	5.6	5.8	0.0	0.0
Incr Delay (d2), s/veh	0.5	0.4	0.0	0.0	0.4	0.4	0.0	0.0	0.1	0.2	0.0	0.0
Initial Q Delay(d3),s/veh	0.0	0.0	0.0	0.0	0.0	0.0	0.0	0.0	0.0	0.0	0.0	0.0
%ile BackOfQ(95%),veh/ln	4.6	3.8	0.0	0.0	1.6	1.7	0.0	0.0	0.2	0.8	0.0	0.0
Unsig. Movement Delay, s/veh												
LnGrp Delay(d),s/veh	22.5	20.4	0.0	0.0	18.8	18.8	5.5	0.0	5.6	6.0	0.0	0.0
LnGrp LOS	C	C	A	A	B	B	A	A	A	A	A	A
Approach Vol, veh/h		400			169			30			92	
Approach Delay, s/veh		21.5			18.8			5.6			6.0	
Approach LOS		C			B			A			A	
Timer - Assigned Phs		2		4		6		8				
Phs Duration (G+Y+Rc), s		39.0		19.1		39.0		19.1				
Change Period (Y+Rc), s		* 6.2		* 6.2		* 6.2		* 6.2				
Max Green Setting (Gmax), s		* 33		* 50		* 33		* 50				
Max Q Clear Time (g_c+I1), s		2.4		12.0		3.5		4.2				
Green Ext Time (p_c), s		0.1		0.9		0.2		1.5				
<b>Intersection Summary</b>												
HCM 6th Ctrl Delay				18.1								
HCM 6th LOS				B								
<b>Notes</b>												
* HCM 6th computational engine requires equal clearance times for the phases crossing the barrier.												



Movement	WBL2	WBL	WBR	NBL	NBT	NBR	SBL	SBT	SBR	NEL	NER	NER2
Lane Configurations												
Traffic Volume (veh/h)	71	134	18	18	954	67	23	952	180	315	299	12
Future Volume (veh/h)	71	134	18	18	954	67	23	952	180	315	299	12
Initial Q (Qb), veh	0	0	0	0	0	0	0	0	0	0	0	0
Ped-Bike Adj(A_pbT)	0.99	0.99	0.99	1.00		1.00	1.00		1.00	1.00	1.00	1.00
Parking Bus, Adj	1.00	1.00	1.00	1.00	1.00	1.00	1.00	1.00	1.00	1.00	1.00	1.00
Work Zone On Approach		No			No			No		No		
Adj Sat Flow, veh/h/ln	1870	1870	1870	1870	1870	1870	1870	1870	1870	1870	1870	1870
Adj Flow Rate, veh/h	71	71	18	18	954	67	23	952	180	315	0	0
Peak Hour Factor	1.00	1.00	1.00	1.00	1.00	1.00	1.00	1.00	1.00	1.00	1.00	1.00
Percent Heavy Veh, %	2	2	2	2	2	2	2	2	2	2	2	2
Cap, veh/h	967	967	71	38	1056	74	61	935	177	466		
Arrive On Green	0.26	0.26	0.33	0.31	0.31	0.31	0.31	0.31	0.31	0.26	0.00	0.00
Sat Flow, veh/h	1781	1781	217	497	3368	237	552	2981	563	1781	0	0
Grp Volume(v), veh/h	71	71	152	18	503	518	23	567	565	315	0	0
Grp Sat Flow(s),veh/h/ln	1781	1781	1829	497	1777	1827	552	1777	1767	1781	0	0
Q Serve(g_s), s	3.2	3.2	11.5	0.0	51.5	51.5	7.9	59.6	59.6	30.1	0.0	0.0
Cycle Q Clear(g_c), s	3.2	3.2	11.5	59.6	51.5	51.5	59.5	59.6	59.6	30.1	0.0	0.0
Prop In Lane	1.00	1.00	0.12	1.00		0.13	1.00		0.32	1.00	0.00	0.00
Lane Grp Cap(c), veh/h	967	967	604	38	557	573	61	557	554	466		
V/C Ratio(X)	0.07	0.07	0.25	0.47	0.90	0.90	0.38	1.02	1.02	0.68		
Avail Cap(c_a), veh/h	967	967	604	38	557	573	61	557	554	466		
HCM Platoon Ratio	1.00	1.00	1.00	1.00	1.00	1.00	1.00	1.00	1.00	1.00	1.00	1.00
Upstream Filter(I)	1.00	1.00	1.00	1.00	1.00	1.00	1.00	1.00	1.00	1.00	0.00	0.00
Uniform Delay (d), s/veh	16.5	16.5	46.5	95.0	62.4	62.4	90.9	65.2	65.2	62.9	0.0	0.0
Incr Delay (d2), s/veh	0.1	0.1	1.0	37.1	20.5	20.1	16.6	42.6	43.1	7.7	0.0	0.0
Initial Q Delay(d3),s/veh	0.0	0.0	0.0	0.0	0.0	0.0	0.0	0.0	0.0	0.0	0.0	0.0
%ile BackOfQ(95%),veh/ln	2.5	2.5	9.4	2.3	35.0	35.8	2.6	43.7	43.6	21.1	0.0	0.0
Unsig. Movement Delay, s/veh												
LnGrp Delay(d),s/veh	16.7	16.7	47.5	132.1	82.9	82.5	107.5	107.8	108.3	70.6	0.0	0.0
LnGrp LOS	B	B	D	F	F	F	F	F	F	E		
Approach Vol, veh/h	223	223			1039			1155		315	A	A
Approach Delay, s/veh	37.7	37.7			83.6			108.1		70.6		
Approach LOS	D	D			F			F		E		
Timer - Assigned Phs		2	3	4		6	7	8				
Phs Duration (G+Y+Rc), s		66.2	55.4	68.4		66.2	55.4	68.4				
Change Period (Y+Rc), s		* 6.6	* 5.7	* 5.7		* 6.6	* 5.7	* 5.7				
Max Green Setting (Gmax), s		* 60	* 50	* 63		* 60	* 50	* 63				
Max Q Clear Time (g_c+I1), s		61.6	5.2	0.0		61.6	32.1	13.5				
Green Ext Time (p_c), s		0.0	0.1	0.0		0.0	0.4	0.2				

Intersection Summary

HCM 6th Ctrl Delay	88.7
HCM 6th LOS	F

Notes

\* HCM 6th computational engine requires equal clearance times for the phases crossing the barrier.  
 Unsignalized Delay for [NER2] is excluded from calculations of the approach delay and intersection delay.

SC 1 AM  
12: Salzedo St. & Catalonia Ave.

09/22/2021

Intersection	
Intersection Delay, s/veh	8.9
Intersection LOS	A

Movement	EBL	EBT	EBR	WBL	WBT	WBR	NBL	NBT	NBR	SBL	SBT	SBR
Lane Configurations		↕			↕			↕			↕	
Traffic Vol, veh/h	30	106	7	7	15	29	5	194	21	13	110	13
Future Vol, veh/h	30	106	7	7	15	29	5	194	21	13	110	13
Peak Hour Factor	1.00	1.00	1.00	1.00	1.00	1.00	1.00	1.00	1.00	1.00	1.00	1.00
Heavy Vehicles, %	2	2	2	2	2	2	2	2	2	2	2	2
Mvmt Flow	30	106	7	7	15	29	5	194	21	13	110	13
Number of Lanes	0	1	0	0	1	0	0	1	0	0	1	0

Approach	EB	WB	NB	SB
Opposing Approach	WB	EB	SB	NB
Opposing Lanes	1	1	1	1
Conflicting Approach Left	SB	NB	EB	WB
Conflicting Lanes Left	1	1	1	1
Conflicting Approach Right	NB	SB	WB	EB
Conflicting Lanes Right	1	1	1	1
HCM Control Delay	9	8	9.3	8.6
HCM LOS	A	A	A	A

Lane	NBLn1	EBLn1	WBLn1	SBLn1
Vol Left, %	2%	21%	14%	10%
Vol Thru, %	88%	74%	29%	81%
Vol Right, %	10%	5%	57%	10%
Sign Control	Stop	Stop	Stop	Stop
Traffic Vol by Lane	220	143	51	136
LT Vol	5	30	7	13
Through Vol	194	106	15	110
RT Vol	21	7	29	13
Lane Flow Rate	220	143	51	136
Geometry Grp	1	1	1	1
Degree of Util (X)	0.276	0.192	0.066	0.174
Departure Headway (Hd)	4.512	4.827	4.626	4.619
Convergence, Y/N	Yes	Yes	Yes	Yes
Cap	796	742	771	775
Service Time	2.545	2.867	2.673	2.657
HCM Lane V/C Ratio	0.276	0.193	0.066	0.175
HCM Control Delay	9.3	9	8	8.6
HCM Lane LOS	A	A	A	A
HCM 95th-tile Q	1.1	0.7	0.2	0.6

Intersection												
Int Delay, s/veh	2.9											
Movement	EBL	EBT	EBR	WBL	WBT	WBR	NBL	NBT	NBR	SBL	SBT	SBR
Lane Configurations		↕			↕			↕			↕	
Traffic Vol, veh/h	11	33	5	4	18	21	5	171	12	14	94	6
Future Vol, veh/h	11	33	5	4	18	21	5	171	12	14	94	6
Conflicting Peds, #/hr	2	0	1	1	0	2	2	0	8	8	0	2
Sign Control	Stop	Stop	Stop	Stop	Stop	Stop	Free	Free	Free	Free	Free	Free
RT Channelized	-	-	None	-	-	None	-	-	None	-	-	None
Storage Length	-	-	-	-	-	-	-	-	-	-	-	-
Veh in Median Storage, #	-	0	-	-	0	-	-	0	-	-	0	-
Grade, %	-	0	-	-	0	-	-	0	-	-	0	-
Peak Hour Factor	100	100	100	100	100	100	100	100	100	100	100	100
Heavy Vehicles, %	2	2	2	2	2	2	2	2	2	2	2	2
Mvmt Flow	11	33	5	4	18	21	5	171	12	14	94	6

Major/Minor	Minor2		Minor1		Major1		Major2					
Conflicting Flow All	336	328	100	340	325	187	102	0	0	191	0	0
Stage 1	127	127	-	195	195	-	-	-	-	-	-	-
Stage 2	209	201	-	145	130	-	-	-	-	-	-	-
Critical Hdwy	7.12	6.52	6.22	7.12	6.52	6.22	4.12	-	-	4.12	-	-
Critical Hdwy Stg 1	6.12	5.52	-	6.12	5.52	-	-	-	-	-	-	-
Critical Hdwy Stg 2	6.12	5.52	-	6.12	5.52	-	-	-	-	-	-	-
Follow-up Hdwy	3.518	4.018	3.318	3.518	4.018	3.318	2.218	-	-	2.218	-	-
Pot Cap-1 Maneuver	618	591	956	614	593	855	1490	-	-	1383	-	-
Stage 1	877	791	-	807	739	-	-	-	-	-	-	-
Stage 2	793	735	-	858	789	-	-	-	-	-	-	-
Platoon blocked, %								-	-	-	-	-
Mov Cap-1 Maneuver	580	576	953	572	578	847	1487	-	-	1372	-	-
Mov Cap-2 Maneuver	580	576	-	572	578	-	-	-	-	-	-	-
Stage 1	872	781	-	797	730	-	-	-	-	-	-	-
Stage 2	750	726	-	808	779	-	-	-	-	-	-	-

Approach	EB		WB		NB		SB	
HCM Control Delay, s	11.5		10.6		0.2		0.9	
HCM LOS	B		B					

Minor Lane/Major Mvmt	NBL	NBT	NBR	EBLn1	WBLn1	SBL	SBT	SBR
Capacity (veh/h)	1487	-	-	601	683	1372	-	-
HCM Lane V/C Ratio	0.003	-	-	0.082	0.063	0.01	-	-
HCM Control Delay (s)	7.4	0	-	11.5	10.6	7.7	0	-
HCM Lane LOS	A	A	-	B	B	A	A	-
HCM 95th %tile Q(veh)	0	-	-	0.3	0.2	0	-	-

Intersection						
Int Delay, s/veh	1					
Movement	WBL	WBR	NBT	NBR	SBL	SBT
Lane Configurations	↔		↑↓		↔	↑↑
Traffic Vol, veh/h	5	25	1312	23	106	1293
Future Vol, veh/h	5	25	1312	23	106	1293
Conflicting Peds, #/hr	0	0	0	0	0	0
Sign Control	Stop	Stop	Free	Free	Free	Free
RT Channelized	-	None	-	None	-	None
Storage Length	0	-	-	-	50	-
Veh in Median Storage, #	0	-	0	-	-	0
Grade, %	0	-	0	-	-	0
Peak Hour Factor	100	100	100	100	100	100
Heavy Vehicles, %	3	3	3	3	3	3
Mvmt Flow	5	25	1312	23	106	1293

Major/Minor	Minor1	Major1	Major2		
Conflicting Flow All	2183	668	0	0	1335
Stage 1	1324	-	-	-	-
Stage 2	859	-	-	-	-
Critical Hdwy	6.86	6.96	-	-	4.16
Critical Hdwy Stg 1	5.86	-	-	-	-
Critical Hdwy Stg 2	5.86	-	-	-	-
Follow-up Hdwy	3.53	3.33	-	-	2.23
Pot Cap-1 Maneuver	39	398	-	-	507
Stage 1	211	-	-	-	-
Stage 2	373	-	-	-	-
Platoon blocked, %			-	-	-
Mov Cap-1 Maneuver	31	398	-	-	507
Mov Cap-2 Maneuver	31	-	-	-	-
Stage 1	211	-	-	-	-
Stage 2	295	-	-	-	-

Approach	WB	NB	SB
HCM Control Delay, s	39.5	0	1.1
HCM LOS	E		

Minor Lane/Major Mvmt	NBT	NBRWBLn1	SBL	SBT
Capacity (veh/h)	-	-	134	507
HCM Lane V/C Ratio	-	-	0.224	0.209
HCM Control Delay (s)	-	-	39.5	14
HCM Lane LOS	-	-	E	B
HCM 95th %tile Q(veh)	-	-	0.8	0.8

SC 1 AM  
16: Malaga Ave. & SR 953

09/22/2021

Intersection						
Int Delay, s/veh	0.8					
Movement	WBL	WBR	NBT	NBR	SBL	SBT
Lane Configurations						
Traffic Vol, veh/h	6	15	1243	6	34	1051
Future Vol, veh/h	6	15	1243	6	34	1051
Conflicting Peds, #/hr	0	0	0	0	0	0
Sign Control	Stop	Stop	Free	Free	Free	Free
RT Channelized	-	None	-	None	-	None
Storage Length	0	-	-	-	-	-
Veh in Median Storage, #	0	-	0	-	-	0
Grade, %	0	-	0	-	-	0
Peak Hour Factor	100	100	100	100	100	100
Heavy Vehicles, %	2	2	2	2	2	2
Mvmt Flow	6	15	1243	6	34	1051

Major/Minor	Minor1	Major1	Major2		
Conflicting Flow All	1840	625	0	0	1249
Stage 1	1246	-	-	-	-
Stage 2	594	-	-	-	-
Critical Hdwy	6.84	6.94	-	-	4.14
Critical Hdwy Stg 1	5.84	-	-	-	-
Critical Hdwy Stg 2	5.84	-	-	-	-
Follow-up Hdwy	3.52	3.32	-	-	2.22
Pot Cap-1 Maneuver	67	428	-	-	553
Stage 1	234	-	-	-	-
Stage 2	514	-	-	-	-
Platoon blocked, %			-	-	-
Mov Cap-1 Maneuver	57	428	-	-	553
Mov Cap-2 Maneuver	57	-	-	-	-
Stage 1	234	-	-	-	-
Stage 2	438	-	-	-	-

Approach	WB	NB	SB
HCM Control Delay, s	32.9	0	1.1
HCM LOS	D		

Minor Lane/Major Mvmt	NBT	NBRWBLn1	SBL	SBT
Capacity (veh/h)	-	-	150	553
HCM Lane V/C Ratio	-	-	0.14	0.061
HCM Control Delay (s)	-	-	32.9	11.9
HCM Lane LOS	-	-	D	B
HCM 95th %tile Q(veh)	-	-	0.5	0.2

SC 1 AM  
17: SR 953 & Catalonia Avenue

09/22/2021

Intersection						
Int Delay, s/veh	1					
Movement	EBL	EBR	NBL	NBT	SBT	SBR
Lane Configurations						
Traffic Vol, veh/h	16	30	24	1312	1293	5
Future Vol, veh/h	16	30	24	1312	1293	5
Conflicting Peds, #/hr	0	0	0	0	0	0
Sign Control	Stop	Stop	Free	Free	Free	Free
RT Channelized	-	None	-	None	-	None
Storage Length	0	-	50	-	-	-
Veh in Median Storage, #	0	-	-	0	0	-
Grade, %	0	-	-	0	0	-
Peak Hour Factor	100	100	100	100	100	100
Heavy Vehicles, %	2	2	2	2	2	2
Mvmt Flow	16	30	24	1312	1293	5

Major/Minor	Minor2	Major1	Major2			
Conflicting Flow All	2000	649	1298	0	-	0
Stage 1	1296	-	-	-	-	-
Stage 2	704	-	-	-	-	-
Critical Hdwy	6.84	6.94	4.14	-	-	-
Critical Hdwy Stg 1	5.84	-	-	-	-	-
Critical Hdwy Stg 2	5.84	-	-	-	-	-
Follow-up Hdwy	3.52	3.32	2.22	-	-	-
Pot Cap-1 Maneuver	52	412	530	-	-	-
Stage 1	220	-	-	-	-	-
Stage 2	452	-	-	-	-	-
Platoon blocked, %				-	-	-
Mov Cap-1 Maneuver	50	412	530	-	-	-
Mov Cap-2 Maneuver	50	-	-	-	-	-
Stage 1	210	-	-	-	-	-
Stage 2	452	-	-	-	-	-

Approach	EB	NB	SB
HCM Control Delay, s	54.4	0.2	0
HCM LOS	F		

Minor Lane/Major Mvmt	NBL	NBT	EBLn1	SBT	SBR
Capacity (veh/h)	530	-	117	-	-
HCM Lane V/C Ratio	0.045	-	0.393	-	-
HCM Control Delay (s)	12.1	-	54.4	-	-
HCM Lane LOS	B	-	F	-	-
HCM 95th %tile Q(veh)	0.1	-	1.6	-	-



SC 1 AM  
18: SR 953 & Malaga Avenue

09/22/2021

Intersection						
Int Delay, s/veh	0.4					
Movement	EBL	EBR	NBL	NBT	SBT	SBR
Lane Configurations	↔		↔	↑↑	↑↑	
Traffic Vol, veh/h	10	14	17	1243	1051	12
Future Vol, veh/h	10	14	17	1243	1051	12
Conflicting Peds, #/hr	0	4	1	0	0	1
Sign Control	Stop	Stop	Free	Free	Free	Free
RT Channelized	-	None	-	None	-	None
Storage Length	0	-	50	-	-	-
Veh in Median Storage, #	0	-	-	0	0	-
Grade, %	0	-	-	0	0	-
Peak Hour Factor	100	100	100	100	100	100
Heavy Vehicles, %	2	2	2	2	2	2
Mvmt Flow	10	14	17	1243	1051	12

Major/Minor	Minor2	Major1	Major2			
Conflicting Flow All	1714	537	1064	0	-	0
Stage 1	1058	-	-	-	-	-
Stage 2	656	-	-	-	-	-
Critical Hdwy	6.84	6.94	4.14	-	-	-
Critical Hdwy Stg 1	5.84	-	-	-	-	-
Critical Hdwy Stg 2	5.84	-	-	-	-	-
Follow-up Hdwy	3.52	3.32	2.22	-	-	-
Pot Cap-1 Maneuver	81	488	651	-	-	-
Stage 1	295	-	-	-	-	-
Stage 2	478	-	-	-	-	-
Platoon blocked, %				-	-	-
Mov Cap-1 Maneuver	79	486	650	-	-	-
Mov Cap-2 Maneuver	79	-	-	-	-	-
Stage 1	287	-	-	-	-	-
Stage 2	478	-	-	-	-	-

Approach	EB	NB	SB
HCM Control Delay, s	32.6	0.1	0
HCM LOS	D		

Minor Lane/Major Mvmt	NBL	NBT	EBLn1	SBT	SBR
Capacity (veh/h)	650	-	154	-	-
HCM Lane V/C Ratio	0.026	-	0.156	-	-
HCM Control Delay (s)	10.7	-	32.6	-	-
HCM Lane LOS	B	-	D	-	-
HCM 95th %tile Q(veh)	0.1	-	0.5	-	-

## Scenario 1 - PM

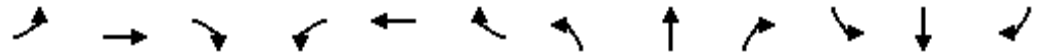
SC 1 PM

3: Salzedo St. & University Dr.

09/22/2021



Movement	EBL	EBT	EBR	WBL	WBT	WBR	NBL	NBT	NBR	SBL	SBT	SBR
Lane Configurations		↕↕			↕↕		↕	↕			↕↕	
Traffic Volume (veh/h)	36	122	0	0	416	8	4	8	9	11	0	218
Future Volume (veh/h)	36	122	0	0	416	8	4	8	9	11	0	218
Initial Q (Qb), veh	0	0	0	0	0	0	0	0	0	0	0	0
Ped-Bike Adj(A_pbT)	0.99		1.00	1.00		0.97	1.00		1.00	1.00		1.00
Parking Bus, Adj	1.00	1.00	1.00	1.00	1.00	1.00	1.00	1.00	1.00	1.00	1.00	1.00
Work Zone On Approach		No			No			No			No	
Adj Sat Flow, veh/h/ln	1885	1885	0	0	1885	1885	1885	1885	1885	1885	1885	1885
Adj Flow Rate, veh/h	36	122	0	0	416	8	4	8	9	11	0	218
Peak Hour Factor	1.00	1.00	1.00	1.00	1.00	1.00	1.00	1.00	1.00	1.00	1.00	1.00
Percent Heavy Veh, %	1	1	0	0	1	1	1	1	1	1	1	1
Cap, veh/h	86	319	0	0	578	11	924	586	660	66	24	1099
Arrive On Green	0.16	0.16	0.00	0.00	0.16	0.16	0.73	0.73	0.73	0.73	0.00	0.73
Sat Flow, veh/h	214	2066	0	0	3686	69	1170	808	909	43	33	1515
Grp Volume(v), veh/h	65	93	0	0	207	217	4	0	17	229	0	0
Grp Sat Flow(s),veh/h/ln	565	1630	0	0	1791	1870	1170	0	1718	1592	0	0
Q Serve(g_s), s	3.2	5.5	0.0	0.0	12.0	12.0	0.0	0.0	0.3	0.0	0.0	0.0
Cycle Q Clear(g_c), s	15.1	5.5	0.0	0.0	12.0	12.0	0.1	0.0	0.3	5.0	0.0	0.0
Prop In Lane	0.55		0.00	0.00		0.04	1.00		0.53	0.05		0.95
Lane Grp Cap(c), veh/h	142	262	0	0	288	301	924	0	1246	1189	0	0
V/C Ratio(X)	0.46	0.35	0.00	0.00	0.72	0.72	0.00	0.00	0.01	0.19	0.00	0.00
Avail Cap(c_a), veh/h	1064	1481	0	0	1628	1700	924	0	1246	1189	0	0
HCM Platoon Ratio	1.00	1.00	1.00	1.00	1.00	1.00	1.00	1.00	1.00	1.00	1.00	1.00
Upstream Filter(I)	1.00	1.00	0.00	0.00	1.00	1.00	1.00	0.00	1.00	1.00	0.00	0.00
Uniform Delay (d), s/veh	45.1	40.7	0.0	0.0	43.4	43.4	4.1	0.0	4.2	4.8	0.0	0.0
Incr Delay (d2), s/veh	0.9	0.3	0.0	0.0	1.3	1.2	0.0	0.0	0.0	0.4	0.0	0.0
Initial Q Delay(d3),s/veh	0.0	0.0	0.0	0.0	0.0	0.0	0.0	0.0	0.0	0.0	0.0	0.0
%ile BackOfQ(95%),veh/ln	3.2	4.0	0.0	0.0	9.2	9.5	0.0	0.0	0.2	2.8	0.0	0.0
Unsig. Movement Delay, s/veh												
LnGrp Delay(d),s/veh	45.9	41.0	0.0	0.0	44.6	44.6	4.1	0.0	4.2	5.2	0.0	0.0
LnGrp LOS	D	D	A	A	D	D	A	A	A	A	A	A
Approach Vol, veh/h		158			424			21			229	
Approach Delay, s/veh		43.0			44.6			4.2			5.2	
Approach LOS		D			D			A			A	
Timer - Assigned Phs		2		4		6		8				
Phs Duration (G+Y+Rc), s		85.2		23.7		85.2		23.7				
Change Period (Y+Rc), s		* 6.2		* 6.2		* 6.2		* 6.2				
Max Green Setting (Gmax), s		* 79		* 99		* 79		* 99				
Max Q Clear Time (g_c+I1), s		2.3		17.1		7.0		14.0				
Green Ext Time (p_c), s		0.1		0.4		2.5		0.9				
<b>Intersection Summary</b>												
HCM 6th Ctrl Delay				32.4								
HCM 6th LOS				C								
<b>Notes</b>												
* HCM 6th computational engine requires equal clearance times for the phases crossing the barrier.												



Movement	EBL	EBT	EBR	WBL	WBT	WBR	NBL	NBT	NBR	SBL	SBT	SBR
Lane Configurations	↖	↗		↖	↗		↖	↗		↖	↗	
Traffic Volume (veh/h)	136	115	28	236	384	8	64	934	37	25	966	353
Future Volume (veh/h)	136	115	28	236	384	8	64	934	37	25	966	353
Initial Q (Qb), veh	0	0	0	0	0	0	0	0	0	0	0	0
Ped-Bike Adj(A_pbT)	1.00		1.00	1.00		1.00	1.00		1.00	1.00		1.00
Parking Bus, Adj	1.00	1.00	1.00	1.00	1.00	1.00	1.00	1.00	1.00	1.00	1.00	1.00
Work Zone On Approach		No			No			No			No	
Adj Sat Flow, veh/h/ln	1870	1870	1870	1870	1870	1870	1870	1870	1870	1870	1870	1870
Adj Flow Rate, veh/h	136	115	0	236	384	8	64	934	37	25	966	353
Peak Hour Factor	1.00	1.00	1.00	1.00	1.00	1.00	1.00	1.00	1.00	1.00	1.00	1.00
Percent Heavy Veh, %	2	2	2	2	2	2	2	2	2	2	2	2
Cap, veh/h	466	1173		896	602	13	38	1093	43	74	801	290
Arrive On Green	0.26	0.33	0.00	0.26	0.33	0.33	0.31	0.31	0.31	0.31	0.31	0.31
Sat Flow, veh/h	1781	3647	0	1781	1825	38	416	3484	138	579	2552	925
Grp Volume(v), veh/h	136	115	0	236	0	392	64	476	495	25	670	649
Grp Sat Flow(s),veh/h/ln	1781	1777	0	1781	0	1863	416	1777	1845	579	1777	1700
Q Serve(g_s), s	11.6	4.3	0.0	11.9	0.0	33.9	0.0	47.8	47.8	8.0	59.6	59.6
Cycle Q Clear(g_c), s	11.6	4.3	0.0	11.9	0.0	33.9	59.6	47.8	47.8	55.8	59.6	59.6
Prop In Lane	1.00		0.00	1.00		0.02	1.00		0.07	1.00		0.54
Lane Grp Cap(c), veh/h	466	1173		896	0	615	38	557	579	74	557	533
V/C Ratio(X)	0.29	0.10		0.26	0.00	0.64	1.69	0.85	0.85	0.34	1.20	1.22
Avail Cap(c_a), veh/h	466	1173		896	0	615	38	557	579	74	557	533
HCM Platoon Ratio	1.00	1.00	1.00	1.00	1.00	1.00	1.00	1.00	1.00	1.00	1.00	1.00
Upstream Filter(I)	1.00	1.00	0.00	1.00	0.00	1.00	1.00	1.00	1.00	1.00	1.00	1.00
Uniform Delay (d), s/veh	56.1	44.1	0.0	18.3	0.0	54.0	95.0	61.1	61.1	87.3	65.2	65.2
Incr Delay (d2), s/veh	1.6	0.2	0.0	0.7	0.0	5.0	400.2	15.4	14.9	11.9	107.4	113.6
Initial Q Delay(d3),s/veh	0.0	0.0	0.0	0.0	0.0	0.0	0.0	0.0	0.0	0.0	0.0	0.0
%ile BackOfQ(95%),veh/ln	9.4	3.5	0.0	9.0	0.0	23.7	11.0	32.1	33.1	2.6	61.2	60.4
Unsig. Movement Delay, s/veh												
LnGrp Delay(d),s/veh	57.7	44.2	0.0	19.0	0.0	59.0	495.2	76.5	76.0	99.2	172.6	178.8
LnGrp LOS	E	D		B	A	E	F	E	E	F	F	F
Approach Vol, veh/h		251	A		628			1035			1344	
Approach Delay, s/veh		51.5			44.0			102.2			174.2	
Approach LOS		D			D			F			F	
Timer - Assigned Phs		2	3	4		6	7	8				
Phs Duration (G+Y+Rc), s		66.2	55.4	68.4		66.2	55.4	68.4				
Change Period (Y+Rc), s		* 6.6	* 5.7	* 5.7		* 6.6	* 5.7	* 5.7				
Max Green Setting (Gmax), s		* 60	* 50	* 63		* 60	* 50	* 63				
Max Q Clear Time (g_c+I1), s		61.6	13.9	6.3		61.6	13.6	35.9				
Green Ext Time (p_c), s		0.0	0.3	0.6		0.0	0.2	1.6				

Intersection Summary

HCM 6th Ctrl Delay	116.8
HCM 6th LOS	F

Notes

\* HCM 6th computational engine requires equal clearance times for the phases crossing the barrier.  
 Unsignalized Delay for [EBR] is excluded from calculations of the approach delay and intersection delay.

Intersection	
Intersection Delay, s/veh	9
Intersection LOS	A

Movement	EBL	EBT	EBR	WBL	WBT	WBR	NBL	NBT	NBR	SBL	SBT	SBR
Lane Configurations		↕			↕			↕			↕	
Traffic Vol, veh/h	12	45	8	16	76	23	4	63	4	18	215	36
Future Vol, veh/h	12	45	8	16	76	23	4	63	4	18	215	36
Peak Hour Factor	1.00	1.00	1.00	1.00	1.00	1.00	1.00	1.00	1.00	1.00	1.00	1.00
Heavy Vehicles, %	3	3	3	3	3	3	3	3	3	3	3	3
Mvmt Flow	12	45	8	16	76	23	4	63	4	18	215	36
Number of Lanes	0	1	0	0	1	0	0	1	0	0	1	0

Approach	EB	WB	NB	SB
Opposing Approach	WB	EB	SB	NB
Opposing Lanes	1	1	1	1
Conflicting Approach Left	SB	NB	EB	WB
Conflicting Lanes Left	1	1	1	1
Conflicting Approach Right	NB	SB	WB	EB
Conflicting Lanes Right	1	1	1	1
HCM Control Delay	8.3	8.6	8.2	9.6
HCM LOS	A	A	A	A

Lane	NBLn1	EBLn1	WBLn1	SBLn1
Vol Left, %	6%	18%	14%	7%
Vol Thru, %	89%	69%	66%	80%
Vol Right, %	6%	12%	20%	13%
Sign Control	Stop	Stop	Stop	Stop
Traffic Vol by Lane	71	65	115	269
LT Vol	4	12	16	18
Through Vol	63	45	76	215
RT Vol	4	8	23	36
Lane Flow Rate	71	65	115	269
Geometry Grp	1	1	1	1
Degree of Util (X)	0.092	0.087	0.151	0.329
Departure Headway (Hd)	4.665	4.84	4.721	4.404
Convergence, Y/N	Yes	Yes	Yes	Yes
Cap	768	739	759	818
Service Time	2.698	2.876	2.754	2.429
HCM Lane V/C Ratio	0.092	0.088	0.152	0.329
HCM Control Delay	8.2	8.3	8.6	9.6
HCM Lane LOS	A	A	A	A
HCM 95th-tile Q	0.3	0.3	0.5	1.4

SC 1 PM

3: Salzedo St. & University Dr.

09/22/2021



Movement	EBL	EBT	EBR	WBL	WBT	WBR	NBL	NBT	NBR	SBL	SBT	SBR
Lane Configurations		↕↕			↕↕		↕	↕			↕↕	
Traffic Volume (veh/h)	36	122	0	0	416	8	4	8	9	11	0	218
Future Volume (veh/h)	36	122	0	0	416	8	4	8	9	11	0	218
Initial Q (Qb), veh	0	0	0	0	0	0	0	0	0	0	0	0
Ped-Bike Adj(A_pbT)	0.99		1.00	1.00		0.97	1.00		1.00	1.00		1.00
Parking Bus, Adj	1.00	1.00	1.00	1.00	1.00	1.00	1.00	1.00	1.00	1.00	1.00	1.00
Work Zone On Approach		No			No			No			No	
Adj Sat Flow, veh/h/ln	1885	1885	0	0	1885	1885	1885	1885	1885	1885	1885	1885
Adj Flow Rate, veh/h	36	122	0	0	416	8	4	8	9	11	0	218
Peak Hour Factor	1.00	1.00	1.00	1.00	1.00	1.00	1.00	1.00	1.00	1.00	1.00	1.00
Percent Heavy Veh, %	1	1	0	0	1	1	1	1	1	1	1	1
Cap, veh/h	86	319	0	0	578	11	924	586	660	66	24	1099
Arrive On Green	0.16	0.16	0.00	0.00	0.16	0.16	0.73	0.73	0.73	0.73	0.00	0.73
Sat Flow, veh/h	214	2066	0	0	3686	69	1170	808	909	43	33	1515
Grp Volume(v), veh/h	65	93	0	0	207	217	4	0	17	229	0	0
Grp Sat Flow(s),veh/h/ln	565	1630	0	0	1791	1870	1170	0	1718	1592	0	0
Q Serve(g_s), s	3.2	5.5	0.0	0.0	12.0	12.0	0.0	0.0	0.3	0.0	0.0	0.0
Cycle Q Clear(g_c), s	15.1	5.5	0.0	0.0	12.0	12.0	0.1	0.0	0.3	5.0	0.0	0.0
Prop In Lane	0.55		0.00	0.00		0.04	1.00		0.53	0.05		0.95
Lane Grp Cap(c), veh/h	142	262	0	0	288	301	924	0	1246	1189	0	0
V/C Ratio(X)	0.46	0.35	0.00	0.00	0.72	0.72	0.00	0.00	0.01	0.19	0.00	0.00
Avail Cap(c_a), veh/h	1064	1481	0	0	1628	1700	924	0	1246	1189	0	0
HCM Platoon Ratio	1.00	1.00	1.00	1.00	1.00	1.00	1.00	1.00	1.00	1.00	1.00	1.00
Upstream Filter(I)	1.00	1.00	0.00	0.00	1.00	1.00	1.00	0.00	1.00	1.00	0.00	0.00
Uniform Delay (d), s/veh	45.1	40.7	0.0	0.0	43.4	43.4	4.1	0.0	4.2	4.8	0.0	0.0
Incr Delay (d2), s/veh	0.9	0.3	0.0	0.0	1.3	1.2	0.0	0.0	0.0	0.4	0.0	0.0
Initial Q Delay(d3),s/veh	0.0	0.0	0.0	0.0	0.0	0.0	0.0	0.0	0.0	0.0	0.0	0.0
%ile BackOfQ(95%),veh/ln	3.2	4.0	0.0	0.0	9.2	9.5	0.0	0.0	0.2	2.8	0.0	0.0
Unsig. Movement Delay, s/veh												
LnGrp Delay(d),s/veh	45.9	41.0	0.0	0.0	44.6	44.6	4.1	0.0	4.2	5.2	0.0	0.0
LnGrp LOS	D	D	A	A	D	D	A	A	A	A	A	A
Approach Vol, veh/h		158			424			21			229	
Approach Delay, s/veh		43.0			44.6			4.2			5.2	
Approach LOS		D			D			A			A	
Timer - Assigned Phs		2		4		6		8				
Phs Duration (G+Y+Rc), s		85.2		23.7		85.2		23.7				
Change Period (Y+Rc), s		* 6.2		* 6.2		* 6.2		* 6.2				
Max Green Setting (Gmax), s		* 79		* 99		* 79		* 99				
Max Q Clear Time (g_c+I1), s		2.3		17.1		7.0		14.0				
Green Ext Time (p_c), s		0.1		0.4		2.5		0.9				
<b>Intersection Summary</b>												
HCM 6th Ctrl Delay				32.4								
HCM 6th LOS				C								
<b>Notes</b>												
* HCM 6th computational engine requires equal clearance times for the phases crossing the barrier.												



Movement	EBL	EBT	EBR	WBL	WBT	WBR	NBL	NBT	NBR	SBL	SBT	SBR
Lane Configurations	↖	↗		↖	↗		↖	↗		↖	↗	
Traffic Volume (veh/h)	136	115	28	236	384	8	64	934	37	25	966	353
Future Volume (veh/h)	136	115	28	236	384	8	64	934	37	25	966	353
Initial Q (Qb), veh	0	0	0	0	0	0	0	0	0	0	0	0
Ped-Bike Adj(A_pbT)	1.00		1.00	1.00		1.00	1.00		1.00	1.00		1.00
Parking Bus, Adj	1.00	1.00	1.00	1.00	1.00	1.00	1.00	1.00	1.00	1.00	1.00	1.00
Work Zone On Approach		No			No			No			No	
Adj Sat Flow, veh/h/ln	1870	1870	1870	1870	1870	1870	1870	1870	1870	1870	1870	1870
Adj Flow Rate, veh/h	136	115	0	236	384	8	64	934	37	25	966	353
Peak Hour Factor	1.00	1.00	1.00	1.00	1.00	1.00	1.00	1.00	1.00	1.00	1.00	1.00
Percent Heavy Veh, %	2	2	2	2	2	2	2	2	2	2	2	2
Cap, veh/h	466	1173		896	602	13	38	1093	43	74	801	290
Arrive On Green	0.26	0.33	0.00	0.26	0.33	0.33	0.31	0.31	0.31	0.31	0.31	0.31
Sat Flow, veh/h	1781	3647	0	1781	1825	38	416	3484	138	579	2552	925
Grp Volume(v), veh/h	136	115	0	236	0	392	64	476	495	25	670	649
Grp Sat Flow(s),veh/h/ln	1781	1777	0	1781	0	1863	416	1777	1845	579	1777	1700
Q Serve(g_s), s	11.6	4.3	0.0	11.9	0.0	33.9	0.0	47.8	47.8	8.0	59.6	59.6
Cycle Q Clear(g_c), s	11.6	4.3	0.0	11.9	0.0	33.9	59.6	47.8	47.8	55.8	59.6	59.6
Prop In Lane	1.00		0.00	1.00		0.02	1.00		0.07	1.00		0.54
Lane Grp Cap(c), veh/h	466	1173		896	0	615	38	557	579	74	557	533
V/C Ratio(X)	0.29	0.10		0.26	0.00	0.64	1.69	0.85	0.85	0.34	1.20	1.22
Avail Cap(c_a), veh/h	466	1173		896	0	615	38	557	579	74	557	533
HCM Platoon Ratio	1.00	1.00	1.00	1.00	1.00	1.00	1.00	1.00	1.00	1.00	1.00	1.00
Upstream Filter(I)	1.00	1.00	0.00	1.00	0.00	1.00	1.00	1.00	1.00	1.00	1.00	1.00
Uniform Delay (d), s/veh	56.1	44.1	0.0	18.3	0.0	54.0	95.0	61.1	61.1	87.3	65.2	65.2
Incr Delay (d2), s/veh	1.6	0.2	0.0	0.7	0.0	5.0	400.2	15.4	14.9	11.9	107.4	113.6
Initial Q Delay(d3),s/veh	0.0	0.0	0.0	0.0	0.0	0.0	0.0	0.0	0.0	0.0	0.0	0.0
%ile BackOfQ(95%),veh/ln	9.4	3.5	0.0	9.0	0.0	23.7	11.0	32.1	33.1	2.6	61.2	60.4
Unsig. Movement Delay, s/veh												
LnGrp Delay(d),s/veh	57.7	44.2	0.0	19.0	0.0	59.0	495.2	76.5	76.0	99.2	172.6	178.8
LnGrp LOS	E	D		B	A	E	F	E	E	F	F	F
Approach Vol, veh/h		251	A		628			1035			1344	
Approach Delay, s/veh		51.5			44.0			102.2			174.2	
Approach LOS		D			D			F			F	
Timer - Assigned Phs		2	3	4		6	7	8				
Phs Duration (G+Y+Rc), s		66.2	55.4	68.4		66.2	55.4	68.4				
Change Period (Y+Rc), s		* 6.6	* 5.7	* 5.7		* 6.6	* 5.7	* 5.7				
Max Green Setting (Gmax), s		* 60	* 50	* 63		* 60	* 50	* 63				
Max Q Clear Time (g_c+I1), s		61.6	13.9	6.3		61.6	13.6	35.9				
Green Ext Time (p_c), s		0.0	0.3	0.6		0.0	0.2	1.6				

Intersection Summary

HCM 6th Ctrl Delay	116.8
HCM 6th LOS	F

Notes

\* HCM 6th computational engine requires equal clearance times for the phases crossing the barrier.  
 Unsignalized Delay for [EBR] is excluded from calculations of the approach delay and intersection delay.

PM Signal Timings  
 3: Salzedo St. & University Dr.

09/20/2021

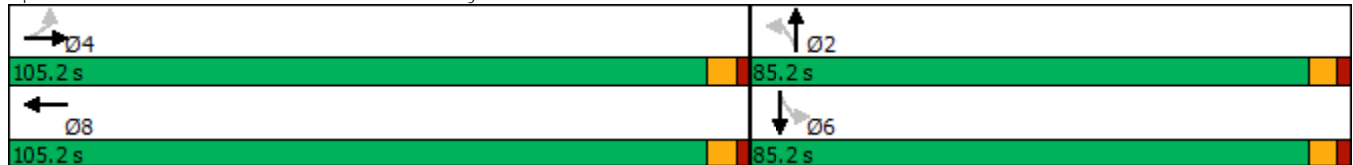


Lane Group	EBL	EBT	WBT	NBL	NBT	SBL	SBT
Lane Configurations		↕↕	↕↔	↔	↔		↕↔
Traffic Volume (vph)	42	125	425	5	10	12	0
Future Volume (vph)	42	125	425	5	10	12	0
Turn Type	Perm	NA	NA	Perm	NA	Perm	NA
Protected Phases		4	8		2		6
Permitted Phases	4			2		6	
Detector Phase	4	4	8	2	2	6	6
Switch Phase							
Minimum Initial (s)	12.0	12.0	12.0	7.0	7.0	7.0	7.0
Minimum Split (s)	24.2	24.2	24.2	24.2	24.2	24.2	24.2
Total Split (s)	105.2	105.2	105.2	85.2	85.2	85.2	85.2
Total Split (%)	55.3%	55.3%	55.3%	44.7%	44.7%	44.7%	44.7%
Yellow Time (s)	4.0	4.0	4.0	4.0	4.0	4.0	4.0
All-Red Time (s)	2.2	2.2	2.2	2.2	2.2	2.2	2.2
Lost Time Adjust (s)		0.0	0.0	0.0	0.0		0.0
Total Lost Time (s)		6.2	6.2	6.2	6.2		6.2
Lead/Lag							
Lead-Lag Optimize?							
Recall Mode	None	None	None	Max	Max	Max	Max

Intersection Summary

Cycle Length: 190.4  
 Actuated Cycle Length: 107.9  
 Natural Cycle: 50  
 Control Type: Semi Act-Uncoord

Splits and Phases: 3: Salzedo St. & University Dr.





PM Signal Timings  
6: SR 953 & University Dr.

09/20/2021



Lane Group	EBL	EBT	WBL	WBT	NBL	NBT	SBL	SBT
Lane Configurations	↖	↗	↖	↗	↖	↗	↗	↘
Traffic Volume (vph)	156	140	280	430	66	984	26	1001
Future Volume (vph)	156	140	280	430	66	984	26	1001
Turn Type	Prot	NA	pm+pt	NA	Perm	NA	Perm	NA
Protected Phases	7	4	3	8		2		6
Permitted Phases			8		2		6	
Detector Phase	7	4	3	8	2	2	6	6
Switch Phase								
Minimum Initial (s)	5.0	5.0	5.0	5.0	7.0	7.0	7.0	7.0
Minimum Split (s)	10.7	35.7	10.7	35.7	36.6	36.6	36.6	36.6
Total Split (s)	55.4	68.4	55.4	68.4	66.2	66.2	66.2	66.2
Total Split (%)	29.2%	36.0%	29.2%	36.0%	34.8%	34.8%	34.8%	34.8%
Yellow Time (s)	3.7	3.7	3.7	3.7	4.4	4.4	4.4	4.4
All-Red Time (s)	2.0	2.0	2.0	2.0	2.2	2.2	2.2	2.2
Lost Time Adjust (s)	0.0	0.0	0.0	0.0	0.0	0.0	0.0	0.0
Total Lost Time (s)	5.7	5.7	5.7	5.7	6.6	6.6	6.6	6.6
Lead/Lag	Lead	Lag	Lead	Lag				
Lead-Lag Optimize?	Yes	Yes	Yes	Yes				
Recall Mode	Max	Max	Max	Max	Max	Max	Max	Max

Intersection Summary

Cycle Length: 190  
 Actuated Cycle Length: 190  
 Offset: 0 (0%), Referenced to phase 2:NBTL and 6:SBTL, Start of Green  
 Natural Cycle: 95  
 Control Type: Pretimed

Splits and Phases: 6: SR 953 & University Dr.



## Scenario 2 - AM

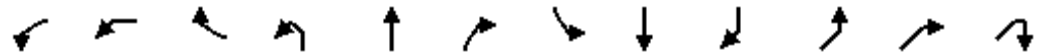
SC 2 AM

3: Salzedo St. & University Dr.

09/22/2021



Movement	EBL	EBT	EBR	WBL	WBT	WBR	NBL	NBT	NBR	SBL	SBT	SBR
Lane Configurations		↕↕			↕↕		↕	↕			↕↕	
Traffic Volume (veh/h)	149	260	0	0	165	9	4	13	16	24	0	71
Future Volume (veh/h)	149	260	0	0	165	9	4	13	16	24	0	71
Initial Q (Qb), veh	0	0	0	0	0	0	0	0	0	0	0	0
Ped-Bike Adj(A_pbT)	0.99		1.00	1.00		0.99	1.00		1.00	1.00		1.00
Parking Bus, Adj	1.00	1.00	1.00	1.00	1.00	1.00	1.00	1.00	1.00	1.00	1.00	1.00
Work Zone On Approach		No			No			No			No	
Adj Sat Flow, veh/h/ln	1870	1870	0	0	1870	1870	1870	1870	1870	1870	1870	1870
Adj Flow Rate, veh/h	149	260	0	0	165	9	4	13	16	24	0	71
Peak Hour Factor	1.00	1.00	1.00	1.00	1.00	1.00	1.00	1.00	1.00	1.00	1.00	1.00
Percent Heavy Veh, %	2	2	0	0	2	2	2	2	2	2	2	2
Cap, veh/h	282	461	0	0	780	42	878	427	525	254	42	647
Arrive On Green	0.23	0.23	0.00	0.00	0.23	0.23	0.56	0.56	0.56	0.56	0.00	0.56
Sat Flow, veh/h	778	2109	0	0	3519	186	1326	761	937	316	74	1155
Grp Volume(v), veh/h	213	196	0	0	85	89	4	0	29	95	0	0
Grp Sat Flow(s),veh/h/ln	1185	1617	0	0	1777	1834	1326	0	1698	1545	0	0
Q Serve(g_s), s	8.1	6.2	0.0	0.0	2.3	2.3	0.0	0.0	0.4	0.0	0.0	0.0
Cycle Q Clear(g_c), s	10.4	6.2	0.0	0.0	2.3	2.3	0.1	0.0	0.4	1.6	0.0	0.0
Prop In Lane	0.70		0.00	0.00		0.10	1.00		0.55	0.25		0.75
Lane Grp Cap(c), veh/h	374	368	0	0	404	417	878	0	952	943	0	0
V/C Ratio(X)	0.57	0.53	0.00	0.00	0.21	0.21	0.00	0.00	0.03	0.10	0.00	0.00
Avail Cap(c_a), veh/h	1212	1376	0	0	1512	1561	878	0	952	943	0	0
HCM Platoon Ratio	1.00	1.00	1.00	1.00	1.00	1.00	1.00	1.00	1.00	1.00	1.00	1.00
Upstream Filter(I)	1.00	1.00	0.00	0.00	1.00	1.00	1.00	0.00	1.00	1.00	0.00	0.00
Uniform Delay (d), s/veh	22.1	19.9	0.0	0.0	18.3	18.3	5.7	0.0	5.8	6.0	0.0	0.0
Incr Delay (d2), s/veh	0.5	0.4	0.0	0.0	0.4	0.4	0.0	0.0	0.1	0.2	0.0	0.0
Initial Q Delay(d3),s/veh	0.0	0.0	0.0	0.0	0.0	0.0	0.0	0.0	0.0	0.0	0.0	0.0
%ile BackOfQ(95%),veh/ln	4.7	4.0	0.0	0.0	1.6	1.7	0.0	0.0	0.3	0.9	0.0	0.0
Unsig. Movement Delay, s/veh												
LnGrp Delay(d),s/veh	22.6	20.3	0.0	0.0	18.7	18.7	5.7	0.0	5.8	6.2	0.0	0.0
LnGrp LOS	C	C	A	A	B	B	A	A	A	A	A	A
Approach Vol, veh/h		409			174			33				95
Approach Delay, s/veh		21.5			18.7			5.8				6.2
Approach LOS		C			B			A				A
Timer - Assigned Phs		2		4		6		8				
Phs Duration (G+Y+Rc), s		39.0		19.5		39.0		19.5				
Change Period (Y+Rc), s		* 6.2		* 6.2		* 6.2		* 6.2				
Max Green Setting (Gmax), s		* 33		* 50		* 33		* 50				
Max Q Clear Time (g_c+I1), s		2.4		12.4		3.6		4.3				
Green Ext Time (p_c), s		0.2		0.9		0.2		1.5				
<b>Intersection Summary</b>												
HCM 6th Ctrl Delay				18.0								
HCM 6th LOS				B								
<b>Notes</b>												
* HCM 6th computational engine requires equal clearance times for the phases crossing the barrier.												



Movement	WBL2	WBL	WBR	NBL	NBT	NBR	SBL	SBT	SBR	NEL	NER	NER2
Lane Configurations												
Traffic Volume (veh/h)	81	145	19	19	1024	103	24	982	193	322	337	13
Future Volume (veh/h)	81	145	19	19	1024	103	24	982	193	322	337	13
Initial Q (Qb), veh	0	0	0	0	0	0	0	0	0	0	0	0
Ped-Bike Adj(A_pbT)	0.99	0.99	0.99	1.00		1.00	1.00		1.00	1.00	1.00	1.00
Parking Bus, Adj	1.00	1.00	1.00	1.00	1.00	1.00	1.00	1.00	1.00	1.00	1.00	1.00
Work Zone On Approach		No			No			No		No		
Adj Sat Flow, veh/h/ln	1870	1870	1870	1870	1870	1870	1870	1870	1870	1870	1870	1870
Adj Flow Rate, veh/h	81	81	19	19	1024	103	24	982	193	322	0	0
Peak Hour Factor	1.00	1.00	1.00	1.00	1.00	1.00	1.00	1.00	1.00	1.00	1.00	1.00
Percent Heavy Veh, %	2	2	2	2	2	2	2	2	2	2	2	2
Cap, veh/h	967	967	70	38	1023	103	38	928	182	466		
Arrive On Green	0.26	0.26	0.33	0.31	0.31	0.31	0.31	0.31	0.31	0.26	0.00	0.00
Sat Flow, veh/h	1781	1781	212	477	3260	328	500	2960	581	1781	0	0
Grp Volume(v), veh/h	81	81	164	19	558	569	24	589	586	322	0	0
Grp Sat Flow(s),veh/h/ln	1781	1781	1830	477	1777	1811	500	1777	1764	1781	0	0
Q Serve(g_s), s	3.7	3.7	12.5	0.0	59.6	59.6	0.0	59.6	59.6	31.0	0.0	0.0
Cycle Q Clear(g_c), s	3.7	3.7	12.5	59.6	59.6	59.6	59.6	59.6	59.6	31.0	0.0	0.0
Prop In Lane	1.00	1.00	0.12	1.00		0.18	1.00		0.33	1.00	0.00	0.00
Lane Grp Cap(c), veh/h	967	967	604	38	557	568	38	557	553	466		
V/C Ratio(X)	0.08	0.08	0.27	0.50	1.00	1.00	0.63	1.06	1.06	0.69		
Avail Cap(c_a), veh/h	967	967	604	38	557	568	38	557	553	466		
HCM Platoon Ratio	1.00	1.00	1.00	1.00	1.00	1.00	1.00	1.00	1.00	1.00	1.00	1.00
Upstream Filter(I)	1.00	1.00	1.00	1.00	1.00	1.00	1.00	1.00	1.00	1.00	0.00	0.00
Uniform Delay (d), s/veh	16.6	16.6	46.8	95.0	65.2	65.2	95.0	65.2	65.2	63.2	0.0	0.0
Incr Delay (d2), s/veh	0.2	0.2	1.1	40.5	38.4	38.2	60.1	54.0	54.9	8.2	0.0	0.0
Initial Q Delay(d3),s/veh	0.0	0.0	0.0	0.0	0.0	0.0	0.0	0.0	0.0	0.0	0.0	0.0
%ile BackOfQ(95%),veh/ln	2.9	2.9	10.1	2.5	42.5	43.2	3.3	46.9	46.9	21.6	0.0	0.0
Unsig. Movement Delay, s/veh												
LnGrp Delay(d),s/veh	16.8	16.8	48.0	135.5	103.6	103.4	155.1	119.2	120.1	71.4	0.0	0.0
LnGrp LOS	B	B	D	F	F	F	F	F	F	E		
Approach Vol, veh/h	245	245			1146			1199		322	A	A
Approach Delay, s/veh	37.6	37.6			104.0			120.4		71.4		
Approach LOS	D	D			F			F		E		
Timer - Assigned Phs		2	3	4		6	7	8				
Phs Duration (G+Y+Rc), s		66.2	55.4	68.4		66.2	55.4	68.4				
Change Period (Y+Rc), s		* 6.6	* 5.7	* 5.7		* 6.6	* 5.7	* 5.7				
Max Green Setting (Gmax), s		* 60	* 50	* 63		* 60	* 50	* 63				
Max Q Clear Time (g_c+I1), s		61.6	5.7	0.0		61.6	33.0	14.5				
Green Ext Time (p_c), s		0.0	0.1	0.0		0.0	0.4	0.2				

Intersection Summary

HCM 6th Ctrl Delay	101.6
HCM 6th LOS	F

Notes

\* HCM 6th computational engine requires equal clearance times for the phases crossing the barrier.  
 Unsignalized Delay for [NER2] is excluded from calculations of the approach delay and intersection delay.

SC 2 AM  
12: Salzedo St. & Catalonia Ave.

09/22/2021

Intersection	
Intersection Delay, s/veh	9.4
Intersection LOS	A

Movement	EBL	EBT	EBR	WBL	WBT	WBR	NBL	NBT	NBR	SBL	SBT	SBR
Lane Configurations		↕			↕			↕			↕	
Traffic Vol, veh/h	50	90	8	8	43	41	6	201	41	14	127	14
Future Vol, veh/h	50	90	8	8	43	41	6	201	41	14	127	14
Peak Hour Factor	1.00	1.00	1.00	1.00	1.00	1.00	1.00	1.00	1.00	1.00	1.00	1.00
Heavy Vehicles, %	2	2	2	2	2	2	2	2	2	2	2	2
Mvmt Flow	50	90	8	8	43	41	6	201	41	14	127	14
Number of Lanes	0	1	0	0	1	0	0	1	0	0	1	0

Approach	EB	WB	NB	SB
Opposing Approach	WB	EB	SB	NB
Opposing Lanes	1	1	1	1
Conflicting Approach Left	SB	NB	EB	WB
Conflicting Lanes Left	1	1	1	1
Conflicting Approach Right	NB	SB	WB	EB
Conflicting Lanes Right	1	1	1	1
HCM Control Delay	9.4	8.6	9.8	9.1
HCM LOS	A	A	A	A

Lane	NBLn1	EBLn1	WBLn1	SBLn1
Vol Left, %	2%	34%	9%	9%
Vol Thru, %	81%	61%	47%	82%
Vol Right, %	17%	5%	45%	9%
Sign Control	Stop	Stop	Stop	Stop
Traffic Vol by Lane	248	148	92	155
LT Vol	6	50	8	14
Through Vol	201	90	43	127
RT Vol	41	8	41	14
Lane Flow Rate	248	148	92	155
Geometry Grp	1	1	1	1
Degree of Util (X)	0.318	0.207	0.123	0.206
Departure Headway (Hd)	4.623	5.029	4.829	4.789
Convergence, Y/N	Yes	Yes	Yes	Yes
Cap	774	709	737	746
Service Time	2.675	3.09	2.896	2.845
HCM Lane V/C Ratio	0.32	0.209	0.125	0.208
HCM Control Delay	9.8	9.4	8.6	9.1
HCM Lane LOS	A	A	A	A
HCM 95th-tile Q	1.4	0.8	0.4	0.8

Intersection												
Int Delay, s/veh	3.6											
Movement	EBL	EBT	EBR	WBL	WBT	WBR	NBL	NBT	NBR	SBL	SBT	SBR
Lane Configurations		↕			↕			↕			↕	
Traffic Vol, veh/h	12	34	6	5	19	44	6	175	13	29	96	7
Future Vol, veh/h	12	34	6	5	19	44	6	175	13	29	96	7
Conflicting Peds, #/hr	2	0	1	1	0	2	2	0	8	8	0	2
Sign Control	Stop	Stop	Stop	Stop	Stop	Stop	Free	Free	Free	Free	Free	Free
RT Channelized	-	-	None	-	-	None	-	-	None	-	-	None
Storage Length	-	-	-	-	-	-	-	-	-	-	-	-
Veh in Median Storage, #	-	0	-	-	0	-	-	0	-	-	0	-
Grade, %	-	0	-	-	0	-	-	0	-	-	0	-
Peak Hour Factor	100	100	100	100	100	100	100	100	100	100	100	100
Heavy Vehicles, %	2	2	2	2	2	2	2	2	2	2	2	2
Mvmt Flow	12	34	6	5	19	44	6	175	13	29	96	7

Major/Minor	Minor2		Minor1		Major1		Major2					
Conflicting Flow All	387	368	103	381	365	192	105	0	0	196	0	0
Stage 1	160	160	-	202	202	-	-	-	-	-	-	-
Stage 2	227	208	-	179	163	-	-	-	-	-	-	-
Critical Hdwy	7.12	6.52	6.22	7.12	6.52	6.22	4.12	-	-	4.12	-	-
Critical Hdwy Stg 1	6.12	5.52	-	6.12	5.52	-	-	-	-	-	-	-
Critical Hdwy Stg 2	6.12	5.52	-	6.12	5.52	-	-	-	-	-	-	-
Follow-up Hdwy	3.518	4.018	3.318	3.518	4.018	3.318	2.218	-	-	2.218	-	-
Pot Cap-1 Maneuver	572	561	952	577	563	850	1486	-	-	1377	-	-
Stage 1	842	766	-	800	734	-	-	-	-	-	-	-
Stage 2	776	730	-	823	763	-	-	-	-	-	-	-
Platoon blocked, %								-	-	-	-	-
Mov Cap-1 Maneuver	514	540	949	530	542	842	1483	-	-	1367	-	-
Mov Cap-2 Maneuver	514	540	-	530	542	-	-	-	-	-	-	-
Stage 1	836	747	-	790	724	-	-	-	-	-	-	-
Stage 2	711	721	-	762	744	-	-	-	-	-	-	-

Approach	EB		WB		NB		SB	
HCM Control Delay, s	12.1		10.7		0.2		1.7	
HCM LOS	B		B					

Minor Lane/Major Mvmt	NBL	NBT	NBR	EBLn1WBLn1	SBL	SBT	SBR
Capacity (veh/h)	1483	-	-	561	703	1367	-
HCM Lane V/C Ratio	0.004	-	-	0.093	0.097	0.021	-
HCM Control Delay (s)	7.4	0	-	12.1	10.7	7.7	0
HCM Lane LOS	A	A	-	B	B	A	A
HCM 95th %tile Q(veh)	0	-	-	0.3	0.3	0.1	-

Intersection						
Int Delay, s/veh	3.9					
Movement	WBL	WBR	NBT	NBR	SBL	SBT
Lane Configurations						
Traffic Vol, veh/h	20	39	1359	24	109	1324
Future Vol, veh/h	20	39	1359	24	109	1324
Conflicting Peds, #/hr	0	0	0	0	0	0
Sign Control	Stop	Stop	Free	Free	Free	Free
RT Channelized	-	None	-	None	-	None
Storage Length	0	-	-	-	50	-
Veh in Median Storage, #	0	-	0	-	-	0
Grade, %	0	-	0	-	-	0
Peak Hour Factor	100	100	100	100	100	100
Heavy Vehicles, %	2	2	2	2	2	2
Mvmt Flow	20	39	1359	24	109	1324

Major/Minor	Minor1	Major1	Major2		
Conflicting Flow All	2251	692	0	0	1383
Stage 1	1371	-	-	-	-
Stage 2	880	-	-	-	-
Critical Hdwy	6.84	6.94	-	-	4.14
Critical Hdwy Stg 1	5.84	-	-	-	-
Critical Hdwy Stg 2	5.84	-	-	-	-
Follow-up Hdwy	3.52	3.32	-	-	2.22
Pot Cap-1 Maneuver	35	386	-	-	491
Stage 1	201	-	-	-	-
Stage 2	366	-	-	-	-
Platoon blocked, %			-	-	-
Mov Cap-1 Maneuver	27	386	-	-	491
Mov Cap-2 Maneuver	27	-	-	-	-
Stage 1	201	-	-	-	-
Stage 2	285	-	-	-	-

Approach	WB	NB	SB
HCM Control Delay, s	165.1	0	1.1
HCM LOS	F		

Minor Lane/Major Mvmt	NBT	NBRWBLn1	SBL	SBT
Capacity (veh/h)	-	-	70	491
HCM Lane V/C Ratio	-	-	0.843	0.222
HCM Control Delay (s)	-	-	165.1	14.4
HCM Lane LOS	-	-	F	B
HCM 95th %tile Q(veh)	-	-	4.1	0.8

SC 2 AM  
16: Malaga Ave. & SR 953

09/22/2021

Intersection						
Int Delay, s/veh	1					
Movement	WBL	WBR	NBT	NBR	SBL	SBT
Lane Configurations	T		T		T	
Traffic Vol, veh/h	7	16	1288	7	35	1092
Future Vol, veh/h	7	16	1288	7	35	1092
Conflicting Peds, #/hr	0	0	0	0	0	0
Sign Control	Stop	Stop	Free	Free	Free	Free
RT Channelized	-	None	-	None	-	None
Storage Length	0	-	-	-	-	-
Veh in Median Storage, #	0	-	0	-	-	0
Grade, %	0	-	0	-	-	0
Peak Hour Factor	100	100	100	100	100	100
Heavy Vehicles, %	2	2	2	2	2	2
Mvmt Flow	7	16	1288	7	35	1092

Major/Minor	Minor1	Major1	Major2		
Conflicting Flow All	1908	648	0	0	1295
Stage 1	1292	-	-	-	-
Stage 2	616	-	-	-	-
Critical Hdwy	6.84	6.94	-	-	4.14
Critical Hdwy Stg 1	5.84	-	-	-	-
Critical Hdwy Stg 2	5.84	-	-	-	-
Follow-up Hdwy	3.52	3.32	-	-	2.22
Pot Cap-1 Maneuver	60	413	-	-	531
Stage 1	221	-	-	-	-
Stage 2	501	-	-	-	-
Platoon blocked, %			-	-	-
Mov Cap-1 Maneuver	50	413	-	-	531
Mov Cap-2 Maneuver	50	-	-	-	-
Stage 1	221	-	-	-	-
Stage 2	417	-	-	-	-

Approach	WB	NB	SB
HCM Control Delay, s	38.9	0	1.3
HCM LOS	E		

Minor Lane/Major Mvmt	NBT	NBRWBLn1	SBL	SBT
Capacity (veh/h)	-	-	129	531
HCM Lane V/C Ratio	-	-	0.178	0.066
HCM Control Delay (s)	-	-	38.9	12.3
HCM Lane LOS	-	-	E	B
HCM 95th %tile Q(veh)	-	-	0.6	0.2



SC 2 AM  
17: SR 953 & Catalonia Avenue

09/22/2021

Intersection						
Int Delay, s/veh	1.2					
Movement	EBL	EBR	NBL	NBT	SBT	SBR
Lane Configurations	T		T		T	
Traffic Vol, veh/h	17	31	25	1359	1324	6
Future Vol, veh/h	17	31	25	1359	1324	6
Conflicting Peds, #/hr	0	0	0	0	0	0
Sign Control	Stop	Stop	Free	Free	Free	Free
RT Channelized	-	None	-	None	-	None
Storage Length	0	-	50	-	-	-
Veh in Median Storage, #	0	-	-	0	0	-
Grade, %	0	-	-	0	0	-
Peak Hour Factor	100	100	100	100	100	100
Heavy Vehicles, %	2	2	2	2	2	2
Mvmt Flow	17	31	25	1359	1324	6

Major/Minor	Minor2	Major1	Major2			
Conflicting Flow All	2057	665	1330	0	-	0
Stage 1	1327	-	-	-	-	-
Stage 2	730	-	-	-	-	-
Critical Hdwy	6.84	6.94	4.14	-	-	-
Critical Hdwy Stg 1	5.84	-	-	-	-	-
Critical Hdwy Stg 2	5.84	-	-	-	-	-
Follow-up Hdwy	3.52	3.32	2.22	-	-	-
Pot Cap-1 Maneuver	48	403	515	-	-	-
Stage 1	212	-	-	-	-	-
Stage 2	438	-	-	-	-	-
Platoon blocked, %				-	-	-
Mov Cap-1 Maneuver	46	403	515	-	-	-
Mov Cap-2 Maneuver	46	-	-	-	-	-
Stage 1	202	-	-	-	-	-
Stage 2	438	-	-	-	-	-

Approach	EB	NB	SB
HCM Control Delay, s	62.6	0.2	0
HCM LOS	F		

Minor Lane/Major Mvmt	NBL	NBT	EBLn1	SBT	SBR
Capacity (veh/h)	515	-	108	-	-
HCM Lane V/C Ratio	0.049	-	0.444	-	-
HCM Control Delay (s)	12.3	-	62.6	-	-
HCM Lane LOS	B	-	F	-	-
HCM 95th %tile Q(veh)	0.2	-	1.9	-	-

SC 2 AM  
18: SR 953 & Malaga Avenue

09/22/2021

Intersection						
Int Delay, s/veh	0.5					
Movement	EBL	EBR	NBL	NBT	SBT	SBR
Lane Configurations	TT		T	TT	TT	
Traffic Vol, veh/h	11	15	18	1288	1092	13
Future Vol, veh/h	11	15	18	1288	1092	13
Conflicting Peds, #/hr	0	4	1	0	0	1
Sign Control	Stop	Stop	Free	Free	Free	Free
RT Channelized	-	None	-	None	-	None
Storage Length	0	-	50	-	-	-
Veh in Median Storage, #	0	-	-	0	0	-
Grade, %	0	-	-	0	0	-
Peak Hour Factor	100	100	100	100	100	100
Heavy Vehicles, %	2	2	2	2	2	2
Mvmt Flow	11	15	18	1288	1092	13

Major/Minor	Minor2	Major1	Major2			
Conflicting Flow All	1780	558	1106	0	-	0
Stage 1	1100	-	-	-	-	-
Stage 2	680	-	-	-	-	-
Critical Hdwy	6.84	6.94	4.14	-	-	-
Critical Hdwy Stg 1	5.84	-	-	-	-	-
Critical Hdwy Stg 2	5.84	-	-	-	-	-
Follow-up Hdwy	3.52	3.32	2.22	-	-	-
Pot Cap-1 Maneuver	73	473	627	-	-	-
Stage 1	280	-	-	-	-	-
Stage 2	465	-	-	-	-	-
Platoon blocked, %				-	-	-
Mov Cap-1 Maneuver	71	471	626	-	-	-
Mov Cap-2 Maneuver	71	-	-	-	-	-
Stage 1	272	-	-	-	-	-
Stage 2	465	-	-	-	-	-

Approach	EB	NB	SB
HCM Control Delay, s	36.8	0.2	0
HCM LOS	E		

Minor Lane/Major Mvmt	NBL	NBT	EBLn1	SBT	SBR
Capacity (veh/h)	626	-	139	-	-
HCM Lane V/C Ratio	0.029	-	0.187	-	-
HCM Control Delay (s)	10.9	-	36.8	-	-
HCM Lane LOS	B	-	E	-	-
HCM 95th %tile Q(veh)	0.1	-	0.7	-	-

## Scenario 2 - PM

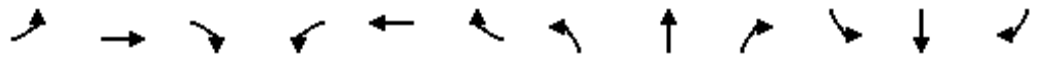
SC 2 PM

3: Salzedo St. & University Dr.

09/22/2021



Movement	EBL	EBT	EBR	WBL	WBT	WBR	NBL	NBT	NBR	SBL	SBT	SBR
Lane Configurations		↕↕			↕↕		↕	↕			↕↕	
Traffic Volume (veh/h)	42	125	0	0	425	9	5	9	10	12	0	223
Future Volume (veh/h)	42	125	0	0	425	9	5	9	10	12	0	223
Initial Q (Qb), veh	0	0	0	0	0	0	0	0	0	0	0	0
Ped-Bike Adj(A_pbT)	0.99		1.00	1.00		0.97	1.00		1.00	1.00		1.00
Parking Bus, Adj	1.00	1.00	1.00	1.00	1.00	1.00	1.00	1.00	1.00	1.00	1.00	1.00
Work Zone On Approach		No			No			No			No	
Adj Sat Flow, veh/h/ln	1885	1885	0	0	1885	1885	1885	1885	1885	1885	1885	1885
Adj Flow Rate, veh/h	42	125	0	0	425	9	5	9	10	12	0	223
Peak Hour Factor	1.00	1.00	1.00	1.00	1.00	1.00	1.00	1.00	1.00	1.00	1.00	1.00
Percent Heavy Veh, %	1	1	0	0	1	1	1	1	1	1	1	1
Cap, veh/h	96	331	0	0	616	13	904	583	647	68	24	1080
Arrive On Green	0.17	0.17	0.00	0.00	0.17	0.17	0.72	0.72	0.72	0.72	0.00	0.72
Sat Flow, veh/h	251	2010	0	0	3678	76	1164	814	905	48	34	1510
Grp Volume(v), veh/h	69	98	0	0	212	222	5	0	19	235	0	0
Grp Sat Flow(s),veh/h/ln	546	1630	0	0	1791	1869	1164	0	1719	1591	0	0
Q Serve(g_s), s	4.3	5.8	0.0	0.0	12.3	12.3	0.0	0.0	0.4	0.0	0.0	0.0
Cycle Q Clear(g_c), s	16.6	5.8	0.0	0.0	12.3	12.3	0.1	0.0	0.4	5.4	0.0	0.0
Prop In Lane	0.60		0.00	0.00		0.04	1.00		0.53	0.05		0.95
Lane Grp Cap(c), veh/h	146	280	0	0	308	321	904	0	1230	1173	0	0
V/C Ratio(X)	0.48	0.35	0.00	0.00	0.69	0.69	0.01	0.00	0.02	0.20	0.00	0.00
Avail Cap(c_a), veh/h	1004	1462	0	0	1606	1676	904	0	1230	1173	0	0
HCM Platoon Ratio	1.00	1.00	1.00	1.00	1.00	1.00	1.00	1.00	1.00	1.00	1.00	1.00
Upstream Filter(I)	1.00	1.00	0.00	0.00	1.00	1.00	1.00	0.00	1.00	1.00	0.00	0.00
Uniform Delay (d), s/veh	46.3	40.2	0.0	0.0	42.9	42.9	4.5	0.0	4.5	5.2	0.0	0.0
Incr Delay (d2), s/veh	0.9	0.3	0.0	0.0	1.0	1.0	0.0	0.0	0.0	0.4	0.0	0.0
Initial Q Delay(d3),s/veh	0.0	0.0	0.0	0.0	0.0	0.0	0.0	0.0	0.0	0.0	0.0	0.0
%ile BackOfQ(95%),veh/ln	3.4	4.2	0.0	0.0	9.3	9.7	0.1	0.0	0.2	3.1	0.0	0.0
Unsig. Movement Delay, s/veh												
LnGrp Delay(d),s/veh	47.2	40.5	0.0	0.0	44.0	43.9	4.5	0.0	4.5	5.6	0.0	0.0
LnGrp LOS	D	D	A	A	D	D	A	A	A	A	A	A
Approach Vol, veh/h		167			434			24			235	
Approach Delay, s/veh		43.3			43.9			4.5			5.6	
Approach LOS		D			D			A			A	
Timer - Assigned Phs		2		4		6		8				
Phs Duration (G+Y+Rc), s		85.2		25.2		85.2		25.2				
Change Period (Y+Rc), s		* 6.2		* 6.2		* 6.2		* 6.2				
Max Green Setting (Gmax), s		* 79		* 99		* 79		* 99				
Max Q Clear Time (g_c+I1), s		2.4		18.6		7.4		14.3				
Green Ext Time (p_c), s		0.2		0.4		2.5		0.9				
<b>Intersection Summary</b>												
HCM 6th Ctrl Delay				32.2								
HCM 6th LOS				C								
<b>Notes</b>												
* HCM 6th computational engine requires equal clearance times for the phases crossing the barrier.												



Movement	EBL	EBT	EBR	WBL	WBT	WBR	NBL	NBT	NBR	SBL	SBT	SBR
Lane Configurations	↖	↗		↖	↗		↖	↗		↖	↗	
Traffic Volume (veh/h)	142	140	29	279	430	9	66	973	63	26	994	387
Future Volume (veh/h)	142	140	29	279	430	9	66	973	63	26	994	387
Initial Q (Qb), veh	0	0	0	0	0	0	0	0	0	0	0	0
Ped-Bike Adj(A_pbT)	1.00		1.00	1.00		1.00	1.00		1.00	1.00		1.00
Parking Bus, Adj	1.00	1.00	1.00	1.00	1.00	1.00	1.00	1.00	1.00	1.00	1.00	1.00
Work Zone On Approach		No			No			No			No	
Adj Sat Flow, veh/h/ln	1870	1870	1870	1870	1870	1870	1870	1870	1870	1870	1870	1870
Adj Flow Rate, veh/h	142	140	0	279	430	9	66	973	63	26	994	387
Peak Hour Factor	1.00	1.00	1.00	1.00	1.00	1.00	1.00	1.00	1.00	1.00	1.00	1.00
Percent Heavy Veh, %	2	2	2	2	2	2	2	2	2	2	2	2
Cap, veh/h	466	1173		881	602	13	38	1063	69	58	786	302
Arrive On Green	0.26	0.33	0.00	0.26	0.33	0.33	0.31	0.31	0.31	0.31	0.31	0.31
Sat Flow, veh/h	1781	3647	0	1781	1825	38	392	3388	219	545	2506	964
Grp Volume(v), veh/h	142	140	0	279	0	439	66	510	526	26	701	680
Grp Sat Flow(s),veh/h/ln	1781	1777	0	1781	0	1863	392	1777	1830	545	1777	1693
Q Serve(g_s), s	12.2	5.2	0.0	14.4	0.0	39.2	0.0	52.5	52.5	7.1	59.6	59.6
Cycle Q Clear(g_c), s	12.2	5.2	0.0	14.4	0.0	39.2	59.6	52.5	52.5	59.6	59.6	59.6
Prop In Lane	1.00		0.00	1.00		0.02	1.00		0.12	1.00		0.57
Lane Grp Cap(c), veh/h	466	1173		881	0	615	38	557	574	58	557	531
V/C Ratio(X)	0.30	0.12		0.32	0.00	0.71	1.74	0.92	0.92	0.45	1.26	1.28
Avail Cap(c_a), veh/h	466	1173		881	0	615	38	557	574	58	557	531
HCM Platoon Ratio	1.00	1.00	1.00	1.00	1.00	1.00	1.00	1.00	1.00	1.00	1.00	1.00
Upstream Filter(I)	1.00	1.00	0.00	1.00	0.00	1.00	1.00	1.00	1.00	1.00	1.00	1.00
Uniform Delay (d), s/veh	56.3	44.4	0.0	18.9	0.0	55.8	95.0	62.8	62.8	92.3	65.2	65.2
Incr Delay (d2), s/veh	1.7	0.2	0.0	0.9	0.0	6.9	422.0	22.1	21.7	23.0	130.3	139.8
Initial Q Delay(d3),s/veh	0.0	0.0	0.0	0.0	0.0	0.0	0.0	0.0	0.0	0.0	0.0	0.0
%ile BackOfQ(95%),veh/ln	9.7	4.3	0.0	10.5	0.0	27.1	11.4	35.8	36.7	3.0	67.3	66.8
Unsig. Movement Delay, s/veh												
LnGrp Delay(d),s/veh	58.0	44.6	0.0	19.8	0.0	62.7	517.0	84.9	84.4	115.2	195.5	205.0
LnGrp LOS	E	D		B	A	E	F	F	F	F	F	F
Approach Vol, veh/h		282	A		718			1102			1407	
Approach Delay, s/veh		51.3			46.1			110.6			198.6	
Approach LOS		D			D			F			F	
Timer - Assigned Phs		2	3	4		6	7	8				
Phs Duration (G+Y+Rc), s		66.2	55.4	68.4		66.2	55.4	68.4				
Change Period (Y+Rc), s		* 6.6	* 5.7	* 5.7		* 6.6	* 5.7	* 5.7				
Max Green Setting (Gmax), s		* 60	* 50	* 63		* 60	* 50	* 63				
Max Q Clear Time (g_c+I1), s		61.6	16.4	7.2		61.6	14.2	41.2				
Green Ext Time (p_c), s		0.0	0.4	0.8		0.0	0.2	1.8				

Intersection Summary

HCM 6th Ctrl Delay	127.9
HCM 6th LOS	F

Notes

\* HCM 6th computational engine requires equal clearance times for the phases crossing the barrier.  
 Unsignalized Delay for [EBR] is excluded from calculations of the approach delay and intersection delay.

Intersection	
Intersection Delay, s/veh	9.6
Intersection LOS	A

Movement	EBL	EBT	EBR	WBL	WBT	WBR	NBL	NBT	NBR	SBL	SBT	SBR
Lane Configurations		↕			↕			↕			↕	
Traffic Vol, veh/h	21	62	9	17	99	32	5	80	42	19	228	37
Future Vol, veh/h	21	62	9	17	99	32	5	80	42	19	228	37
Peak Hour Factor	1.00	1.00	1.00	1.00	1.00	1.00	1.00	1.00	1.00	1.00	1.00	1.00
Heavy Vehicles, %	3	3	3	3	3	3	3	3	3	3	3	3
Mvmt Flow	21	62	9	17	99	32	5	80	42	19	228	37
Number of Lanes	0	1	0	0	1	0	0	1	0	0	1	0

Approach	EB	WB	NB	SB
Opposing Approach	WB	EB	SB	NB
Opposing Lanes	1	1	1	1
Conflicting Approach Left	SB	NB	EB	WB
Conflicting Lanes Left	1	1	1	1
Conflicting Approach Right	NB	SB	WB	EB
Conflicting Lanes Right	1	1	1	1
HCM Control Delay	8.9	9.2	8.7	10.4
HCM LOS	A	A	A	B

Lane	NBLn1	EBLn1	WBLn1	SBLn1
Vol Left, %	4%	23%	11%	7%
Vol Thru, %	63%	67%	67%	80%
Vol Right, %	33%	10%	22%	13%
Sign Control	Stop	Stop	Stop	Stop
Traffic Vol by Lane	127	92	148	284
LT Vol	5	21	17	19
Through Vol	80	62	99	228
RT Vol	42	9	32	37
Lane Flow Rate	127	92	148	284
Geometry Grp	1	1	1	1
Degree of Util (X)	0.166	0.13	0.202	0.366
Departure Headway (Hd)	4.699	5.095	4.925	4.635
Convergence, Y/N	Yes	Yes	Yes	Yes
Cap	758	698	724	772
Service Time	2.759	3.166	2.99	2.685
HCM Lane V/C Ratio	0.168	0.132	0.204	0.368
HCM Control Delay	8.7	8.9	9.2	10.4
HCM Lane LOS	A	A	A	B
HCM 95th-tile Q	0.6	0.4	0.8	1.7

Intersection												
Int Delay, s/veh	4											
Movement	EBL	EBT	EBR	WBL	WBT	WBR	NBL	NBT	NBR	SBL	SBT	SBR
Lane Configurations		↕			↕			↕			↕	
Traffic Vol, veh/h	9	16	6	13	45	64	10	64	18	27	225	16
Future Vol, veh/h	9	16	6	13	45	64	10	64	18	27	225	16
Conflicting Peds, #/hr	1	0	0	0	0	1	13	0	8	8	0	13
Sign Control	Stop	Stop	Stop	Stop	Stop	Stop	Free	Free	Free	Free	Free	Free
RT Channelized	-	-	None	-	-	None	-	-	None	-	-	None
Storage Length	-	-	-	-	-	-	-	-	-	-	-	-
Veh in Median Storage, #	-	0	-	-	0	-	-	0	-	-	0	-
Grade, %	-	0	-	-	0	-	-	0	-	-	0	-
Peak Hour Factor	100	100	100	100	100	100	100	100	100	100	100	100
Heavy Vehicles, %	1	1	1	1	1	1	1	1	1	1	1	1
Mvmt Flow	9	16	6	13	45	64	10	64	18	27	225	16

Major/Minor	Minor2		Minor1		Major1		Major2					
Conflicting Flow All	449	410	246	399	409	82	254	0	0	90	0	0
Stage 1	300	300	-	101	101	-	-	-	-	-	-	-
Stage 2	149	110	-	298	308	-	-	-	-	-	-	-
Critical Hdwy	7.11	6.51	6.21	7.11	6.51	6.21	4.11	-	-	4.11	-	-
Critical Hdwy Stg 1	6.11	5.51	-	6.11	5.51	-	-	-	-	-	-	-
Critical Hdwy Stg 2	6.11	5.51	-	6.11	5.51	-	-	-	-	-	-	-
Follow-up Hdwy	3.509	4.009	3.309	3.509	4.009	3.309	2.209	-	-	2.209	-	-
Pot Cap-1 Maneuver	522	533	795	563	534	980	1317	-	-	1512	-	-
Stage 1	711	667	-	908	813	-	-	-	-	-	-	-
Stage 2	856	806	-	713	662	-	-	-	-	-	-	-
Platoon blocked, %								-	-	-	-	-
Mov Cap-1 Maneuver	439	507	785	529	508	972	1301	-	-	1500	-	-
Mov Cap-2 Maneuver	439	507	-	529	508	-	-	-	-	-	-	-
Stage 1	697	645	-	893	800	-	-	-	-	-	-	-
Stage 2	748	793	-	676	640	-	-	-	-	-	-	-

Approach	EB		WB		NB		SB	
HCM Control Delay, s	12.4		11.4		0.8		0.7	
HCM LOS	B		B					

Minor Lane/Major Mvmt	NBL	NBT	NBR	EBLn1	WBLn1	SBL	SBT	SBR
Capacity (veh/h)	1301	-	-	519	682	1500	-	-
HCM Lane V/C Ratio	0.008	-	-	0.06	0.179	0.018	-	-
HCM Control Delay (s)	7.8	0	-	12.4	11.4	7.4	0	-
HCM Lane LOS	A	A	-	B	B	A	A	-
HCM 95th %tile Q(veh)	0	-	-	0.2	0.6	0.1	-	-

Intersection						
Int Delay, s/veh	4.8					
Movement	WBL	WBR	NBT	NBR	SBL	SBT
Lane Configurations	↔		↑↓		↔	↑↑
Traffic Vol, veh/h	38	89	1058	19	63	1357
Future Vol, veh/h	38	89	1058	19	63	1357
Conflicting Peds, #/hr	0	0	0	0	0	0
Sign Control	Stop	Stop	Free	Free	Free	Free
RT Channelized	-	None	-	None	-	None
Storage Length	0	-	-	-	50	-
Veh in Median Storage, #	0	-	0	-	-	0
Grade, %	0	-	0	-	-	0
Peak Hour Factor	100	100	100	100	100	100
Heavy Vehicles, %	1	1	1	1	1	1
Mvmt Flow	38	89	1058	19	63	1357

Major/Minor	Minor1	Major1	Major2		
Conflicting Flow All	1873	539	0	0	1077
Stage 1	1068	-	-	-	-
Stage 2	805	-	-	-	-
Critical Hdwy	6.82	6.92	-	-	4.12
Critical Hdwy Stg 1	5.82	-	-	-	-
Critical Hdwy Stg 2	5.82	-	-	-	-
Follow-up Hdwy	3.51	3.31	-	-	2.21
Pot Cap-1 Maneuver	64	489	-	-	649
Stage 1	294	-	-	-	-
Stage 2	403	-	-	-	-
Platoon blocked, %			-	-	-
Mov Cap-1 Maneuver	58	489	-	-	649
Mov Cap-2 Maneuver	58	-	-	-	-
Stage 1	294	-	-	-	-
Stage 2	364	-	-	-	-

Approach	WB	NB	SB
HCM Control Delay, s	93	0	0.5
HCM LOS	F		

Minor Lane/Major Mvmt	NBT	NBRWBLn1	SBL	SBT
Capacity (veh/h)	-	-	152	649
HCM Lane V/C Ratio	-	-	0.836	0.097
HCM Control Delay (s)	-	-	93	11.1
HCM Lane LOS	-	-	F	B
HCM 95th %tile Q(veh)	-	-	5.5	0.3



Intersection						
Int Delay, s/veh	0.7					
Movement	WBL	WBR	NBT	NBR	SBL	SBT
Lane Configurations						
Traffic Vol, veh/h	7	45	1058	12	9	1349
Future Vol, veh/h	7	45	1058	12	9	1349
Conflicting Peds, #/hr	0	0	0	0	4	0
Sign Control	Stop	Stop	Free	Free	Free	Free
RT Channelized	-	None	-	None	-	None
Storage Length	0	-	-	-	-	-
Veh in Median Storage, #	0	-	0	-	-	0
Grade, %	0	-	0	-	-	0
Peak Hour Factor	100	100	100	100	100	100
Heavy Vehicles, %	2	2	2	2	2	2
Mvmt Flow	7	45	1058	12	9	1349

Major/Minor	Minor1	Major1	Major2		
Conflicting Flow All	1761	539	0	0	1074
Stage 1	1068	-	-	-	-
Stage 2	693	-	-	-	-
Critical Hdwy	6.84	6.94	-	-	4.14
Critical Hdwy Stg 1	5.84	-	-	-	-
Critical Hdwy Stg 2	5.84	-	-	-	-
Follow-up Hdwy	3.52	3.32	-	-	2.22
Pot Cap-1 Maneuver	76	487	-	-	645
Stage 1	291	-	-	-	-
Stage 2	457	-	-	-	-
Platoon blocked, %			-	-	-
Mov Cap-1 Maneuver	71	485	-	-	643
Mov Cap-2 Maneuver	71	-	-	-	-
Stage 1	290	-	-	-	-
Stage 2	431	-	-	-	-

Approach	WB	NB	SB
HCM Control Delay, s	21.3	0	0.4
HCM LOS	C		

Minor Lane/Major Mvmt	NBT	NBRWBLn1	SBL	SBT
Capacity (veh/h)	-	-	272	643
HCM Lane V/C Ratio	-	-	0.191	0.014
HCM Control Delay (s)	-	-	21.3	10.7
HCM Lane LOS	-	-	C	B
HCM 95th %tile Q(veh)	-	-	0.7	0

Intersection						
Int Delay, s/veh	0.6					
Movement	EBL	EBR	NBL	NBT	SBT	SBR
Lane Configurations						
Traffic Vol, veh/h	9	9	38	1058	1357	16
Future Vol, veh/h	9	9	38	1058	1357	16
Conflicting Peds, #/hr	0	0	0	0	0	0
Sign Control	Stop	Stop	Free	Free	Free	Free
RT Channelized	-	None	-	None	-	None
Storage Length	0	-	50	-	-	-
Veh in Median Storage, #	0	-	-	0	0	-
Grade, %	0	-	-	0	0	-
Peak Hour Factor	100	100	100	100	100	100
Heavy Vehicles, %	2	2	2	2	2	2
Mvmt Flow	9	9	38	1058	1357	16

Major/Minor	Minor2	Major1	Major2			
Conflicting Flow All	1970	687	1373	0	-	0
Stage 1	1365	-	-	-	-	-
Stage 2	605	-	-	-	-	-
Critical Hdwy	6.84	6.94	4.14	-	-	-
Critical Hdwy Stg 1	5.84	-	-	-	-	-
Critical Hdwy Stg 2	5.84	-	-	-	-	-
Follow-up Hdwy	3.52	3.32	2.22	-	-	-
Pot Cap-1 Maneuver	55	389	496	-	-	-
Stage 1	202	-	-	-	-	-
Stage 2	508	-	-	-	-	-
Platoon blocked, %				-	-	-
Mov Cap-1 Maneuver	51	389	496	-	-	-
Mov Cap-2 Maneuver	51	-	-	-	-	-
Stage 1	186	-	-	-	-	-
Stage 2	508	-	-	-	-	-

Approach	EB	NB	SB
HCM Control Delay, s	54.7	0.4	0
HCM LOS	F		

Minor Lane/Major Mvmt	NBL	NBT	EBLn1	SBT	SBR
Capacity (veh/h)	496	-	90	-	-
HCM Lane V/C Ratio	0.077	-	0.2	-	-
HCM Control Delay (s)	12.9	-	54.7	-	-
HCM Lane LOS	B	-	F	-	-
HCM 95th %tile Q(veh)	0.2	-	0.7	-	-

SC 2 PM  
19: SR 953 & Malaga Avenue

09/22/2021

Intersection						
Int Delay, s/veh	0.6					
Movement	EBL	EBR	NBL	NBT	SBT	SBR
Lane Configurations						
Traffic Vol, veh/h	10	12	24	1058	1349	26
Future Vol, veh/h	10	12	24	1058	1349	26
Conflicting Peds, #/hr	0	4	0	0	0	0
Sign Control	Stop	Stop	Free	Free	Free	Free
RT Channelized	-	None	-	None	-	None
Storage Length	0	-	50	-	-	-
Veh in Median Storage, #	0	-	-	0	0	-
Grade, %	0	-	-	0	0	-
Peak Hour Factor	100	100	100	100	100	100
Heavy Vehicles, %	2	2	2	2	2	2
Mvmt Flow	10	12	24	1058	1349	26

Major/Minor	Minor2	Major1	Major2			
Conflicting Flow All	1939	692	1375	0	-	0
Stage 1	1362	-	-	-	-	-
Stage 2	577	-	-	-	-	-
Critical Hdwy	6.84	6.94	4.14	-	-	-
Critical Hdwy Stg 1	5.84	-	-	-	-	-
Critical Hdwy Stg 2	5.84	-	-	-	-	-
Follow-up Hdwy	3.52	3.32	2.22	-	-	-
Pot Cap-1 Maneuver	57	386	495	-	-	-
Stage 1	203	-	-	-	-	-
Stage 2	525	-	-	-	-	-
Platoon blocked, %				-	-	-
Mov Cap-1 Maneuver	54	385	495	-	-	-
Mov Cap-2 Maneuver	54	-	-	-	-	-
Stage 1	193	-	-	-	-	-
Stage 2	525	-	-	-	-	-

Approach	EB	NB	SB
HCM Control Delay, s	49.7	0.3	0
HCM LOS	E		

Minor Lane/Major Mvmt	NBL	NBT	EBLn1	SBT	SBR
Capacity (veh/h)	495	-	102	-	-
HCM Lane V/C Ratio	0.048	-	0.216	-	-
HCM Control Delay (s)	12.6	-	49.7	-	-
HCM Lane LOS	B	-	E	-	-
HCM 95th %tile Q(veh)	0.2	-	0.8	-	-

## Scenario 3 - AM

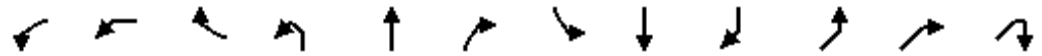
SC 3 AM

3: Salzedo St. & University Dr.

09/22/2021



Movement	EBL	EBT	EBR	WBL	WBT	WBR	NBL	NBT	NBR	SBL	SBT	SBR
Lane Configurations		↕↕			↕↕		↕	↕			↕↕	
Traffic Volume (veh/h)	149	260	0	0	165	9	4	14	16	24	0	72
Future Volume (veh/h)	149	260	0	0	165	9	4	14	16	24	0	72
Initial Q (Qb), veh	0	0	0	0	0	0	0	0	0	0	0	0
Ped-Bike Adj(A_pbT)	0.99		1.00	1.00		0.99	1.00		1.00	1.00		1.00
Parking Bus, Adj	1.00	1.00	1.00	1.00	1.00	1.00	1.00	1.00	1.00	1.00	1.00	1.00
Work Zone On Approach		No			No			No			No	
Adj Sat Flow, veh/h/ln	1885	1885	0	0	1885	1885	1885	1885	1885	1885	1885	1885
Adj Flow Rate, veh/h	149	260	0	0	165	9	4	14	16	24	0	72
Peak Hour Factor	1.00	1.00	1.00	1.00	1.00	1.00	1.00	1.00	1.00	1.00	1.00	1.00
Percent Heavy Veh, %	1	1	0	0	1	1	1	1	1	1	1	1
Cap, veh/h	282	462	0	0	782	42	885	450	514	253	42	656
Arrive On Green	0.23	0.23	0.00	0.00	0.23	0.23	0.56	0.56	0.56	0.56	0.00	0.56
Sat Flow, veh/h	785	2124	0	0	3547	187	1335	801	916	314	75	1168
Grp Volume(v), veh/h	213	196	0	0	85	89	4	0	30	96	0	0
Grp Sat Flow(s),veh/h/ln	1194	1630	0	0	1791	1849	1335	0	1717	1557	0	0
Q Serve(g_s), s	8.0	6.2	0.0	0.0	2.3	2.3	0.0	0.0	0.5	0.0	0.0	0.0
Cycle Q Clear(g_c), s	10.3	6.2	0.0	0.0	2.3	2.3	0.1	0.0	0.5	1.6	0.0	0.0
Prop In Lane	0.70		0.00	0.00		0.10	1.00		0.53	0.25		0.75
Lane Grp Cap(c), veh/h	375	369	0	0	406	419	885	0	964	951	0	0
V/C Ratio(X)	0.57	0.53	0.00	0.00	0.21	0.21	0.00	0.00	0.03	0.10	0.00	0.00
Avail Cap(c_a), veh/h	1223	1389	0	0	1526	1575	885	0	964	951	0	0
HCM Platoon Ratio	1.00	1.00	1.00	1.00	1.00	1.00	1.00	1.00	1.00	1.00	1.00	1.00
Upstream Filter(I)	1.00	1.00	0.00	0.00	1.00	1.00	1.00	0.00	1.00	1.00	0.00	0.00
Uniform Delay (d), s/veh	22.1	19.9	0.0	0.0	18.4	18.4	5.6	0.0	5.7	6.0	0.0	0.0
Incr Delay (d2), s/veh	0.5	0.4	0.0	0.0	0.4	0.4	0.0	0.0	0.1	0.2	0.0	0.0
Initial Q Delay(d3),s/veh	0.0	0.0	0.0	0.0	0.0	0.0	0.0	0.0	0.0	0.0	0.0	0.0
%ile BackOfQ(95%),veh/ln	4.7	4.0	0.0	0.0	1.6	1.7	0.0	0.0	0.3	0.9	0.0	0.0
Unsig. Movement Delay, s/veh												
LnGrp Delay(d),s/veh	22.6	20.3	0.0	0.0	18.7	18.7	5.6	0.0	5.8	6.2	0.0	0.0
LnGrp LOS	C	C	A	A	B	B	A	A	A	A	A	A
Approach Vol, veh/h		409			174			34				96
Approach Delay, s/veh		21.5			18.7			5.8				6.2
Approach LOS		C			B			A				A
Timer - Assigned Phs		2		4		6		8				
Phs Duration (G+Y+Rc), s		39.0		19.4		39.0		19.4				
Change Period (Y+Rc), s		* 6.2		* 6.2		* 6.2		* 6.2				
Max Green Setting (Gmax), s		* 33		* 50		* 33		* 50				
Max Q Clear Time (g_c+I1), s		2.5		12.3		3.6		4.3				
Green Ext Time (p_c), s		0.2		0.9		0.2		1.5				
<b>Intersection Summary</b>												
HCM 6th Ctrl Delay				18.0								
HCM 6th LOS				B								
<b>Notes</b>												
* HCM 6th computational engine requires equal clearance times for the phases crossing the barrier.												



Movement	WBL2	WBL	WBR	NBL	NBT	NBR	SBL	SBT	SBR	NEL	NER	NER2
Lane Configurations												
Traffic Volume (veh/h)	82	145	19	19	1027	103	24	992	207	327	337	13
Future Volume (veh/h)	82	145	19	19	1027	103	24	992	207	327	337	13
Initial Q (Qb), veh	0	0	0	0	0	0	0	0	0	0	0	0
Ped-Bike Adj(A_pbT)	0.99	0.99	0.99	1.00		1.00	1.00		1.00	1.00	1.00	1.00
Parking Bus, Adj	1.00	1.00	1.00	1.00	1.00	1.00	1.00	1.00	1.00	1.00	1.00	1.00
Work Zone On Approach		No			No			No		No		
Adj Sat Flow, veh/h/ln	1870	1870	1870	1870	1870	1870	1870	1870	1870	1870	1870	1870
Adj Flow Rate, veh/h	82	82	19	19	1027	103	24	992	207	327	0	0
Peak Hour Factor	1.00	1.00	1.00	1.00	1.00	1.00	1.00	1.00	1.00	1.00	1.00	1.00
Percent Heavy Veh, %	2	2	2	2	2	2	2	2	2	2	2	2
Cap, veh/h	967	967	70	38	1023	103	38	918	191	466		
Arrive On Green	0.26	0.26	0.33	0.31	0.31	0.31	0.31	0.31	0.31	0.26	0.00	0.00
Sat Flow, veh/h	1781	1781	212	467	3261	327	498	2926	609	1781	0	0
Grp Volume(v), veh/h	82	82	164	19	559	571	24	602	597	327	0	0
Grp Sat Flow(s),veh/h/ln	1781	1781	1830	467	1777	1811	498	1777	1758	1781	0	0
Q Serve(g_s), s	3.7	3.7	12.5	0.0	59.6	59.6	0.0	59.6	59.6	31.5	0.0	0.0
Cycle Q Clear(g_c), s	3.7	3.7	12.5	59.6	59.6	59.6	59.6	59.6	59.6	31.5	0.0	0.0
Prop In Lane	1.00	1.00	0.12	1.00		0.18	1.00		0.35	1.00	0.00	0.00
Lane Grp Cap(c), veh/h	967	967	604	38	557	568	38	557	552	466		
V/C Ratio(X)	0.08	0.08	0.27	0.50	1.00	1.00	0.63	1.08	1.08	0.70		
Avail Cap(c_a), veh/h	967	967	604	38	557	568	38	557	552	466		
HCM Platoon Ratio	1.00	1.00	1.00	1.00	1.00	1.00	1.00	1.00	1.00	1.00	1.00	1.00
Upstream Filter(I)	1.00	1.00	1.00	1.00	1.00	1.00	1.00	1.00	1.00	1.00	0.00	0.00
Uniform Delay (d), s/veh	16.6	16.6	46.8	95.0	65.2	65.2	95.0	65.2	65.2	63.4	0.0	0.0
Incr Delay (d2), s/veh	0.2	0.2	1.1	40.5	39.0	38.9	60.1	61.3	62.7	8.5	0.0	0.0
Initial Q Delay(d3),s/veh	0.0	0.0	0.0	0.0	0.0	0.0	0.0	0.0	0.0	0.0	0.0	0.0
%ile BackOfQ(95%),veh/ln	3.0	3.0	10.1	2.5	42.7	43.4	3.3	49.0	48.8	22.0	0.0	0.0
Unsig. Movement Delay, s/veh												
LnGrp Delay(d),s/veh	16.8	16.8	48.0	135.5	104.2	104.1	155.1	126.5	127.9	72.0	0.0	0.0
LnGrp LOS	B	B	D	F	F	F	F	F	F	E		
Approach Vol, veh/h	246	246			1149			1223		327	A	A
Approach Delay, s/veh	37.6	37.6			104.7			127.8		72.0		
Approach LOS	D	D			F			F		E		
Timer - Assigned Phs		2	3	4		6	7	8				
Phs Duration (G+Y+Rc), s		66.2	55.4	68.4		66.2	55.4	68.4				
Change Period (Y+Rc), s		* 6.6	* 5.7	* 5.7		* 6.6	* 5.7	* 5.7				
Max Green Setting (Gmax), s		* 60	* 50	* 63		* 60	* 50	* 63				
Max Q Clear Time (g_c+I1), s		61.6	5.7	0.0		61.6	33.5	14.5				
Green Ext Time (p_c), s		0.0	0.1	0.0		0.0	0.4	0.2				

Intersection Summary

HCM 6th Ctrl Delay	105.0
HCM 6th LOS	F

Notes

\* HCM 6th computational engine requires equal clearance times for the phases crossing the barrier.  
 Unsignalized Delay for [NER2] is excluded from calculations of the approach delay and intersection delay.

SC 3 AM  
12: Salzedo St. & Catalonia Ave.

09/22/2021

Intersection	
Intersection Delay, s/veh	9.6
Intersection LOS	A

Movement	EBL	EBT	EBR	WBL	WBT	WBR	NBL	NBT	NBR	SBL	SBT	SBR
Lane Configurations		↕			↕			↕			↕	
Traffic Vol, veh/h	50	90	8	8	46	41	8	211	49	14	127	17
Future Vol, veh/h	50	90	8	8	46	41	8	211	49	14	127	17
Peak Hour Factor	1.00	1.00	1.00	1.00	1.00	1.00	1.00	1.00	1.00	1.00	1.00	1.00
Heavy Vehicles, %	2	2	2	2	2	2	2	2	2	2	2	2
Mvmt Flow	50	90	8	8	46	41	8	211	49	14	127	17
Number of Lanes	0	1	0	0	1	0	0	1	0	0	1	0

Approach	EB	WB	NB	SB
Opposing Approach	WB	EB	SB	NB
Opposing Lanes	1	1	1	1
Conflicting Approach Left	SB	NB	EB	WB
Conflicting Lanes Left	1	1	1	1
Conflicting Approach Right	NB	SB	WB	EB
Conflicting Lanes Right	1	1	1	1
HCM Control Delay	9.5	8.7	10.1	9.2
HCM LOS	A	A	B	A

Lane	NBLn1	EBLn1	WBLn1	SBLn1
Vol Left, %	3%	34%	8%	9%
Vol Thru, %	79%	61%	48%	80%
Vol Right, %	18%	5%	43%	11%
Sign Control	Stop	Stop	Stop	Stop
Traffic Vol by Lane	268	148	95	158
LT Vol	8	50	8	14
Through Vol	211	90	46	127
RT Vol	49	8	41	17
Lane Flow Rate	268	148	95	158
Geometry Grp	1	1	1	1
Degree of Util (X)	0.345	0.209	0.129	0.211
Departure Headway (Hd)	4.63	5.089	4.894	4.814
Convergence, Y/N	Yes	Yes	Yes	Yes
Cap	772	700	726	741
Service Time	2.686	3.157	2.968	2.878
HCM Lane V/C Ratio	0.347	0.211	0.131	0.213
HCM Control Delay	10.1	9.5	8.7	9.2
HCM Lane LOS	B	A	A	A
HCM 95th-tile Q	1.5	0.8	0.4	0.8

Intersection												
Int Delay, s/veh	4.1											
Movement	EBL	EBT	EBR	WBL	WBT	WBR	NBL	NBT	NBR	SBL	SBT	SBR
Lane Configurations		↕			↕			↕			↕	
Traffic Vol, veh/h	30	36	7	5	19	45	6	176	13	29	96	7
Future Vol, veh/h	30	36	7	5	19	45	6	176	13	29	96	7
Conflicting Peds, #/hr	2	0	1	1	0	2	2	0	8	8	0	2
Sign Control	Stop	Stop	Stop	Stop	Stop	Stop	Free	Free	Free	Free	Free	Free
RT Channelized	-	-	None	-	-	None	-	-	None	-	-	None
Storage Length	-	-	-	-	-	-	-	-	-	-	-	-
Veh in Median Storage, #	-	0	-	-	0	-	-	0	-	-	0	-
Grade, %	-	0	-	-	0	-	-	0	-	-	0	-
Peak Hour Factor	100	100	100	100	100	100	100	100	100	100	100	100
Heavy Vehicles, %	2	2	2	2	2	2	2	2	2	2	2	2
Mvmt Flow	30	36	7	5	19	45	6	176	13	29	96	7

Major/Minor	Minor2		Minor1		Major1		Major2					
Conflicting Flow All	389	369	103	383	366	193	105	0	0	197	0	0
Stage 1	160	160	-	203	203	-	-	-	-	-	-	-
Stage 2	229	209	-	180	163	-	-	-	-	-	-	-
Critical Hdwy	7.12	6.52	6.22	7.12	6.52	6.22	4.12	-	-	4.12	-	-
Critical Hdwy Stg 1	6.12	5.52	-	6.12	5.52	-	-	-	-	-	-	-
Critical Hdwy Stg 2	6.12	5.52	-	6.12	5.52	-	-	-	-	-	-	-
Follow-up Hdwy	3.518	4.018	3.318	3.518	4.018	3.318	2.218	-	-	2.218	-	-
Pot Cap-1 Maneuver	570	560	952	575	562	849	1486	-	-	1376	-	-
Stage 1	842	766	-	799	733	-	-	-	-	-	-	-
Stage 2	774	729	-	822	763	-	-	-	-	-	-	-
Platoon blocked, %								-	-	-	-	-
Mov Cap-1 Maneuver	512	539	949	526	541	841	1483	-	-	1366	-	-
Mov Cap-2 Maneuver	512	539	-	526	541	-	-	-	-	-	-	-
Stage 1	836	747	-	789	723	-	-	-	-	-	-	-
Stage 2	708	720	-	758	744	-	-	-	-	-	-	-

Approach	EB		WB		NB		SB	
HCM Control Delay, s	12.5		10.7		0.2		1.7	
HCM LOS	B		B					

Minor Lane/Major Mvmt	NBL	NBT	NBR	EBLn1WBLn1	SBL	SBT	SBR
Capacity (veh/h)	1483	-	-	550	703	1366	-
HCM Lane V/C Ratio	0.004	-	-	0.133	0.098	0.021	-
HCM Control Delay (s)	7.4	0	-	12.5	10.7	7.7	0
HCM Lane LOS	A	A	-	B	B	A	A
HCM 95th %tile Q(veh)	0	-	-	0.5	0.3	0.1	-



Intersection						
Int Delay, s/veh	4.1					
Movement	WBL	WBR	NBT	NBR	SBL	SBT
Lane Configurations	↔		↑↓		↔	↑↑
Traffic Vol, veh/h	20	39	1370	32	112	1324
Future Vol, veh/h	20	39	1370	32	112	1324
Conflicting Peds, #/hr	0	0	0	0	0	0
Sign Control	Stop	Stop	Free	Free	Free	Free
RT Channelized	-	None	-	None	-	None
Storage Length	0	-	-	-	50	-
Veh in Median Storage, #	0	-	0	-	-	0
Grade, %	0	-	0	-	-	0
Peak Hour Factor	100	100	100	100	100	100
Heavy Vehicles, %	2	2	2	2	2	2
Mvmt Flow	20	39	1370	32	112	1324

Major/Minor	Minor1	Major1	Major2		
Conflicting Flow All	2272	701	0	0	1402
Stage 1	1386	-	-	-	-
Stage 2	886	-	-	-	-
Critical Hdwy	6.84	6.94	-	-	4.14
Critical Hdwy Stg 1	5.84	-	-	-	-
Critical Hdwy Stg 2	5.84	-	-	-	-
Follow-up Hdwy	3.52	3.32	-	-	2.22
Pot Cap-1 Maneuver	34	381	-	-	483
Stage 1	197	-	-	-	-
Stage 2	363	-	-	-	-
Platoon blocked, %			-	-	-
Mov Cap-1 Maneuver	26	381	-	-	483
Mov Cap-2 Maneuver	26	-	-	-	-
Stage 1	197	-	-	-	-
Stage 2	279	-	-	-	-

Approach	WB	NB	SB
HCM Control Delay, s	175	0	1.1
HCM LOS	F		

Minor Lane/Major Mvmt	NBT	NBRWBLn1	SBL	SBT
Capacity (veh/h)	-	-	68	483
HCM Lane V/C Ratio	-	-	0.868	0.232
HCM Control Delay (s)	-	-	175	14.7
HCM Lane LOS	-	-	F	B
HCM 95th %tile Q(veh)	-	-	4.2	0.9

SC 3 AM  
16: Malaga Ave. & SR 953

09/22/2021

Intersection						
Int Delay, s/veh	3.3					
Movement	WBL	WBR	NBT	NBR	SBL	SBT
Lane Configurations	Y		↑↑			↑↑
Traffic Vol, veh/h	31	27	1296	7	35	1092
Future Vol, veh/h	31	27	1296	7	35	1092
Conflicting Peds, #/hr	0	0	0	0	0	0
Sign Control	Stop	Stop	Free	Free	Free	Free
RT Channelized	-	None	-	None	-	None
Storage Length	0	-	-	-	-	-
Veh in Median Storage, #	0	-	0	-	-	0
Grade, %	0	-	0	-	-	0
Peak Hour Factor	100	100	100	100	100	100
Heavy Vehicles, %	2	2	2	2	2	2
Mvmt Flow	31	27	1296	7	35	1092

Major/Minor	Minor1	Major1	Major2		
Conflicting Flow All	1916	652	0	0	1303
Stage 1	1300	-	-	-	-
Stage 2	616	-	-	-	-
Critical Hdwy	6.84	6.94	-	-	4.14
Critical Hdwy Stg 1	5.84	-	-	-	-
Critical Hdwy Stg 2	5.84	-	-	-	-
Follow-up Hdwy	3.52	3.32	-	-	2.22
Pot Cap-1 Maneuver	59	411	-	-	527
Stage 1	219	-	-	-	-
Stage 2	501	-	-	-	-
Platoon blocked, %			-	-	-
Mov Cap-1 Maneuver	49	411	-	-	527
Mov Cap-2 Maneuver	49	-	-	-	-
Stage 1	219	-	-	-	-
Stage 2	416	-	-	-	-

Approach	WB	NB	SB
HCM Control Delay, s	115.6	0	1.4
HCM LOS	F		

Minor Lane/Major Mvmt	NBT	NBRWBLn1	SBL	SBT
Capacity (veh/h)	-	-	83	527
HCM Lane V/C Ratio	-	-	0.699	0.066
HCM Control Delay (s)	-	-	115.6	12.3
HCM Lane LOS	-	-	F	B
HCM 95th %tile Q(veh)	-	-	3.4	0.2

SC 3 AM  
17: SR 953 & Catalonia Avenue

09/22/2021

Intersection						
Int Delay, s/veh	1.2					
Movement	EBL	EBR	NBL	NBT	SBT	SBR
Lane Configurations						
Traffic Vol, veh/h	17	31	25	1370	1324	6
Future Vol, veh/h	17	31	25	1370	1324	6
Conflicting Peds, #/hr	0	0	0	0	0	0
Sign Control	Stop	Stop	Free	Free	Free	Free
RT Channelized	-	None	-	None	-	None
Storage Length	0	-	50	-	-	-
Veh in Median Storage, #	0	-	-	0	0	-
Grade, %	0	-	-	0	0	-
Peak Hour Factor	100	100	100	100	100	100
Heavy Vehicles, %	2	2	2	2	2	2
Mvmt Flow	17	31	25	1370	1324	6

Major/Minor	Minor2	Major1	Major2			
Conflicting Flow All	2062	665	1330	0	-	0
Stage 1	1327	-	-	-	-	-
Stage 2	735	-	-	-	-	-
Critical Hdwy	6.84	6.94	4.14	-	-	-
Critical Hdwy Stg 1	5.84	-	-	-	-	-
Critical Hdwy Stg 2	5.84	-	-	-	-	-
Follow-up Hdwy	3.52	3.32	2.22	-	-	-
Pot Cap-1 Maneuver	47	403	515	-	-	-
Stage 1	212	-	-	-	-	-
Stage 2	435	-	-	-	-	-
Platoon blocked, %				-	-	-
Mov Cap-1 Maneuver	45	403	515	-	-	-
Mov Cap-2 Maneuver	45	-	-	-	-	-
Stage 1	202	-	-	-	-	-
Stage 2	435	-	-	-	-	-

Approach	EB	NB	SB
HCM Control Delay, s	64.4	0.2	0
HCM LOS	F		

Minor Lane/Major Mvmt	NBL	NBT	EBLn1	SBT	SBR
Capacity (veh/h)	515	-	106	-	-
HCM Lane V/C Ratio	0.049	-	0.453	-	-
HCM Control Delay (s)	12.3	-	64.4	-	-
HCM Lane LOS	B	-	F	-	-
HCM 95th %tile Q(veh)	0.2	-	2	-	-

SC 3 AM  
18: SR 953 & Malaga Avenue

09/22/2021

Intersection						
Int Delay, s/veh	0.4					
Movement	EBL	EBR	NBL	NBT	SBT	SBR
Lane Configurations	↔		↔	↑↑	↑↑	
Traffic Vol, veh/h	11	15	18	1296	1092	13
Future Vol, veh/h	11	15	18	1296	1092	13
Conflicting Peds, #/hr	0	4	1	0	0	1
Sign Control	Stop	Stop	Free	Free	Free	Free
RT Channelized	-	None	-	None	-	None
Storage Length	0	-	50	-	-	-
Veh in Median Storage, #	0	-	-	0	0	-
Grade, %	0	-	-	0	0	-
Peak Hour Factor	100	100	100	100	100	100
Heavy Vehicles, %	2	2	2	2	2	2
Mvmt Flow	11	15	18	1296	1092	13

Major/Minor	Minor2	Major1	Major2			
Conflicting Flow All	1784	558	1106	0	-	0
Stage 1	1100	-	-	-	-	-
Stage 2	684	-	-	-	-	-
Critical Hdwy	6.84	6.94	4.14	-	-	-
Critical Hdwy Stg 1	5.84	-	-	-	-	-
Critical Hdwy Stg 2	5.84	-	-	-	-	-
Follow-up Hdwy	3.52	3.32	2.22	-	-	-
Pot Cap-1 Maneuver	73	473	627	-	-	-
Stage 1	280	-	-	-	-	-
Stage 2	462	-	-	-	-	-
Platoon blocked, %				-	-	-
Mov Cap-1 Maneuver	71	471	626	-	-	-
Mov Cap-2 Maneuver	71	-	-	-	-	-
Stage 1	272	-	-	-	-	-
Stage 2	462	-	-	-	-	-

Approach	EB	NB	SB
HCM Control Delay, s	36.8	0.1	0
HCM LOS	E		

Minor Lane/Major Mvmt	NBL	NBT	EBLn1	SBT	SBR
Capacity (veh/h)	626	-	139	-	-
HCM Lane V/C Ratio	0.029	-	0.187	-	-
HCM Control Delay (s)	10.9	-	36.8	-	-
HCM Lane LOS	B	-	E	-	-
HCM 95th %tile Q(veh)	0.1	-	0.7	-	-

## Scenario 3 - PM

SC 3 PM

3: Salzedo St. & University Dr.

09/22/2021



Lane Group	EBL	EBT	EBR	WBL	WBT	WBR	NBL	NBT	NBR	SBL	SBT	SBR
Lane Configurations		↕↕			↕↕		↕	↕			↕↕	
Traffic Volume (vph)	42	125	0	0	425	9	5	10	10	12	0	224
Future Volume (vph)	42	125	0	0	425	9	5	10	10	12	0	224
Ideal Flow (vphpl)	1900	1900	1900	1900	1900	1900	1900	1900	1900	1900	1900	1900
Lane Util. Factor	0.95	0.95	1.00	1.00	0.95	0.95	1.00	1.00	1.00	1.00	1.00	1.00
Ped Bike Factor		1.00			1.00		1.00	0.99			0.98	
Frt					0.997			0.925			0.872	
Flt Protected		0.988					0.950				0.997	
Satd. Flow (prot)	0	3531	0	0	3561	0	1787	1726	0	0	1608	0
Flt Permitted		0.605					0.612				0.991	
Satd. Flow (perm)	0	2160	0	0	3561	0	1147	1726	0	0	1598	0
Right Turn on Red			Yes			Yes			Yes			Yes
Satd. Flow (RTOR)					2			10			224	
Link Speed (mph)		30			30			30			30	
Link Distance (ft)		777			218			748			279	
Travel Time (s)		17.7			5.0			17.0			6.3	
Confl. Peds. (#/hr)	10		6	6		10	8		6	6		8
Peak Hour Factor	1.00	1.00	1.00	1.00	1.00	1.00	1.00	1.00	1.00	1.00	1.00	1.00
Heavy Vehicles (%)	1%	1%	1%	1%	1%	1%	1%	1%	1%	1%	1%	1%
Adj. Flow (vph)	42	125	0	0	425	9	5	10	10	12	0	224
Shared Lane Traffic (%)												
Lane Group Flow (vph)	0	167	0	0	434	0	5	20	0	0	236	0
Enter Blocked Intersection	No	No	No	No	No	No	No	No	No	No	No	No
Lane Alignment	Left	Left	Right	Left	Left	Right	Left	Left	Right	Left	Left	Right
Median Width(ft)		0			0			12			12	
Link Offset(ft)		0			0			0			0	
Crosswalk Width(ft)		16			16			16			16	
Two way Left Turn Lane												
Headway Factor	1.00	1.00	1.00	1.00	1.00	1.00	1.00	1.00	1.00	1.00	1.00	1.00
Turning Speed (mph)	15		9	15		9	15		9	15		9
Number of Detectors	1	2			2		1	2		1	2	
Detector Template	Left	Thru			Thru		Left	Thru		Left	Thru	
Leading Detector (ft)	20	100			100		20	100		20	100	
Trailing Detector (ft)	0	0			0		0	0		0	0	
Detector 1 Position(ft)	0	0			0		0	0		0	0	
Detector 1 Size(ft)	20	6			6		20	6		20	6	
Detector 1 Type	Cl+Ex	Cl+Ex			Cl+Ex		Cl+Ex	Cl+Ex		Cl+Ex	Cl+Ex	
Detector 1 Channel												
Detector 1 Extend (s)	0.0	0.0			0.0		0.0	0.0		0.0	0.0	
Detector 1 Queue (s)	0.0	0.0			0.0		0.0	0.0		0.0	0.0	
Detector 1 Delay (s)	0.0	0.0			0.0		0.0	0.0		0.0	0.0	
Detector 2 Position(ft)		94			94			94			94	
Detector 2 Size(ft)		6			6			6			6	
Detector 2 Type		Cl+Ex			Cl+Ex			Cl+Ex			Cl+Ex	
Detector 2 Channel												
Detector 2 Extend (s)		0.0			0.0			0.0			0.0	
Turn Type	Perm	NA			NA		Perm	NA		Perm	NA	
Protected Phases		4			8			2			6	
Permitted Phases	4						2			6		

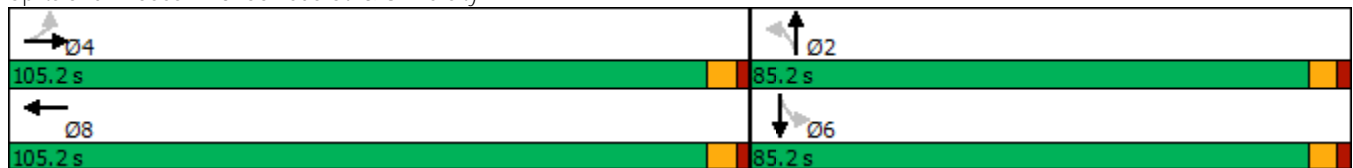


Lane Group	EBL	EBT	EBR	WBL	WBT	WBR	NBL	NBT	NBR	SBL	SBT	SBR
Detector Phase	4	4			8		2	2		6	6	
Switch Phase												
Minimum Initial (s)	12.0	12.0			12.0		7.0	7.0		7.0	7.0	
Minimum Split (s)	24.2	24.2			24.2		24.2	24.2		24.2	24.2	
Total Split (s)	105.2	105.2			105.2		85.2	85.2		85.2	85.2	
Total Split (%)	55.3%	55.3%			55.3%		44.7%	44.7%		44.7%	44.7%	
Maximum Green (s)	99.0	99.0			99.0		79.0	79.0		79.0	79.0	
Yellow Time (s)	4.0	4.0			4.0		4.0	4.0		4.0	4.0	
All-Red Time (s)	2.2	2.2			2.2		2.2	2.2		2.2	2.2	
Lost Time Adjust (s)		0.0			0.0		0.0	0.0			0.0	
Total Lost Time (s)		6.2			6.2		6.2	6.2			6.2	
Lead/Lag												
Lead-Lag Optimize?												
Vehicle Extension (s)	1.0	1.0			1.0		4.0	4.0		4.0	4.0	
Recall Mode	None	None			None		Max	Max		Max	Max	
Act Effct Green (s)		16.4			16.4		79.1	79.1			79.1	
Actuated g/C Ratio		0.15			0.15		0.73	0.73			0.73	
v/c Ratio		0.51			0.80		0.01	0.02			0.19	
Control Delay		47.6			55.6		4.6	3.1			1.2	
Queue Delay		0.0			0.0		0.0	0.0			0.0	
Total Delay		47.6			55.6		4.6	3.1			1.2	
LOS		D			E		A	A			A	
Approach Delay		47.6			55.6			3.4			1.2	
Approach LOS		D			E			A			A	

Intersection Summary

Area Type:	Other
Cycle Length:	190.4
Actuated Cycle Length:	107.9
Natural Cycle:	50
Control Type:	Semi Act-Uncoord
Maximum v/c Ratio:	0.80
Intersection Signal Delay:	37.6
Intersection LOS:	D
Intersection Capacity Utilization	59.5%
ICU Level of Service	B
Analysis Period (min)	15

Splits and Phases: 3: Salzedo St. & University Dr.





Lane Group	EBL	EBT	EBR	WBL	WBT	WBR	NBL	NBT	NBR	SBL	SBT	SBR
Lane Configurations												
Traffic Volume (vph)	156	140	29	280	430	9	66	984	63	26	1001	397
Future Volume (vph)	156	140	29	280	430	9	66	984	63	26	1001	397
Ideal Flow (vphpl)	1900	1900	1900	1900	1900	1900	1900	1900	1900	1900	1900	1900
Storage Length (ft)	160		0	0		0	230		0	110		0
Storage Lanes	1		0	1		0	1		0	1		0
Taper Length (ft)	25			25			25			25		
Lane Util. Factor	1.00	0.95	0.95	1.00	1.00	1.00	1.00	0.95	0.95	1.00	0.95	0.95
Ped Bike Factor	1.00	1.00		1.00	1.00			1.00			0.99	
Frt		0.974			0.997			0.991			0.957	
Flt Protected	0.950			0.950			0.950			0.950		
Satd. Flow (prot)	1770	3438	0	1770	1857	0	1770	3504	0	1770	3365	0
Flt Permitted	0.950			0.636			0.067			0.067		
Satd. Flow (perm)	1766	3438	0	1181	1857	0	125	3504	0	125	3365	0
Right Turn on Red			Yes			Yes			Yes			Yes
Satd. Flow (RTOR)		14			1			4			32	
Link Speed (mph)		30			30			30			30	
Link Distance (ft)		984			777			738			545	
Travel Time (s)		22.4			17.7			16.8			12.4	
Confl. Peds. (#/hr)	2		2	2		2	1		2	2		1
Peak Hour Factor	1.00	1.00	1.00	1.00	1.00	1.00	1.00	1.00	1.00	1.00	1.00	1.00
Adj. Flow (vph)	156	140	29	280	430	9	66	984	63	26	1001	397
Shared Lane Traffic (%)												
Lane Group Flow (vph)	156	169	0	280	439	0	66	1047	0	26	1398	0
Enter Blocked Intersection	No	No	No	No	No	No	No	No	No	No	No	No
Lane Alignment	Left	Left	Right	Left	Left	Right	Left	Left	Right	Left	Left	Right
Median Width(ft)		12			12			12			12	
Link Offset(ft)		0			0			0			0	
Crosswalk Width(ft)		16			16			16			16	
Two way Left Turn Lane												
Headway Factor	1.00	1.00	1.00	1.00	1.00	1.00	1.00	1.00	1.00	1.00	1.00	1.00
Turning Speed (mph)	15		9	15		9	15		9	15		9
Turn Type	Prot	NA		pm+pt	NA		Perm	NA		Perm	NA	
Protected Phases	7	4		3	8			2			6	
Permitted Phases				8			2			6		
Minimum Split (s)	10.7	35.7		10.7	35.7		36.6	36.6		36.6	36.6	
Total Split (s)	55.4	68.4		55.4	68.4		66.2	66.2		66.2	66.2	
Total Split (%)	29.2%	36.0%		29.2%	36.0%		34.8%	34.8%		34.8%	34.8%	
Maximum Green (s)	49.7	62.7		49.7	62.7		59.6	59.6		59.6	59.6	
Yellow Time (s)	3.7	3.7		3.7	3.7		4.4	4.4		4.4	4.4	
All-Red Time (s)	2.0	2.0		2.0	2.0		2.2	2.2		2.2	2.2	
Lost Time Adjust (s)	0.0	0.0		0.0	0.0		0.0	0.0		0.0	0.0	
Total Lost Time (s)	5.7	5.7		5.7	5.7		6.6	6.6		6.6	6.6	
Lead/Lag	Lead	Lag		Lead	Lag							
Lead-Lag Optimize?	Yes	Yes		Yes	Yes							
Walk Time (s)		7.0			7.0		7.0	7.0		7.0	7.0	
Flash Dont Walk (s)		23.0			23.0		23.0	23.0		23.0	23.0	
Pedestrian Calls (#/hr)		0			0		0	0		0	0	
Act Effect Green (s)	49.7	62.7		112.4	62.7		59.6	59.6		59.6	59.6	





Lane Group	EBL	EBT	EBR	WBL	WBT	WBR	NBL	NBT	NBR	SBL	SBT	SBR
Actuated g/C Ratio	0.26	0.33		0.59	0.33		0.31	0.31		0.31	0.31	
v/c Ratio	0.34	0.15		0.33	0.72		1.69	0.95		0.67	1.30	
Control Delay	59.3	41.4		17.5	63.5		436.1	80.5		125.5	189.2	
Queue Delay	0.0	0.0		0.0	2.1		0.0	0.0		0.0	0.0	
Total Delay	59.3	41.4		17.5	65.5		436.1	80.5		125.5	189.2	
LOS	E	D		B	E		F	F		F	F	
Approach Delay		50.0			46.8			101.6			188.0	
Approach LOS		D			D			F			F	

Intersection Summary

Area Type:	Other
Cycle Length:	190
Actuated Cycle Length:	190
Offset:	0 (0%), Referenced to phase 2:NBTL and 6:SBTL, Start of Green
Natural Cycle:	95
Control Type:	Pretimed
Maximum v/c Ratio:	1.69
Intersection Signal Delay:	120.3
Intersection LOS:	F
Intersection Capacity Utilization	107.2%
ICU Level of Service	G
Analysis Period (min)	15

Splits and Phases: 6: SR 953 & University Dr.

 Ø2 (R) 66.2 s	 Ø3 55.4 s	 Ø4 68.4 s
 Ø6 (R) 66.2 s	 Ø7 55.4 s	 Ø8 68.4 s

SC 3 PM

9: Salzedo St. & Malaga Ave.

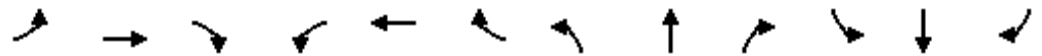
09/22/2021



Lane Group	EBL	EBT	EBR	WBL	WBT	WBR	NBL	NBT	NBR	SBL	SBT	SBR
Lane Configurations		↕			↕			↕			↕	
Traffic Volume (vph)	21	18	7	13	45	66	10	65	18	27	225	16
Future Volume (vph)	21	18	7	13	45	66	10	65	18	27	225	16
Ideal Flow (vphpl)	1900	1900	1900	1900	1900	1900	1900	1900	1900	1900	1900	1900
Lane Util. Factor	1.00	1.00	1.00	1.00	1.00	1.00	1.00	1.00	1.00	1.00	1.00	1.00
Ped Bike Factor												
Frt		0.979			0.928			0.974			0.992	
Flt Protected		0.978			0.995			0.995			0.995	
Satd. Flow (prot)	0	1801	0	0	1737	0	0	1823	0	0	1857	0
Flt Permitted		0.978			0.995			0.995			0.995	
Satd. Flow (perm)	0	1801	0	0	1737	0	0	1823	0	0	1857	0
Link Speed (mph)		30			30			30			30	
Link Distance (ft)		416			346			279			263	
Travel Time (s)		9.5			7.9			6.3			6.0	
Confl. Peds. (#/hr)	1						1	13		8	8	13
Peak Hour Factor	1.00	1.00	1.00	1.00	1.00	1.00	1.00	1.00	1.00	1.00	1.00	1.00
Heavy Vehicles (%)	1%	1%	1%	1%	1%	1%	1%	1%	1%	1%	1%	1%
Adj. Flow (vph)	21	18	7	13	45	66	10	65	18	27	225	16
Shared Lane Traffic (%)												
Lane Group Flow (vph)	0	46	0	0	124	0	0	93	0	0	268	0
Enter Blocked Intersection	No	No	No	No	No	No	No	No	No	No	No	No
Lane Alignment	Left	Left	Right	Left	Left	Right	Left	Left	Right	Left	Left	Right
Median Width(ft)		0			0			0			0	
Link Offset(ft)		0			0			0			0	
Crosswalk Width(ft)		16			16			16			16	
Two way Left Turn Lane												
Headway Factor	1.00	1.00	1.00	1.00	1.00	1.00	1.00	1.00	1.00	1.00	1.00	1.00
Turning Speed (mph)	15		9	15		9	15		9	15		9
Sign Control		Stop			Stop			Free			Free	

Intersection Summary

Area Type:	Other
Control Type:	Unsignalized
Intersection Capacity Utilization	32.9%
ICU Level of Service	A
Analysis Period (min)	15



Lane Group	EBL	EBT	EBR	WBL	WBT	WBR	NBL	NBT	NBR	SBL	SBT	SBR
Lane Configurations		↕			↕			↕			↕	
Traffic Volume (vph)	21	62	9	17	107	32	8	87	47	19	228	48
Future Volume (vph)	21	62	9	17	107	32	8	87	47	19	228	48
Ideal Flow (vphpl)	1900	1900	1900	1900	1900	1900	1900	1900	1900	1900	1900	1900
Storage Length (ft)	150		150	0		0	0		0	0		0
Storage Lanes	0		0	0		0	0		0	0		0
Taper Length (ft)	25			25			25			25		
Lane Util. Factor	1.00	1.00	1.00	1.00	1.00	1.00	1.00	1.00	1.00	1.00	1.00	1.00
Frt		0.987			0.972			0.955			0.978	
Flt Protected		0.989			0.995			0.997			0.997	
Satd. Flow (prot)	0	1801	0	0	1784	0	0	1756	0	0	1799	0
Flt Permitted		0.989			0.995			0.997			0.997	
Satd. Flow (perm)	0	1801	0	0	1784	0	0	1756	0	0	1799	0
Link Speed (mph)		30			30			30			30	
Link Distance (ft)		682			435			263			184	
Travel Time (s)		15.5			9.9			6.0			4.2	
Peak Hour Factor	1.00	1.00	1.00	1.00	1.00	1.00	1.00	1.00	1.00	1.00	1.00	1.00
Heavy Vehicles (%)	3%	3%	3%	3%	3%	3%	3%	3%	3%	3%	3%	3%
Adj. Flow (vph)	21	62	9	17	107	32	8	87	47	19	228	48
Shared Lane Traffic (%)												
Lane Group Flow (vph)	0	92	0	0	156	0	0	142	0	0	295	0
Enter Blocked Intersection	No	No	No	No	No	No	No	No	No	No	No	No
Lane Alignment	Left	Left	Right	Left	Left	Right	Left	Left	Right	Left	Left	Right
Median Width(ft)		0			0			0			0	
Link Offset(ft)		0			0			0			0	
Crosswalk Width(ft)		16			16			16			16	
Two way Left Turn Lane												
Headway Factor	1.00	1.00	1.00	1.00	1.00	1.00	1.00	1.00	1.00	1.00	1.00	1.00
Turning Speed (mph)	15		9	15		9	15		9	15		9
Sign Control		Stop			Stop			Stop			Stop	

Intersection Summary

Area Type:	Other
Control Type:	Unsignalized
Intersection Capacity Utilization	37.4%
ICU Level of Service	A
Analysis Period (min)	15



Lane Group	WBL	WBR	NBT	NBR	SBL	SBT
Lane Configurations						
Traffic Volume (vph)	38	89	1065	44	75	1357
Future Volume (vph)	38	89	1065	44	75	1357
Ideal Flow (vphp)	1900	1900	1900	1900	1900	1900
Storage Length (ft)	0	0		0	50	
Storage Lanes	1	0		0	1	
Taper Length (ft)	25				25	
Lane Util. Factor	1.00	1.00	0.95	0.95	1.00	0.95
Frt	0.905		0.994			
Flt Protected	0.985				0.950	
Satd. Flow (prot)	1677	0	3553	0	1787	3574
Flt Permitted	0.985				0.950	
Satd. Flow (perm)	1677	0	3553	0	1787	3574
Link Speed (mph)	30		30			30
Link Distance (ft)	682		139			144
Travel Time (s)	15.5		3.2			3.3
Peak Hour Factor	1.00	1.00	1.00	1.00	1.00	1.00
Heavy Vehicles (%)	1%	1%	1%	1%	1%	1%
Adj. Flow (vph)	38	89	1065	44	75	1357
Shared Lane Traffic (%)						
Lane Group Flow (vph)	127	0	1109	0	75	1357
Enter Blocked Intersection	No	No	No	No	No	No
Lane Alignment	Left	Right	Left	Right	Left	Left
Median Width(ft)	12		12			12
Link Offset(ft)	0		0			0
Crosswalk Width(ft)	16		16			16
Two way Left Turn Lane						
Headway Factor	1.00	1.00	1.00	1.00	1.00	1.00
Turning Speed (mph)	15	9		9	15	
Sign Control	Stop		Free			Free

Intersection Summary

Area Type:	Other
Control Type:	Unsignalized
Intersection Capacity Utilization	52.6%
Analysis Period (min)	15
	ICU Level of Service A

SC 3 PM  
16: SR 953 & Malaga Ave

09/22/2021



Lane Group	WBL	WBR	NBT	NBR	SBL	SBT
Lane Configurations						
Traffic Volume (vph)	24	52	1083	12	9	1349
Future Volume (vph)	24	52	1083	12	9	1349
Ideal Flow (vphpl)	1900	1900	1900	1900	1900	1900
Lane Util. Factor	1.00	1.00	0.95	0.95	0.95	0.95
Ped Bike Factor						
Frt	0.908		0.998			
Flt Protected	0.984					
Satd. Flow (prot)	1664	0	3532	0	0	3539
Flt Permitted	0.984					
Satd. Flow (perm)	1664	0	3532	0	0	3539
Link Speed (mph)	30		30			30
Link Distance (ft)	244		131			138
Travel Time (s)	5.5		3.0			3.1
Confl. Peds. (#/hr)					4	
Peak Hour Factor	1.00	1.00	1.00	1.00	1.00	1.00
Adj. Flow (vph)	24	52	1083	12	9	1349
Shared Lane Traffic (%)						
Lane Group Flow (vph)	76	0	1095	0	0	1358
Enter Blocked Intersection	No	No	No	No	No	No
Lane Alignment	Left	Right	Left	Right	Left	Left
Median Width(ft)	12		12			12
Link Offset(ft)	0		0			0
Crosswalk Width(ft)	16		16			16
Two way Left Turn Lane						
Headway Factor	1.00	1.00	1.00	1.00	1.00	1.00
Turning Speed (mph)	15	9		9	15	
Sign Control	Stop		Free			Free

Intersection Summary

Area Type:	Other
Control Type:	Unsignalized
Intersection Capacity Utilization	54.8%
Analysis Period (min)	15
	ICU Level of Service A

SC 3 PM  
17: SR 953 & Catalonia Avenue

09/22/2021



Lane Group	EBL	EBR	NBL	NBT	SBT	SBR
Lane Configurations						
Traffic Volume (vph)	9	9	38	1065	1357	16
Future Volume (vph)	9	9	38	1065	1357	16
Ideal Flow (vphp)	1900	1900	1900	1900	1900	1900
Storage Length (ft)	0	0	50			0
Storage Lanes	1	0	1			0
Taper Length (ft)	25		25			
Lane Util. Factor	1.00	1.00	1.00	0.95	0.95	0.95
Frt	0.932				0.998	
Flt Protected	0.976		0.950			
Satd. Flow (prot)	1694	0	1770	3539	3532	0
Flt Permitted	0.976		0.950			
Satd. Flow (perm)	1694	0	1770	3539	3532	0
Link Speed (mph)	30			30	30	
Link Distance (ft)	853			138	139	
Travel Time (s)	19.4			3.1	3.2	
Peak Hour Factor	1.00	1.00	1.00	1.00	1.00	1.00
Adj. Flow (vph)	9	9	38	1065	1357	16
Shared Lane Traffic (%)						
Lane Group Flow (vph)	18	0	38	1065	1373	0
Enter Blocked Intersection	No	No	No	No	No	No
Lane Alignment	Left	Right	Left	Left	Left	Right
Median Width(ft)	12			12	12	
Link Offset(ft)	0			0	0	
Crosswalk Width(ft)	16			16	16	
Two way Left Turn Lane						
Headway Factor	1.00	1.00	1.00	1.00	1.00	1.00
Turning Speed (mph)	15	9	15			9
Sign Control	Stop			Free	Free	

Intersection Summary

Area Type:	Other
Control Type:	Unsignalized
Intersection Capacity Utilization	48.0%
ICU Level of Service	A
Analysis Period (min)	15

SC 3 PM  
19: SR 953 & Malaga Avenue

09/22/2021



Lane Group	EBL	EBR	NBL	NBT	SBT	SBR
Lane Configurations						
Traffic Volume (vph)	10	12	24	1083	1349	26
Future Volume (vph)	10	12	24	1083	1349	26
Ideal Flow (vphp)	1900	1900	1900	1900	1900	1900
Storage Length (ft)	0	0	50			0
Storage Lanes	1	0	1			0
Taper Length (ft)	25		25			
Lane Util. Factor	1.00	1.00	1.00	0.95	0.95	0.95
Ped Bike Factor						
Fr <sub>t</sub>	0.926				0.997	
Fl <sub>t</sub> Protected	0.978		0.950			
Satd. Flow (prot)	1687	0	1770	3539	3529	0
Fl <sub>t</sub> Permitted	0.978		0.950			
Satd. Flow (perm)	1687	0	1770	3539	3529	0
Link Speed (mph)	30			30	30	
Link Distance (ft)	778			545	131	
Travel Time (s)	17.7			12.4	3.0	
Confl. Peds. (#/hr)		4				
Peak Hour Factor	1.00	1.00	1.00	1.00	1.00	1.00
Adj. Flow (vph)	10	12	24	1083	1349	26
Shared Lane Traffic (%)						
Lane Group Flow (vph)	22	0	24	1083	1375	0
Enter Blocked Intersection	No	No	No	No	No	No
Lane Alignment	Left	Right	Left	Left	Left	Right
Median Width(ft)	12			12	12	
Link Offset(ft)	0			0	0	
Crosswalk Width(ft)	16			16	16	
Two way Left Turn Lane						
Headway Factor	1.00	1.00	1.00	1.00	1.00	1.00
Turning Speed (mph)	15	9	15			9
Sign Control	Stop			Free	Free	

Intersection Summary

Area Type:	Other
Control Type:	Unsignalized
Intersection Capacity Utilization	49.4%
ICU Level of Service	A
Analysis Period (min)	15

Intersection	
Intersection Delay, s/veh	9.8
Intersection LOS	A

Movement	EBL	EBT	EBR	WBL	WBT	WBR	NBL	NBT	NBR	SBL	SBT	SBR
Lane Configurations		↕			↕			↕			↕	
Traffic Vol, veh/h	21	62	9	17	107	32	8	87	47	19	228	48
Future Vol, veh/h	21	62	9	17	107	32	8	87	47	19	228	48
Peak Hour Factor	1.00	1.00	1.00	1.00	1.00	1.00	1.00	1.00	1.00	1.00	1.00	1.00
Heavy Vehicles, %	3	3	3	3	3	3	3	3	3	3	3	3
Mvmt Flow	21	62	9	17	107	32	8	87	47	19	228	48
Number of Lanes	0	1	0	0	1	0	0	1	0	0	1	0

Approach	EB	WB	NB	SB
Opposing Approach	WB	EB	SB	NB
Opposing Lanes	1	1	1	1
Conflicting Approach Left	SB	NB	EB	WB
Conflicting Lanes Left	1	1	1	1
Conflicting Approach Right	NB	SB	WB	EB
Conflicting Lanes Right	1	1	1	1
HCM Control Delay	9.1	9.5	8.9	10.6
HCM LOS	A	A	A	B

Lane	NBLn1	EBLn1	WBLn1	SBLn1
Vol Left, %	6%	23%	11%	6%
Vol Thru, %	61%	67%	69%	77%
Vol Right, %	33%	10%	21%	16%
Sign Control	Stop	Stop	Stop	Stop
Traffic Vol by Lane	142	92	156	295
LT Vol	8	21	17	19
Through Vol	87	62	107	228
RT Vol	47	9	32	48
Lane Flow Rate	142	92	156	295
Geometry Grp	1	1	1	1
Degree of Util (X)	0.187	0.132	0.216	0.382
Departure Headway (Hd)	4.743	5.173	4.995	4.661
Convergence, Y/N	Yes	Yes	Yes	Yes
Cap	750	686	713	767
Service Time	2.811	3.253	3.067	2.718
HCM Lane V/C Ratio	0.189	0.134	0.219	0.385
HCM Control Delay	8.9	9.1	9.5	10.6
HCM Lane LOS	A	A	A	B
HCM 95th-tile Q	0.7	0.5	0.8	1.8



Intersection												
Int Delay, s/veh	4.3											
Movement	EBL	EBT	EBR	WBL	WBT	WBR	NBL	NBT	NBR	SBL	SBT	SBR
Lane Configurations		↕			↕			↕			↕	
Traffic Vol, veh/h	21	18	7	13	45	66	10	65	18	27	225	16
Future Vol, veh/h	21	18	7	13	45	66	10	65	18	27	225	16
Conflicting Peds, #/hr	1	0	0	0	0	1	13	0	8	8	0	13
Sign Control	Stop	Stop	Stop	Stop	Stop	Stop	Free	Free	Free	Free	Free	Free
RT Channelized	-	-	None	-	-	None	-	-	None	-	-	None
Storage Length	-	-	-	-	-	-	-	-	-	-	-	-
Veh in Median Storage, #	-	0	-	-	0	-	-	0	-	-	0	-
Grade, %	-	0	-	-	0	-	-	0	-	-	0	-
Peak Hour Factor	100	100	100	100	100	100	100	100	100	100	100	100
Heavy Vehicles, %	1	1	1	1	1	1	1	1	1	1	1	1
Mvmt Flow	21	18	7	13	45	66	10	65	18	27	225	16

Major/Minor	Minor2		Minor1		Major1			Major2				
Conflicting Flow All	451	411	246	402	410	83	254	0	0	91	0	0
Stage 1	300	300	-	102	102	-	-	-	-	-	-	-
Stage 2	151	111	-	300	308	-	-	-	-	-	-	-
Critical Hdwy	7.11	6.51	6.21	7.11	6.51	6.21	4.11	-	-	4.11	-	-
Critical Hdwy Stg 1	6.11	5.51	-	6.11	5.51	-	-	-	-	-	-	-
Critical Hdwy Stg 2	6.11	5.51	-	6.11	5.51	-	-	-	-	-	-	-
Follow-up Hdwy	3.509	4.009	3.309	3.509	4.009	3.309	2.209	-	-	2.209	-	-
Pot Cap-1 Maneuver	520	532	795	561	533	979	1317	-	-	1510	-	-
Stage 1	711	667	-	906	813	-	-	-	-	-	-	-
Stage 2	854	805	-	711	662	-	-	-	-	-	-	-
Platoon blocked, %								-	-	-	-	-
Mov Cap-1 Maneuver	436	506	785	525	507	971	1301	-	-	1498	-	-
Mov Cap-2 Maneuver	436	506	-	525	507	-	-	-	-	-	-	-
Stage 1	697	645	-	892	800	-	-	-	-	-	-	-
Stage 2	744	792	-	671	640	-	-	-	-	-	-	-

Approach	EB		WB		NB		SB	
HCM Control Delay, s	13		11.4		0.8		0.8	
HCM LOS	B		B					

Minor Lane/Major Mvmt	NBL	NBT	NBR	EBLn1	WBLn1	SBL	SBT	SBR
Capacity (veh/h)	1301	-	-	496	683	1498	-	-
HCM Lane V/C Ratio	0.008	-	-	0.093	0.182	0.018	-	-
HCM Control Delay (s)	7.8	0	-	13	11.4	7.4	0	-
HCM Lane LOS	A	A	-	B	B	A	A	-
HCM 95th %tile Q(veh)	0	-	-	0.3	0.7	0.1	-	-

Intersection						
Int Delay, s/veh	5.7					
Movement	WBL	WBR	NBT	NBR	SBL	SBT
Lane Configurations	Y		↑↓		Y	↑↑
Traffic Vol, veh/h	38	89	1065	44	75	1357
Future Vol, veh/h	38	89	1065	44	75	1357
Conflicting Peds, #/hr	0	0	0	0	0	0
Sign Control	Stop	Stop	Free	Free	Free	Free
RT Channelized	-	None	-	None	-	None
Storage Length	0	-	-	-	50	-
Veh in Median Storage, #	0	-	0	-	-	0
Grade, %	0	-	0	-	-	0
Peak Hour Factor	100	100	100	100	100	100
Heavy Vehicles, %	1	1	1	1	1	1
Mvmt Flow	38	89	1065	44	75	1357

Major/Minor	Minor1	Major1	Major2		
Conflicting Flow All	1916	555	0	0	1109
Stage 1	1087	-	-	-	-
Stage 2	829	-	-	-	-
Critical Hdwy	6.82	6.92	-	-	4.12
Critical Hdwy Stg 1	5.82	-	-	-	-
Critical Hdwy Stg 2	5.82	-	-	-	-
Follow-up Hdwy	3.51	3.31	-	-	2.21
Pot Cap-1 Maneuver	60	478	-	-	631
Stage 1	287	-	-	-	-
Stage 2	391	-	-	-	-
Platoon blocked, %			-	-	-
Mov Cap-1 Maneuver	53	478	-	-	631
Mov Cap-2 Maneuver	53	-	-	-	-
Stage 1	287	-	-	-	-
Stage 2	344	-	-	-	-

Approach	WB	NB	SB
HCM Control Delay, s	112.3	0	0.6
HCM LOS	F		

Minor Lane/Major Mvmt	NBT	NBRWBLn1	SBL	SBT
Capacity (veh/h)	-	-	141	631
HCM Lane V/C Ratio	-	-	0.901	0.119
HCM Control Delay (s)	-	-	112.3	11.5
HCM Lane LOS	-	-	F	B
HCM 95th %tile Q(veh)	-	-	6.1	0.4

Intersection						
Int Delay, s/veh	1.5					
Movement	WBL	WBR	NBT	NBR	SBL	SBT
Lane Configurations	T		T		T	
Traffic Vol, veh/h	24	52	1083	12	9	1349
Future Vol, veh/h	24	52	1083	12	9	1349
Conflicting Peds, #/hr	0	0	0	0	4	0
Sign Control	Stop	Stop	Free	Free	Free	Free
RT Channelized	-	None	-	None	-	None
Storage Length	0	-	-	-	-	-
Veh in Median Storage, #	0	-	0	-	-	0
Grade, %	0	-	0	-	-	0
Peak Hour Factor	100	100	100	100	100	100
Heavy Vehicles, %	2	2	2	2	2	2
Mvmt Flow	24	52	1083	12	9	1349

Major/Minor	Minor1	Major1	Major2		
Conflicting Flow All	1786	552	0	0	1099
Stage 1	1093	-	-	-	-
Stage 2	693	-	-	-	-
Critical Hdwy	6.84	6.94	-	-	4.14
Critical Hdwy Stg 1	5.84	-	-	-	-
Critical Hdwy Stg 2	5.84	-	-	-	-
Follow-up Hdwy	3.52	3.32	-	-	2.22
Pot Cap-1 Maneuver	73	477	-	-	631
Stage 1	283	-	-	-	-
Stage 2	457	-	-	-	-
Platoon blocked, %			-	-	-
Mov Cap-1 Maneuver	69	475	-	-	629
Mov Cap-2 Maneuver	69	-	-	-	-
Stage 1	282	-	-	-	-
Stage 2	431	-	-	-	-

Approach	WB	NB	SB
HCM Control Delay, s	43.8	0	0.4
HCM LOS	E		

Minor Lane/Major Mvmt	NBT	NBRWBLn1	SBL	SBT
Capacity (veh/h)	-	-	166	629
HCM Lane V/C Ratio	-	-	0.458	0.014
HCM Control Delay (s)	-	-	43.8	10.8
HCM Lane LOS	-	-	E	B
HCM 95th %tile Q(veh)	-	-	2.1	0

SC 3 PM  
17: SR 953 & Catalonia Avenue

09/22/2021

Intersection						
Int Delay, s/veh	0.6					
Movement	EBL	EBR	NBL	NBT	SBT	SBR
Lane Configurations	W		W	↑↑	↑↑	
Traffic Vol, veh/h	9	9	38	1065	1357	16
Future Vol, veh/h	9	9	38	1065	1357	16
Conflicting Peds, #/hr	0	0	0	0	0	0
Sign Control	Stop	Stop	Free	Free	Free	Free
RT Channelized	-	None	-	None	-	None
Storage Length	0	-	50	-	-	-
Veh in Median Storage, #	0	-	-	0	0	-
Grade, %	0	-	-	0	0	-
Peak Hour Factor	100	100	100	100	100	100
Heavy Vehicles, %	2	2	2	2	2	2
Mvmt Flow	9	9	38	1065	1357	16

Major/Minor	Minor2	Major1	Major2			
Conflicting Flow All	1974	687	1373	0	-	0
Stage 1	1365	-	-	-	-	-
Stage 2	609	-	-	-	-	-
Critical Hdwy	6.84	6.94	4.14	-	-	-
Critical Hdwy Stg 1	5.84	-	-	-	-	-
Critical Hdwy Stg 2	5.84	-	-	-	-	-
Follow-up Hdwy	3.52	3.32	2.22	-	-	-
Pot Cap-1 Maneuver	54	389	496	-	-	-
Stage 1	202	-	-	-	-	-
Stage 2	505	-	-	-	-	-
Platoon blocked, %				-	-	-
Mov Cap-1 Maneuver	50	389	496	-	-	-
Mov Cap-2 Maneuver	50	-	-	-	-	-
Stage 1	186	-	-	-	-	-
Stage 2	505	-	-	-	-	-

Approach	EB	NB	SB
HCM Control Delay, s	55.4	0.4	0
HCM LOS	F		

Minor Lane/Major Mvmt	NBL	NBT	EBLn1	SBT	SBR
Capacity (veh/h)	496	-	89	-	-
HCM Lane V/C Ratio	0.077	-	0.202	-	-
HCM Control Delay (s)	12.9	-	55.4	-	-
HCM Lane LOS	B	-	F	-	-
HCM 95th %tile Q(veh)	0.2	-	0.7	-	-

Intersection						
Int Delay, s/veh	0.6					
Movement	EBL	EBR	NBL	NBT	SBT	SBR
Lane Configurations						
Traffic Vol, veh/h	10	12	24	1083	1349	26
Future Vol, veh/h	10	12	24	1083	1349	26
Conflicting Peds, #/hr	0	4	0	0	0	0
Sign Control	Stop	Stop	Free	Free	Free	Free
RT Channelized	-	None	-	None	-	None
Storage Length	0	-	50	-	-	-
Veh in Median Storage, #	0	-	-	0	0	-
Grade, %	0	-	-	0	0	-
Peak Hour Factor	100	100	100	100	100	100
Heavy Vehicles, %	2	2	2	2	2	2
Mvmt Flow	10	12	24	1083	1349	26

Major/Minor	Minor2	Major1	Major2			
Conflicting Flow All	1952	692	1375	0	-	0
Stage 1	1362	-	-	-	-	-
Stage 2	590	-	-	-	-	-
Critical Hdwy	6.84	6.94	4.14	-	-	-
Critical Hdwy Stg 1	5.84	-	-	-	-	-
Critical Hdwy Stg 2	5.84	-	-	-	-	-
Follow-up Hdwy	3.52	3.32	2.22	-	-	-
Pot Cap-1 Maneuver	56	386	495	-	-	-
Stage 1	203	-	-	-	-	-
Stage 2	517	-	-	-	-	-
Platoon blocked, %				-	-	-
Mov Cap-1 Maneuver	53	385	495	-	-	-
Mov Cap-2 Maneuver	53	-	-	-	-	-
Stage 1	193	-	-	-	-	-
Stage 2	517	-	-	-	-	-

Approach	EB	NB	SB
HCM Control Delay, s	50.9	0.3	0
HCM LOS	F		

Minor Lane/Major Mvmt	NBL	NBT	EBLn1	SBT	SBR
Capacity (veh/h)	495	-	100	-	-
HCM Lane V/C Ratio	0.048	-	0.22	-	-
HCM Control Delay (s)	12.6	-	50.9	-	-
HCM Lane LOS	B	-	F	-	-
HCM 95th %tile Q(veh)	0.2	-	0.8	-	-

## Scenario 3 AM + Signal Retiming

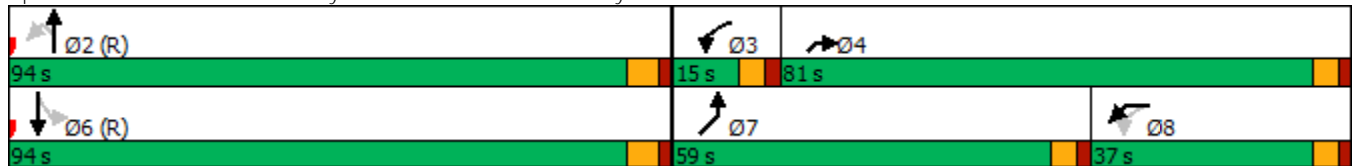


Lane Group	WBL2	WBL	NBL	NBT	SBL	SBT	NEL	NER
Lane Configurations	↖	↖	↖	↑	↖	↑	↖	↖
Traffic Volume (vph)	82	145	19	1027	24	992	327	337
Future Volume (vph)	82	145	19	1027	24	992	327	337
Turn Type	pm+pt	Prot	Perm	NA	Perm	NA	Prot	Prot
Protected Phases	3	8		2		6	7	4
Permitted Phases	8		2		6			
Detector Phase	3	8	2	2	6	6	7	4
Switch Phase								
Minimum Initial (s)	5.0	5.0	7.0	7.0	7.0	7.0	5.0	5.0
Minimum Split (s)	10.7	35.7	36.6	36.6	36.6	36.6	10.7	35.7
Total Split (s)	15.0	37.0	94.0	94.0	94.0	94.0	59.0	81.0
Total Split (%)	7.9%	19.5%	49.5%	49.5%	49.5%	49.5%	31.1%	42.6%
Yellow Time (s)	3.7	3.7	4.4	4.4	4.4	4.4	3.7	3.7
All-Red Time (s)	2.0	2.0	2.2	2.2	2.2	2.2	2.0	2.0
Lost Time Adjust (s)	0.0	0.0	0.0	0.0	0.0	0.0	0.0	0.0
Total Lost Time (s)	5.7	5.7	6.6	6.6	6.6	6.6	5.7	5.7
Lead/Lag	Lead	Lag					Lead	Lag
Lead-Lag Optimize?	Yes	Yes					Yes	Yes
Recall Mode	Max	Max	Max	Max	Max	Max	Max	Max

Intersection Summary

Cycle Length: 190  
 Actuated Cycle Length: 190  
 Offset: 0 (0%), Referenced to phase 2:NBTL and 6:SBTL, Start of Green  
 Natural Cycle: 105  
 Control Type: Pretimed

Splits and Phases: 6: University Drive & SR 953 & University Dr.





Movement	WBL2	WBL	WBR	NBL	NBT	NBR	SBL	SBT	SBR	NEL	NER	NER2
Lane Configurations												
Traffic Volume (veh/h)	82	145	19	19	1027	103	24	992	207	327	337	13
Future Volume (veh/h)	82	145	19	19	1027	103	24	992	207	327	337	13
Initial Q (Qb), veh	0	0	0	0	0	0	0	0	0	0	0	0
Ped-Bike Adj(A_pbT)	0.98	0.98	0.98	1.00		1.00	1.00		1.00	1.00	1.00	1.00
Parking Bus, Adj	1.00	1.00	1.00	1.00	1.00	1.00	1.00	1.00	1.00	1.00	1.00	1.00
Work Zone On Approach		No			No			No		No		
Adj Sat Flow, veh/h/ln	1870	1870	1870	1870	1870	1870	1870	1870	1870	1870	1870	1870
Adj Flow Rate, veh/h	82	82	19	19	1027	103	24	992	207	327	0	0
Peak Hour Factor	1.00	1.00	1.00	1.00	1.00	1.00	1.00	1.00	1.00	1.00	1.00	1.00
Percent Heavy Veh, %	2	2	2	2	2	2	2	2	2	2	2	2
Cap, veh/h	354	354	35	123	1500	150	143	1346	280	500		
Arrive On Green	0.05	0.05	0.16	0.46	0.46	0.46	0.46	0.46	0.46	0.28	0.00	0.00
Sat Flow, veh/h	1781	1781	212	467	3261	327	498	2926	609	1781	0	0
Grp Volume(v), veh/h	82	82	164	19	559	571	24	602	597	327	0	0
Grp Sat Flow(s),veh/h/ln	1781	1781	1828	467	1777	1811	498	1777	1759	1781	0	0
Q Serve(g_s), s	7.2	7.2	15.6	6.6	47.1	47.2	7.6	52.5	52.8	30.7	0.0	0.0
Cycle Q Clear(g_c), s	7.2	7.2	15.6	59.4	47.1	47.2	54.8	52.5	52.8	30.7	0.0	0.0
Prop In Lane	1.00	1.00	0.12	1.00		0.18	1.00		0.35	1.00	0.00	0.00
Lane Grp Cap(c), veh/h	354	354	301	123	817	833	143	817	809	500		
V/C Ratio(X)	0.23	0.23	0.54	0.15	0.68	0.68	0.17	0.74	0.74	0.65		
Avail Cap(c_a), veh/h	354	354	301	123	817	833	143	817	809	500		
HCM Platoon Ratio	1.00	1.00	1.00	1.00	1.00	1.00	1.00	1.00	1.00	1.00	1.00	1.00
Upstream Filter(I)	1.00	1.00	1.00	1.00	1.00	1.00	1.00	1.00	1.00	1.00	0.00	0.00
Uniform Delay (d), s/veh	61.6	61.6	72.8	66.2	40.4	40.4	62.0	41.9	41.9	60.2	0.0	0.0
Incr Delay (d2), s/veh	1.5	1.5	6.9	2.7	4.6	4.6	2.5	5.9	6.0	6.5	0.0	0.0
Initial Q Delay(d3),s/veh	0.0	0.0	0.0	0.0	0.0	0.0	0.0	0.0	0.0	0.0	0.0	0.0
%ile BackOfQ(95%),veh/ln	6.2	6.2	12.6	1.6	29.6	30.1	1.9	32.7	32.6	21.3	0.0	0.0
Unsig. Movement Delay, s/veh												
LnGrp Delay(d),s/veh	63.1	63.1	79.7	68.9	45.1	45.0	64.6	47.7	47.9	66.8	0.0	0.0
LnGrp LOS	E	E	E	E	D	D	E	D	D	E		
Approach Vol, veh/h	246	246			1149			1223		327	A	A
Approach Delay, s/veh	74.2	74.2			45.4			48.2		66.8		
Approach LOS	E	E			D			D		E		
Timer - Assigned Phs		2	3	4		6	7	8				
Phs Duration (G+Y+Rc), s		94.0	15.0	81.0		94.0	59.0	37.0				
Change Period (Y+Rc), s		* 6.6	* 5.7	* 5.7		* 6.6	* 5.7	* 5.7				
Max Green Setting (Gmax), s		* 87	* 9.3	* 75		* 87	* 53	* 31				
Max Q Clear Time (g_c+I1), s		61.4	9.2	0.0		56.8	32.7	17.6				
Green Ext Time (p_c), s		3.0	0.0	0.0		3.4	0.5	0.2				

Intersection Summary

HCM 6th Ctrl Delay	51.3
HCM 6th LOS	D

Notes

\* HCM 6th computational engine requires equal clearance times for the phases crossing the barrier.  
 Unsignalized Delay for [NER2] is excluded from calculations of the approach delay and intersection delay.



## Scenario 3 PM + Signal Retiming

SC-4 PM

6: University Dive & SR 953 & University Dr.

09/28/2021

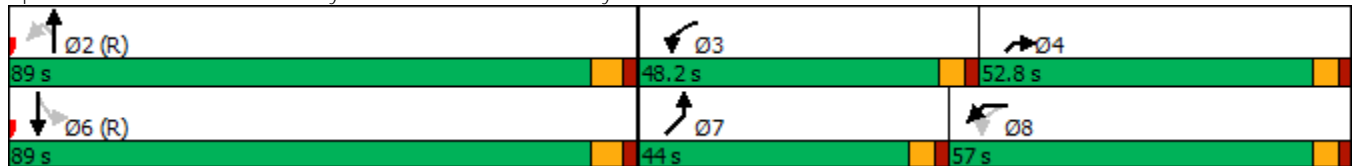


Lane Group	WBL2	WBL	NBL	NBT	SBL	SBT	NEL	NER
Lane Configurations								
Traffic Volume (vph)	280	430	66	984	26	1001	156	140
Future Volume (vph)	280	430	66	984	26	1001	156	140
Turn Type	pm+pt	Prot	Perm	NA	Perm	NA	Prot	Prot
Protected Phases	3	8		2		6	7	4
Permitted Phases	8		2		6			
Detector Phase	3	8	2	2	6	6	7	4
Switch Phase								
Minimum Initial (s)	5.0	5.0	7.0	7.0	7.0	7.0	5.0	5.0
Minimum Split (s)	10.7	35.7	36.6	36.6	36.6	36.6	10.7	35.7
Total Split (s)	48.2	57.0	89.0	89.0	89.0	89.0	44.0	52.8
Total Split (%)	25.4%	30.0%	46.8%	46.8%	46.8%	46.8%	23.2%	27.8%
Yellow Time (s)	3.7	3.7	4.4	4.4	4.4	4.4	3.7	3.7
All-Red Time (s)	2.0	2.0	2.2	2.2	2.2	2.2	2.0	2.0
Lost Time Adjust (s)	0.0	0.0	0.0	0.0	0.0	0.0	0.0	0.0
Total Lost Time (s)	5.7	5.7	6.6	6.6	6.6	6.6	5.7	5.7
Lead/Lag	Lead	Lag					Lead	Lag
Lead-Lag Optimize?	Yes	Yes					Yes	Yes
Recall Mode	Max	Max	Max	Max	Max	Max	Max	Max

Intersection Summary

Cycle Length: 190  
 Actuated Cycle Length: 190  
 Offset: 0 (0%), Referenced to phase 2:NBTL and 6:SBTL, Start of Green  
 Natural Cycle: 95  
 Control Type: Pretimed

Splits and Phases: 6: University Dive & SR 953 & University Dr.





Movement	WBL2	WBL	WBR	NBL	NBT	NBR	SBL	SBT	SBR	NEL	NER	NER2
Lane Configurations												
Traffic Volume (veh/h)	280	430	9	66	984	63	26	1001	397	156	140	29
Future Volume (veh/h)	280	430	9	66	984	63	26	1001	397	156	140	29
Initial Q (Qb), veh	0	0	0	0	0	0	0	0	0	0	0	0
Ped-Bike Adj(A_pbT)	1.00	1.00	1.00	1.00		1.00	1.00		1.00	1.00	1.00	1.00
Parking Bus, Adj	1.00	1.00	1.00	1.00	1.00	1.00	1.00	1.00	1.00	1.00	1.00	1.00
Work Zone On Approach		No			No			No		No		
Adj Sat Flow, veh/h/ln	1870	1870	1870	1870	1870	1870	1870	1870	1870	1870	1870	1870
Adj Flow Rate, veh/h	280	280	9	66	984	63	26	1001	397	156	0	0
Peak Hour Factor	1.00	1.00	1.00	1.00	1.00	1.00	1.00	1.00	1.00	1.00	1.00	1.00
Percent Heavy Veh, %	2	2	2	2	2	2	2	2	2	2	2	2
Cap, veh/h	787	787	10	55	1470	94	147	1081	423	359		
Arrive On Green	0.22	0.22	0.27	0.43	0.43	0.43	0.43	0.43	0.43	0.20	0.00	0.00
Sat Flow, veh/h	1781	1781	38	386	3391	217	539	2493	976	1781	0	0
Grp Volume(v), veh/h	280	280	439	66	516	531	26	710	688	156	0	0
Grp Sat Flow(s),veh/h/ln	1781	1781	1863	386	1777	1831	539	1777	1692	1781	0	0
Q Serve(g_s), s	18.6	18.6	42.7	8.6	44.0	44.0	7.7	71.6	73.8	14.6	0.0	0.0
Cycle Q Clear(g_c), s	18.6	18.6	42.7	82.4	44.0	44.0	51.7	71.6	73.8	14.6	0.0	0.0
Prop In Lane	1.00	1.00	0.02	1.00		0.12	1.00		0.58	1.00	0.00	0.00
Lane Grp Cap(c), veh/h	787	787	503	55	771	794	147	771	734	359		
V/C Ratio(X)	0.36	0.36	0.87	1.19	0.67	0.67	0.18	0.92	0.94	0.43		
Avail Cap(c_a), veh/h	787	787	503	55	771	794	147	771	734	359		
HCM Platoon Ratio	1.00	1.00	1.00	1.00	1.00	1.00	1.00	1.00	1.00	1.00	1.00	1.00
Upstream Filter(I)	1.00	1.00	1.00	1.00	1.00	1.00	1.00	1.00	1.00	1.00	0.00	0.00
Uniform Delay (d), s/veh	31.2	31.2	66.2	93.6	42.9	42.9	63.5	50.7	51.4	66.4	0.0	0.0
Incr Delay (d2), s/veh	1.3	1.3	18.5	182.0	4.6	4.5	2.6	18.1	21.1	3.8	0.0	0.0
Initial Q Delay(d3),s/veh	0.0	0.0	0.0	0.0	0.0	0.0	0.0	0.0	0.0	0.0	0.0	0.0
%ile BackOfQ(95%),veh/ln	13.3	13.3	30.9	10.0	28.0	28.7	2.1	45.6	45.4	11.5	0.0	0.0
Unsig. Movement Delay, s/veh												
LnGrp Delay(d),s/veh	32.4	32.4	84.7	275.7	47.5	47.4	66.2	68.8	72.5	70.2	0.0	0.0
LnGrp LOS	C	C	F	F	D	D	E	E	E	E		
Approach Vol, veh/h	719	719			1113			1424		156	A	A
Approach Delay, s/veh	64.4	64.4			61.0			70.5		70.2		
Approach LOS	E	E			E			E		E		
Timer - Assigned Phs		2	3	4		6	7	8				
Phs Duration (G+Y+Rc), s		89.0	48.2	52.8		89.0	44.0	57.0				
Change Period (Y+Rc), s		* 6.6	* 5.7	* 5.7		* 6.6	* 5.7	* 5.7				
Max Green Setting (Gmax), s		* 82	* 43	* 47		* 82	* 38	* 51				
Max Q Clear Time (g_c+11), s		84.4	20.6	0.0		75.8	16.6	44.7				
Green Ext Time (p_c), s		0.0	0.4	0.0		2.6	0.2	0.4				

Intersection Summary

HCM 6th Ctrl Delay	66.1
HCM 6th LOS	E

Notes

\* HCM 6th computational engine requires equal clearance times for the phases crossing the barrier.  
 Unsignalized Delay for [NER2] is excluded from calculations of the approach delay and intersection delay.

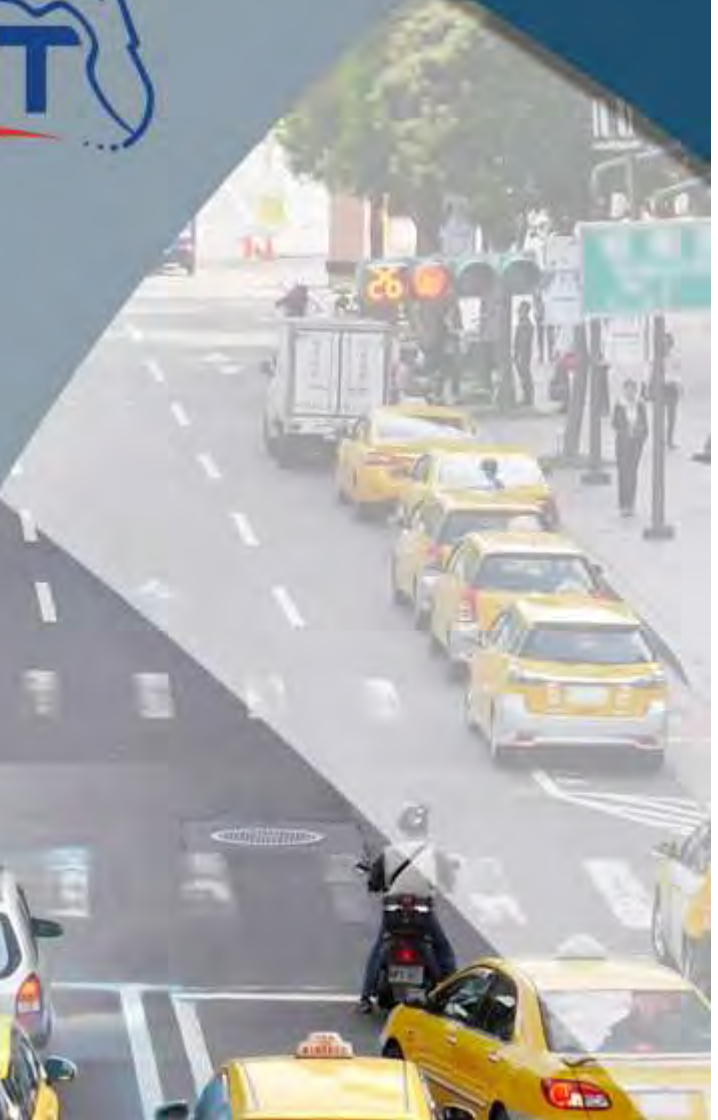
# **Appendix G**

## FDOT QLOS Generalized Tables

# 2020 Quality/ Level of Service Handbook



June 2020



**State of Florida  
Department of Transportation**

*Systems Implementation Office  
605 Suwannee St. MS 19  
Tallahassee, FL 32399*

**[www.fdot.gov/planning](http://www.fdot.gov/planning)**

TABLE 4

Generalized **Peak Hour Two-Way** Volumes for Florida's  
Urbanized Areas<sup>1</sup>

January 2020

INTERRUPTED FLOW FACILITIES						UNINTERRUPTED FLOW FACILITIES					
<b>STATE SIGNALIZED ARTERIALS</b>						<b>FREEWAYS</b>					
<b>Class I (40 mph or higher posted speed limit)</b>						<b>Core Urbanized</b>					
Lanes	Median	B	C	D	E	Lanes	B	C	D	E	
2	Undivided	*	1,510	1,600	**	4	4,050	5,640	6,800	7,420	
4	Divided	*	3,420	3,580	**	6	5,960	8,310	10,220	11,150	
6	Divided	*	5,250	5,390	**	8	7,840	10,960	13,620	14,850	
8	Divided	*	7,090	7,210	**	10	9,800	13,510	17,040	18,580	
						12	11,600	16,350	20,930	23,200	
<b>Class II (35 mph or slower posted speed limit)</b>						<b>Urbanized</b>					
Lanes	Median	B	C	D	E	Lanes	B	C	D	E	
2	Undivided	*	660	1,330	1,410	4	4,130	5,640	7,070	7,690	
4	Divided	*	1,310	2,920	3,040	6	6,200	8,450	10,510	11,530	
6	Divided	*	2,090	4,500	4,590	8	8,270	11,270	13,960	15,380	
8	Divided	*	2,880	6,060	6,130	10	10,350	14,110	17,310	19,220	
<b>Non-State Signalized Roadway Adjustments</b> (Alter corresponding state volumes by the indicated percent.)						<b>Freeway Adjustments</b>					
Non-State Signalized Roadways - 10%						Auxiliary Lanes Present in Both Directions + 1,800					
						Ramp Metering + 5%					
<b>Median &amp; Turn Lane Adjustments</b>						<b>UNINTERRUPTED FLOW HIGHWAYS</b>					
Lanes	Median	Exclusive Left Lanes	Exclusive Right Lanes	Adjustment Factors		Lanes	Median	B	C	D	E
2	Divided	Yes	No	+5%		2	Undivided	1,050	1,620	2,180	2,930
2	Undivided	No	No	-20%		4	Divided	3,270	4,730	5,960	6,780
Multi	Undivided	Yes	No	-5%		6	Divided	4,910	7,090	8,950	10,180
Multi	Undivided	No	No	-25%		<b>Uninterrupted Flow Highway Adjustments</b>					
-	-	-	Yes	+ 5%		Lanes	Median	Exclusive left lanes	Adjustment factors		
<b>One-Way Facility Adjustment</b> Multiply the corresponding two-directional volumes in this table by 0.6						2	Divided	Yes	+5%		
						Multi	Undivided	Yes	-5%		
						Multi	Undivided	No	-25%		
<b>BICYCLE MODE<sup>2</sup></b> (Multiply vehicle volumes shown below by number of directional roadway lanes to determine two-way maximum service volumes.)						<sup>1</sup> Values shown are presented as peak hour directional volumes for levels of service and are for the automobile/truck modes unless specifically stated. This table does not constitute a standard and should be used only for general planning applications. The computer models from which this table is derived should be used for more specific planning applications. The table and deriving computer models should not be used for corridor or intersection design, where more refined techniques exist. Calculations are based on planning applications of the HCM and the Transit Capacity and Quality of Service Manual.					
Paved						<sup>2</sup> Level of service for the bicycle and pedestrian modes in this table is based on number of vehicles, not number of bicyclists or pedestrians using the facility.					
Shoulder/Bicycle						<sup>3</sup> Buses per hour shown are only for the peak hour in the single direction of the higher traffic flow.					
Lane Coverage	B	C	D	E		* Cannot be achieved using table input value defaults.					
0-49%	*	260	680	1,770		** Not applicable for that level of service letter grade. For the automobile mode, volumes greater than level of service D become F because intersection capacities have been reached. For the bicycle mode, the level of service letter grade (including F) is not achievable because there is no maximum vehicle volume threshold using table input value defaults.					
50-84%	190	600	1,770	>1,770		<i>Source:</i> Florida Department of Transportation Systems Implementation Office <a href="https://www.fdot.gov/planning/systems/">https://www.fdot.gov/planning/systems/</a>					
85-100%	830	1,700	>1,770	**							
<b>PEDESTRIAN MODE<sup>2</sup></b> (Multiply vehicle volumes shown below by number of directional roadway lanes to determine two-way maximum service volumes.)											
Sidewalk Coverage	B	C	D	E							
0-49%	*	*	250	850							
50-84%	*	150	780	1,420							
85-100%	340	960	1,560	>1,770							
<b>BUS MODE (Scheduled Fixed Route)<sup>3</sup></b> (Buses in peak hour in peak direction)											
Sidewalk Coverage	B	C	D	E							
0-84%	> 5	≥ 4	≥ 3	≥ 2							
85-100%	> 4	≥ 3	≥ 2	≥ 1							

**TABLE 4**  
(continued)

Generalized **Peak Hour Two-Way** Volumes for Florida's  
Urbanized Areas

January 2020

INPUT VALUE ASSUMPTIONS	Uninterrupted Flow Facilities				Interrupted Flow Facilities					
	Freeways	Core Freeways	Highways		State Arterials			Class I		
					Class I	Class II	Bicycle	Pedestrian		
<b>ROADWAY CHARACTERISTICS</b>										
Area type (urban, rural)	urban	urban								
Number of through lanes (both dir.)	4-10	4-12	2	4-6	2	4-8	2	4-8	4	4
Posted speed (mph)	70	65	50	50	45	50	30	30	45	45
Free flow speed (mph)	75	70	55	55	50	55	35	35	50	50
Auxiliary Lanes (n,y)	n	n								
Median (d, twlt, n, nr, r)				d	n	r	n	r	r	r
Terrain (l,r)	l	l	l	l	l	l	l	l	l	l
% no passing zone			80							
Exclusive left turn lane impact (n, y)			[n]	y	y	y	y	y	y	y
Exclusive right turn lanes (n, y)					n	n	n	n	n	n
Facility length (mi)	3	3	5	5	2	2	1.9	1.8	2	2
<b>TRAFFIC CHARACTERISTICS</b>										
Planning analysis hour factor (K)	0.090	0.085	0.090	0.090	0.090	0.090	0.090	0.090	0.090	0.090
Directional distribution factor (D)	0.55	0.55	0.55	0.55	0.550	0.560	0.565	0.560	0.565	0.565
Peak hour factor (PHF)	0.95	0.95	0.95	0.95	1.000	1.000	1.000	1.000	1.000	1.000
Base saturation flow rate (pcphpl)	2,400	2,400	1,700	2,200	1,950	1,950	1,950	1,950	1,950	1,950
Heavy vehicle percent	4.0	4.0	2.0	2.0	1.0	1.0	1.0	1.0	2.5	2.0
Speed Adjustment Factor (SAF)	0.975	0.975		0.975						
Capacity Adjustment Factor (CAF)	0.968	0.968		0.968						
% left turns					12	12	12	12	12	12
% right turns					12	12	12	12	12	12
<b>CONTROL CHARACTERISTICS</b>										
Number of signals					4	4	10	10	4	6
Arrival type (1-6)					3	3	4	4	4	4
Signal type (a, c, p)					c	c	c	c	c	c
Cycle length (C)					120	150	120	120	120	120
Effective green ratio (g/C)					0.44	0.45	0.44	0.44	0.44	0.44
<b>MULTIMODAL CHARACTERISTICS</b>										
Paved shoulder/bicycle lane (n, y)									n, 50%, y	n
Outside lane width (n, t, w)									t	t
Pavement condition (d, t, u)									t	
On-street parking (n, y)										
Sidewalk (n, y)										n, 50%, y
Sidewalk/roadway separation(a, t, w)										t
Sidewalk protective barrier (n, y)										n
<b>LEVEL OF SERVICE THRESHOLDS</b>										
Level of Service	Freeways	Highways		Arterials		Bicycle	Ped	Bus		
	Density	Two-Lane	Multilane	Class I	Class II	Score	Score	Buses/hr.		
		%ffs	Density						ats	ats
B	≤ 17	> 83.3	≤ 17	> 31 mph	> 22 mph	≤ 2.75	≤ 2.75	≤ 6		
C	≤ 24	> 75.0	≤ 24	> 23 mph	> 17 mph	≤ 3.50	≤ 3.50	≤ 4		
D	≤ 31	> 66.7	≤ 31	> 18 mph	> 13 mph	≤ 4.25	≤ 4.25	< 3		
E	≤ 39	> 58.3	≤ 35	> 15 mph	> 10 mph	≤ 5.00	≤ 5.00	< 2		

% ffs = Percent free flow speed ats = Average travel speed

# **Appendix H**

## **Preliminary Signal Warrants**



# TRAFFIC SIGNAL WARRANT SUMMARY

City: **Coral Gables**  
County: \_\_\_\_\_  
District: \_\_\_\_\_

Engineer: **CALTRAN**  
Date: **September 20, 2021**

Major Street: **Salzedo** Lanes: **1** Major Approach Speed: **30**  
Minor Street: **Catalonia** Lanes: **1** Minor Approach Speed: **30**

MUTCD Electronic Reference to Chapter 4: <http://mutcd.fhwa.dot.gov/pdfs/2009r1r2/part4.pdf>

### Volume Level Criteria

- Is the posted speed or 85th-percentile of major street > 40 mph?  Yes  No
  - Is the intersection in a built-up area of an isolated community with a population < 10,000?  Yes  No
- "70%" volume level **may** be used if Question 1 or 2 above is answered "Yes"  MAY  70%  100%

### WARRANT 2 - FOUR-HOUR VEHICULAR VOLUME

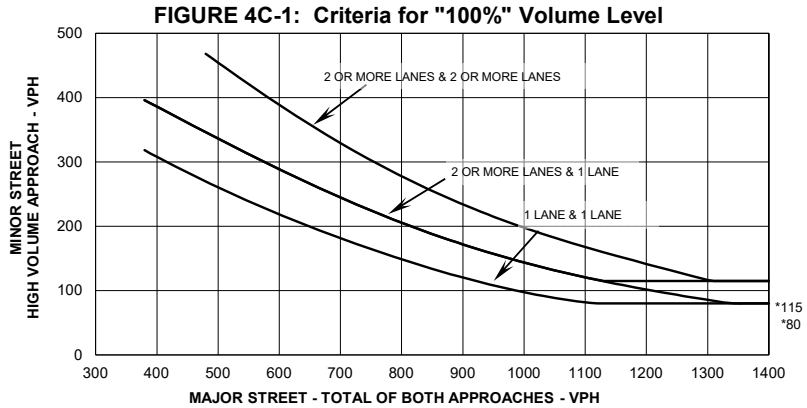
If all four points lie above the appropriate line, then the warrant is satisfied.

Applicable:  Yes  No  
Satisfied:  Yes  No

Plot four volume combinations on the applicable figure below.

#### 100% Volume Level

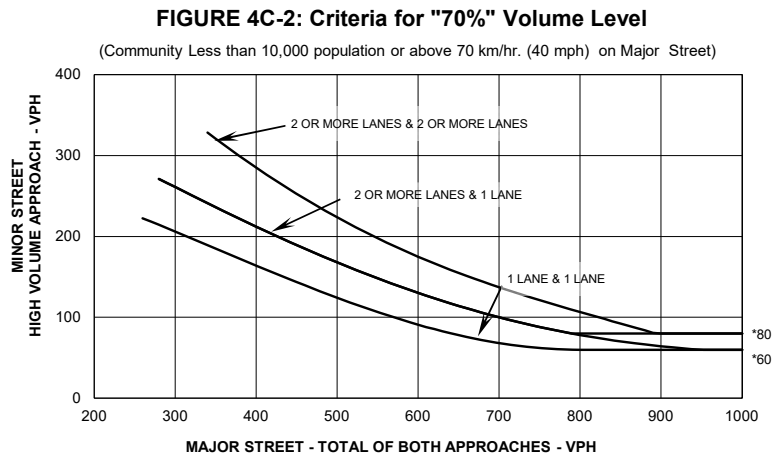
Four Highest Hours	Volumes	
	Major Street	Minor Street
7:00 - 8:00 AM	169	66
8:00 - 9:00 AM	294	118
4:00 - 5:00 PM	281	95
5:00 - 6:00 PM	288	96



\* Note: 115 ph. applies as the lower threshold volume for a minor street approach with two or more lanes and 80 mph applies as the lower threshold volume threshold for a minor street approach with one lane.

#### 70% Volume Level

Four Highest Hours	Volumes	
	Major Street	Minor Street



\* Note: 80 ph. applies as the lower threshold volume for a minor street approach with two or more lanes and 60 ph. applies as the lower threshold volume threshold for a minor street approach with one lane.

# TRAFFIC SIGNAL WARRANT SUMMARY

City: **Coral Gables**  
County: \_\_\_\_\_  
District: \_\_\_\_\_

Engineer: **CALTRAN**  
Date: **September 20, 2021**

Major Street: **Salzedo**  
Minor Street: **Catalonia**

Lanes: **1** Major Approach Speed: **30**  
Lanes: **1** Minor Approach Speed: **30**

MUTCD Electronic Reference to Chapter 4: <http://mutcd.fhwa.dot.gov/pdfs/2009r1r2/part4.pdf>

## WARRANT 7 - CRASH EXPERIENCE

Record hours where criteria are fulfilled, the corresponding volume, and other information in the boxes provided. The warrant is satisfied if **all three** of the criteria are fulfilled.

Applicable:  Yes  No  
Satisfied:  Yes  No

Criteria				Fulfilled?	
				Yes	No
1. Adequate trial of other remedial measure has failed to reduce crash frequency.	Measure tried:	N/A - Currently All-Way Stop-Controlled			X
2. Five or more reported crashes, of types susceptible to correction by signal, have occurred within a 12-month period.	Observed Crash Types:	Angle	Number of crashes per 12 months: 3		X
3. <b>One of the following volume warrants is met:</b>				<b>Met?</b>	
Warrant 1, Condition A (80% satisfied), or				No	
Warrant 1, Condition B (80% satisfied), or				No	
Warrant 4, Pedestrian Volume satisfied at 80% of volume requirements for any 8 hours of an average day.				<b>Hour</b> <b>Major Street Volume</b> <b>Ped Crossings Volume</b>	
				No	

