



[DBPR HOME](#) | [ABOUT DBPR](#) | [DBPR DIVISIONS](#) | [CONTACT DBPR](#)

[BCIS Home](#) | [Log In](#) | [User Registration](#) | [Hot Topics](#) | [Submit Surcharge](#) | [Stats & Facts](#) | [Publications](#) | [Contact Us](#) | [BCIS Site Map](#) | [Links](#) | [Search](#)



Product Approval
USER: Public User

[Product Approval Menu](#) > [Product or Application Search](#) > [Application List](#) > **Application Detail**

OFFICE OF THE SECRETARY

FL #	FL40673-R3
Application Type	Revision
Code Version	2023
Application Status	Approved

Comments

Archived

Product Manufacturer	Mr-Glass Doors & Windows Manufacturing, LLC
Address/Phone/Email	8051 NW 79th Place Medley, FL 33166 (305) 470-8284 ulises@mrglasswindows.com

Authorized Signature: Ulises Senaris
ulises@mrglasswindows.com

Technical Representative: Augusto Arias
Address/Phone/Email: 8120 NW 84th St
Medley, FL 33166
(305) 470-8284
aarias@mrglasswindows.com

Quality Assurance Representative
Address/Phone/Email

Category	Windows
Subcategory	Mullions

Compliance Method: Evaluation Report from a Florida Registered Architect or a Licensed Florida Professional Engineer
 Evaluation Report - Hardcopy Received

Florida Engineer or Architect Name who developed the Evaluation Report: Jalal Farooq
Florida License: PE-81223
Quality Assurance Entity: Keystone Certifications, Inc.
Quality Assurance Contract Expiration Date: 08/27/2025
Validated By: Abel Carrasco, PE
 Validation Checklist - Hardcopy Received

Certificate of Independence	FL40673 R3 COI SS - Certificate of Independence 2022.pdf
-----------------------------	--

Referenced Standard and Year (of Standard)	Standard	Year
	TAS 201	1994
	TAS 202	1994
	TAS 203	1994

Equivalence of Product Standards Certified By

Sections from the Code

Product Approval Method Method 1 Option D

Date Submitted 07/25/2023
 Date Validated 07/25/2023
 Date Pending FBC Approval 08/02/2023
 Date Approved 10/18/2023

Summary of Products

FL #	Model, Number or Name	Description
40673.1	Extruded Aluminum Clipped Mullions	Large missile impact resistant clipped aluminum tube mullions.
Limits of Use Approved for use in HVHZ: Yes Approved for use outside HVHZ: Yes Impact Resistant: Yes Design Pressure: +150/-150 Other: See drawing 21-75F for span vs load combination and installation details.		Installation Instructions FL40673_R3_II_SS - Alum Clipped Mullions DWG 21-75F 2023.pdf Verified By: Jalal Farooq PE # 81223 Created by Independent Third Party: Yes Evaluation Reports FL40673_R3_AE_SS - Clipped Tube Mullion (LMI) - PAE 2023.pdf Created by Independent Third Party: Yes
40673.2	Series MG150 Extruded Aluminum Unclipped Mullions	Large missile impact resistant extruded aluminum unclipped mullions.
Limits of Use Approved for use in HVHZ: Yes Approved for use outside HVHZ: Yes Impact Resistant: Yes Design Pressure: +90/-120 Other: See drawing 22-08F for span vs load combination and installation details.		Installation Instructions FL40673_R3_II_SS - Alum Un-clipped Mullions DWG 22-08F 2023.pdf Verified By: Jalal Farooq PE # 81223 Created by Independent Third Party: Yes Evaluation Reports FL40673_R3_AE_SS - Unclipped Tube Mullion (LMI) - PAE 2023.pdf Created by Independent Third Party: Yes

[Back](#) [Next](#)

Contact Us :: [2601 Blair Stone Road, Tallahassee FL 32399](#) Phone: 850-487-1824

The State of Florida is an AA/EEO employer. Copyright 2007-2013 State of Florida. :: [Privacy Statement](#) :: [Accessibility Statement](#) :: [Refund Statement](#)

Under Florida law, email addresses are public records. If you do not want your e-mail address released in response to a public-records request, do not send electronic mail to this entity. Instead, contact the office by phone or by traditional mail. If you have any questions, please contact 850.487.1395. *Pursuant to Section 455.275(1), Florida Statutes, effective October 1, 2012, licensees licensed under Chapter 455, F.S. must provide the Department with an email address if they have one. The emails provided may be used for official communication with the licensee. However email addresses are public record. If you do not wish to supply a personal address, please provide the Department with an email address which can be made available to the public. To determine if you are a licensee under Chapter 455, F.S., please click [here](#).

Product Approval Accepts:



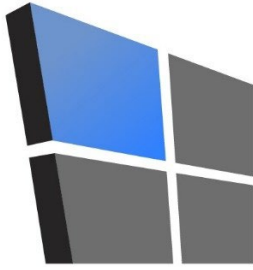

AL-FAROOQ CORPORATION

CONSULTING ENGINEERS & PRODUCT DEVELOPMENT

August 26, 2022

Product Approval Administrator
Building Codes & Standards Section
Department of Business & Professional Regulations
1940 North Monroe Street, Suite 90
Tallahassee, FL 32399-2100

To whom it may concern,

As the design engineer retained to prepare the product approval(s) associated with this letter as shown below on this same web page, I do hereby declare that I do not have and will not have any financial interest in any company manufacturing or distributing the referenced product(s), nor do I have or will have any financial interest with any other entity involved in the approval process of the referenced product(s).

Sincerely,



Sealed: 8/26/2022

Jalal Farooq, P.E.
CFO

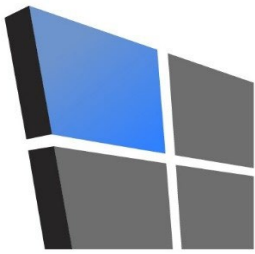

AL-FAROOQ CORPORATION

CONSULTING ENGINEERS & PRODUCT DEVELOPMENT

PRODUCT APPROVAL EVALUATION RULE CHAPTER #61G20-3 • METHOD 1 OPTION D

FL 40673

Date: 07/20/2023

Detailed Product Description:

Manufacturer: MR-GLASS DOORS & WINDOWS MANUFACTURING, LLC

Manufacturer Address: 8051 N.W. 79TH PLACE. MEDLEY, FL 33166

Model Name: EXTRUDED ALUMINUM CLIPPED MULLIONS

Maximum Load: +150 PSF, -150 PSF (Large Missile Impact)

Installation Drawings # 21-75F

This product complies with the High Velocity Hurricane Zone (HVHZ) testing requirements.					
For maximum sizes, combination of span vs loads and anchor type refer to installation drawings.					
Comparative analysis used <input type="checkbox"/> Yes <input checked="" type="checkbox"/> No					
Mandatory Tests (Tested in accordance with ANSI/AAMA 101/I.S.2/NAFS/TAS 202)					
Test	Description	Test Location	Test Report Date	Test Report #	Test Sealed By
ASTM E330 & TAS 202	Uniform Static Air Pressure	Hurricane Engineering & Testing, Inc	12/10/2021 12/10/2021	HETI-21-7111 HETI-21-7126	Dr. Ram Tewari, PE
Supplemental Tests (Tested in accordance with TAS-201 and TAS-203)					
Test	Description	Test Location	Test Report Date	Test Report#	Test Sealed By
FBC 1626.2 (TAS 201 & 203) ASTM E1886/1996	Large Missile Impact & Cyclic	Hurricane Engineering & Testing, Inc	12/10/2021 12/10/2021	HETI-21-7111 HETI-21-7126	Dr. Ram Tewari, PE
Under the limitations of the attached installation drawings, to the best of my knowledge and ability, the above product conforms to the requirements of the 2023 Florida Building Code.					

Evaluation Report Engineer:

Jalal Farooq
Al-Farooq Corporation

PE # 81223
EB # 3538



Sealed: 7/21/2023

INSTRUCTIONS:

USE CHARTS AND GRAPHS AS FOLLOWS.

- STEP 1** DETERMINE DESIGN LOAD REQUIRED PER ASCE 7 FOR PARTICULAR OPENING.
- STEP 2** USE F.B.C. APPROVED GLAZING PRODUCTS MEETING ABOVE LOAD REQUIREMENTS.
- STEP 3** USE GLAZING PRODUCT CONNECTION TO MULLION AS PER PRODUCT APPROVAL.
- STEP 4** USING CHARTS ON SHEET 3 SELECT MULLION SIZE WITH DESIGN RATING MORE THAN DESIGN LOAD SPECIFIED IN STEP 1 ABOVE.
- STEP 5** USING ANCHOR TYPES AND ANCHOR CAPACITY CHARTS ON SHEETS 4 THRU 17, SELECT ANCHOR TYPE WITH DESIGN RATING MORE THAN THE DESIGN LOADS SPECIFIED IN STEP 1 ABOVE.

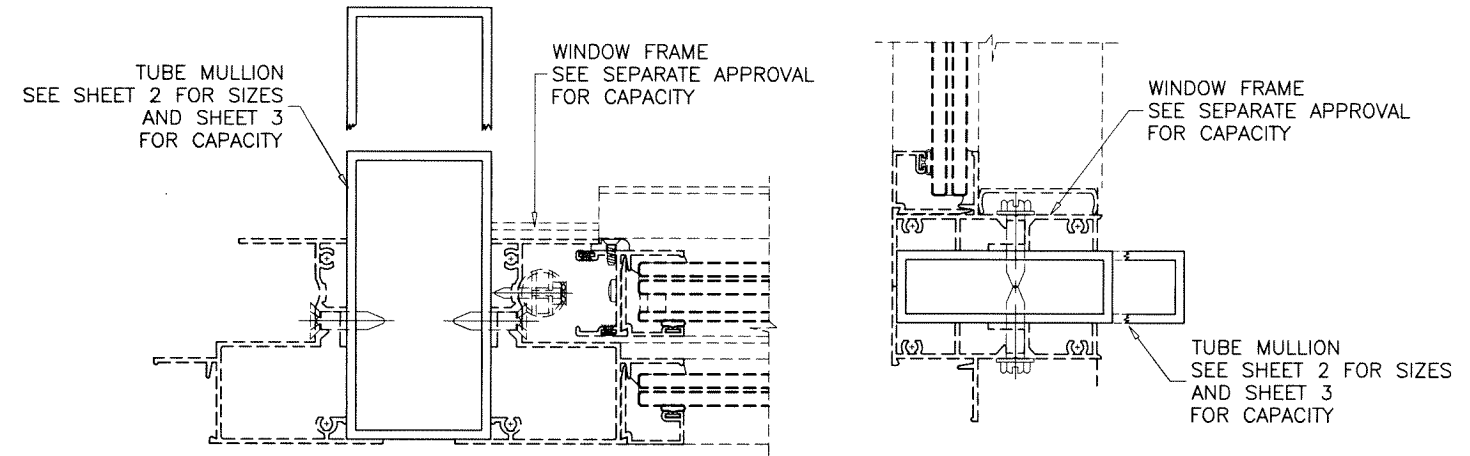

**MULLIONS CONTAINING TYPICAL GLAZING PRODUCTS
HORIZONTAL OR VERTICAL**

SEE WINDOW OR DOOR APPROVAL FOR FASTENERS SIZES AND SPACING

**EXTRUDED ALUMINUM CLIPPED MULLIONS
USING MULLION PROPERTIES ONLY**

MULLION SYSTEM IS RATED FOR LARGE & SMALL MISSILE IMPACT. SEE SEPARATE APPROVAL'S FOR WINDOWS/DOORS IMPACT AND LOAD RATINGS. LOWER VALUES FROM MULLION APPROVAL OR WINDOW/DOOR APPROVAL WILL APPLY TO ENTIRE SYSTEM.

THIS PRODUCT HAS BEEN DESIGNED AND TESTED TO COMPLY WITH THE REQUIREMENTS OF THE 2020 (7TH EDITION)/2023 (8TH EDITION) FLORIDA BUILDING CODE INCLUDING HIGH VELOCITY HURRICANE ZONE (HVHZ).

ALL GLAZING PRODUCTS USED WITH THESE MULLIONS MUST MEET THE APPLICABLE BUILDING CODE REQUIREMENTS I.E: WIND LOAD, WATER INFILTRATION, FORCED ENTRY RESISTANCE, SAFEGUARDS ETC.

1BY OR 2BY WOOD BUCKS & BUCK FASTENERS BY OTHERS, MUST BE DESIGNED AND INSTALLED ADEQUATELY TO TRANSFER APPLIED PRODUCT LOADS TO THE BUILDING STRUCTURE.

ANCHORS SHALL BE CORROSION RESISTANT, SPACED AS SHOWN ON DETAILS AND INSTALLED PER MANUF'S INSTRUCTIONS. SPECIFIED EMBEDMENT TO BASE MATERIAL SHALL BE BEYOND WALL DRESSING OR STUCCO.

A LOAD DURATION INCREASE IS USED IN DESIGN OF ANCHORS INTO WOOD ONLY.

ALL SHIMS TO BE HIGH IMPACT, NON-METALLIC AND NON-COMPRESSIBLE.

MATERIALS INCLUDING BUT NOT LIMITED TO STEEL/METAL SCREWS, THAT COME INTO CONTACT WITH OTHER DISSIMILAR MATERIALS SHALL MEET THE REQUIREMENTS OF THE 2020/2023 FLORIDA BLDG. CODE & ADOPTED STANDARDS.

THIS PRODUCT APPROVAL IS GENERIC AND DOES NOT PROVIDE INFORMATION FOR A SITE SPECIFIC PROJECT, i.e. LIFE SAFETY OF THIS PRODUCT, ADEQUACY OF STRUCTURE RECEIVING THIS PRODUCT AND SEALING AROUND OPENING FOR WATER INFILTRATION RESISTANCE ETC.

CONDITIONS NOT SHOWN IN THIS DRAWING ARE TO BE ANALYZED SEPARATELY, AND TO BE REVIEWED BY BUILDING OFFICIAL.

DESIGN LOADS SHOWN ARE BASED ON 'ALLOWABLE STRESS DESIGN (ASD)'. MANUFACTURER'S LABEL SHALL BE LOCATED ON A READILY VISIBLE LOCATION IN ACCORDANCE WITH SECTION 1709.9.3 OF FLORIDA BUILDING CODE. LABELING TO COMPLY WITH SECTION 1709.9.2.

Sealed: 7/21/2023 FL #40673

- A- CONTRACTOR TO BE RESPONSIBLE FOR THE SELECTION, PURCHASE AND INSTALLATION OF THIS PRODUCT BASED ON THIS PRODUCT EVALUATION PROVIDED HE/SHE DOES NOT DEVIATE FROM THE CONDITIONS DETAILED ON THIS DOCUMENT.
- B- THIS PRODUCT EVALUATION DOCUMENT WILL BE CONSIDERED INVALID IF ALTERED BY ANY MEANS.
- C- SITE SPECIFIC PROJECTS SHALL BE PREPARED BY A FLORIDA REGISTERED ENGINEER OR ARCHITECT WHICH WILL BECOME THE ENGINEER OF RECORD (E.O.R.) FOR THE PROJECT AND WHO WILL BE RESPONSIBLE FOR THE PROPER USE OF THE P.E.D. ENGINEER OF RECORD, ACTING AS A DELEGATED ENGINEER TO THE P.E.D. ENGINEER SHALL SUBMIT TO THIS LATTER THE SITE SPECIFIC DRAWINGS FOR REVIEW.
- D- THIS P.E.D. SHALL BEAR THE DATE AND ORIGINAL SEAL AND SIGNATURE OF THE PROFESSIONAL ENGINEER OF RECORD THAT PREPARED IT.

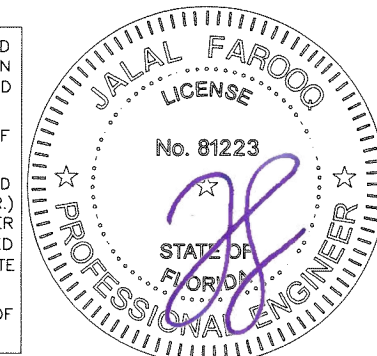

afc
AL-FAROOQ CORPORATION
 ENGINEERS & PRODUCT DEVELOPMENT
 9360 SUNSET DRIVE, SUITE 220
 MIAMI, FLORIDA 33173
 TEL. (305) 264-8100
 WWW.AFCENG.COM
 FBPE #5538
 MULLION\21-75F-MG

EXTRUDED ALUMINUM CLIPPED MULLIONS
MR-GLASS DOORS & WINDOWS MANUFACTURING, LLC
 8051 N.W. 79th Place
 Medley, FL. 33166
 Tel. (305) 764-3963
 www.mrglasswindows.com

no.	date	description	by
A	09.27.22	'F' CLIP ADDED	
B	07.18.23	UPDATED TO 2023 FBC	

date: 12-21-21
 scale: 3/8" = 1"
 dr. by: TARIQ
 chk. by:

drawing no.
21-75F
 sheet 1 of 17

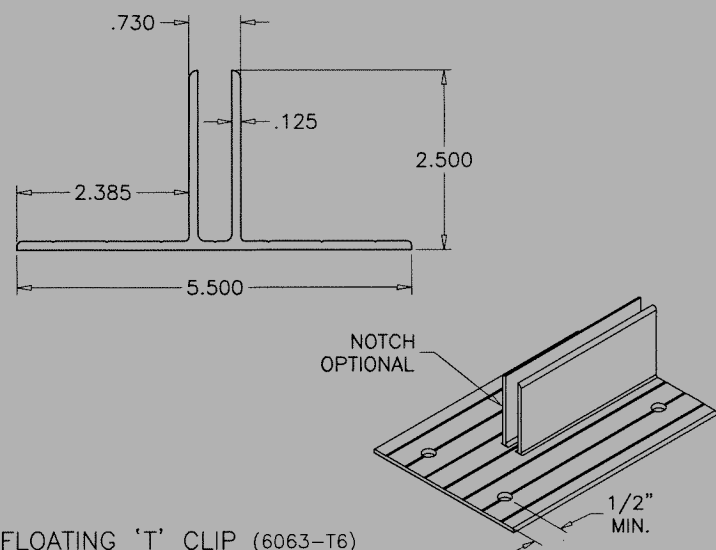

FLOATING 'T' CLIP (6063-T6)
(ALT. TO ANGLES)

CLIP LENGTHS MUST BE CUT TO FIT SNUG INTO 1BY TUBE MULLIONS.

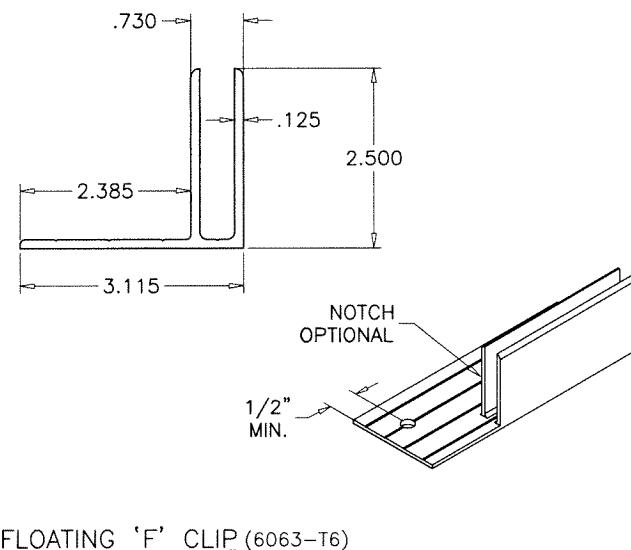

FLOATING 'F' CLIP (6063-T6)
(ALT. TO ANGLES)

CLIP LENGTHS MUST BE CUT TO FIT SNUG INTO 1BY TUBE MULLIONS.

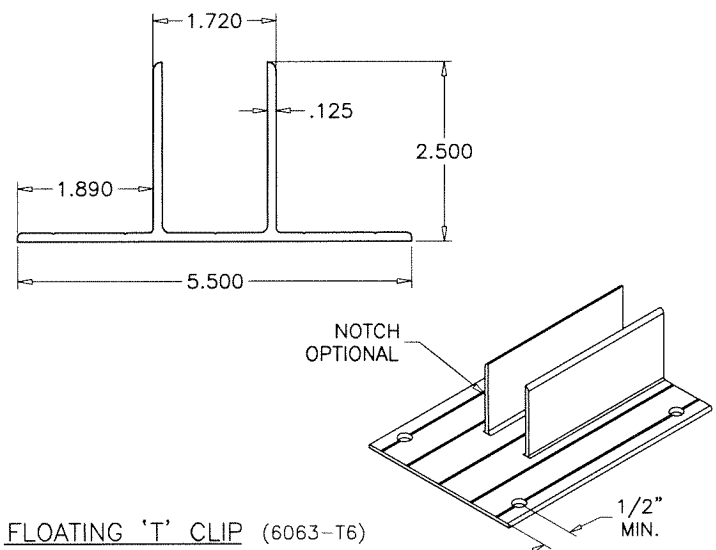

FLOATING 'T' CLIP (6063-T6)
(ALT. TO ANGLES)

CLIP LENGTHS MUST BE CUT TO FIT SNUG INTO 2BY TUBE MULLIONS.

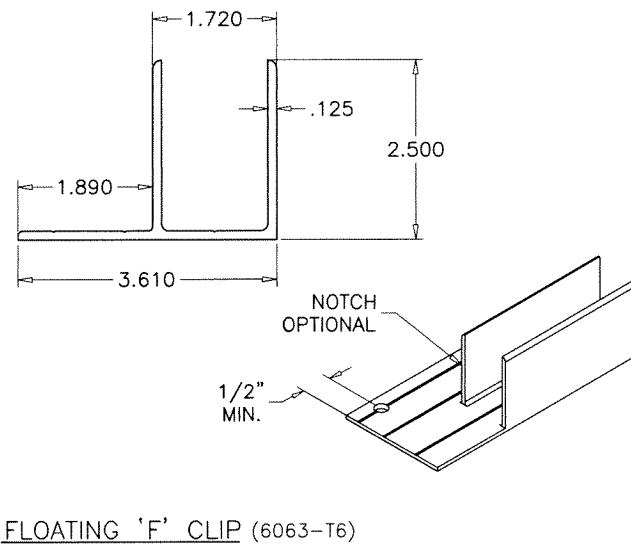

FLOATING 'F' CLIP (6063-T6)
(ALT. TO ANGLES)

CLIP LENGTHS MUST BE CUT TO FIT SNUG INTO 2BY TUBE MULLIONS.

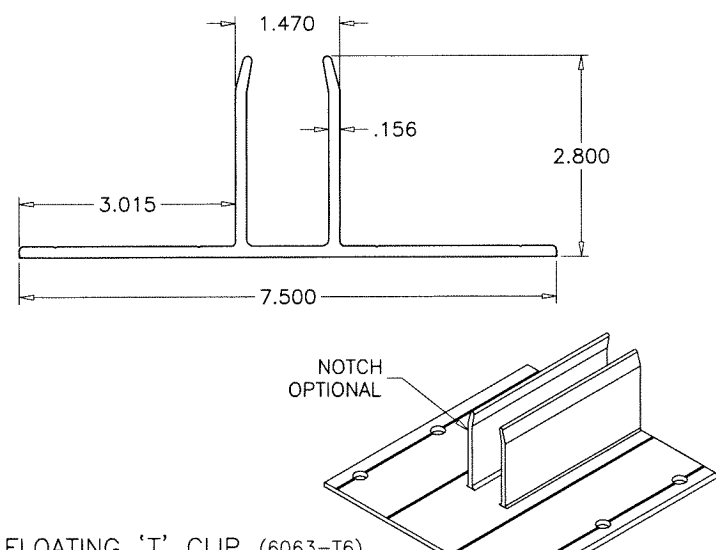

FLOATING 'T' CLIP (6063-T6)
(ALT. TO ANGLES)

CLIP LENGTHS MUST BE CUT TO FIT SNUG INTO 2BY TUBE MULLIONS.

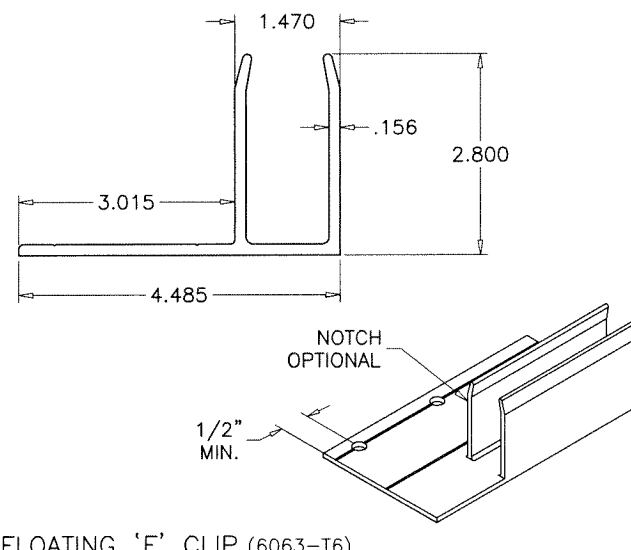

FLOATING 'F' CLIP (6063-T6)
(ALT. TO ANGLES)

CLIP LENGTHS MUST BE CUT TO FIT SNUG INTO 2BY TUBE MULLIONS.

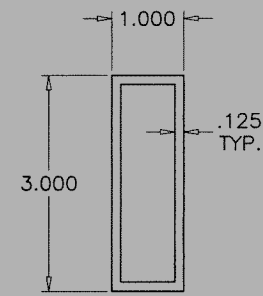

$I_x = .950 \text{ IN}^4$
 $S_x = .633 \text{ IN}^3$
1 X 3
TUBE MULLION
6063-T6

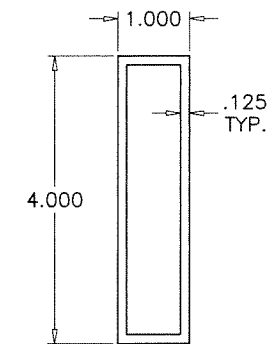

$I_x = 2.040 \text{ IN}^4$
 $S_x = 1.020 \text{ IN}^3$
1 X 4
TUBE MULLION
6063-T6

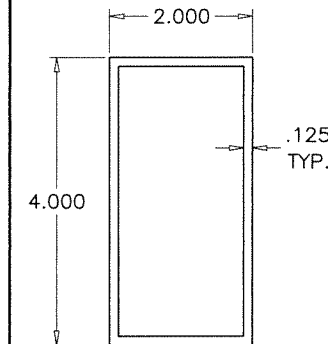

$I_x = 2.980 \text{ IN}^4$
 $S_x = 1.490 \text{ IN}^3$
2 X 4
TUBE MULLION
6063-T6

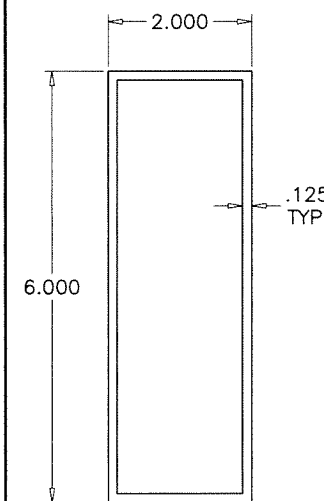

$I_x = 8.280 \text{ IN}^4$
 $S_x = 2.760 \text{ IN}^3$
2 X 6
STD. MULLION
6063-T6

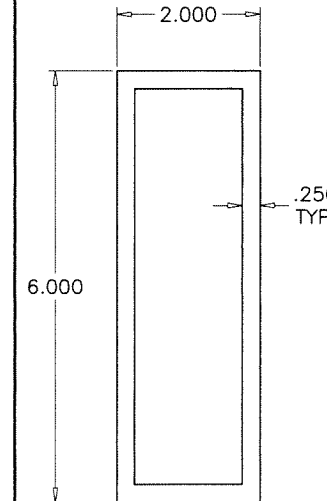

$I_x = 15.200 \text{ IN}^4$
 $S_x = 5.070 \text{ IN}^3$
2 X 6
HEAVY MULLION
6063-T6

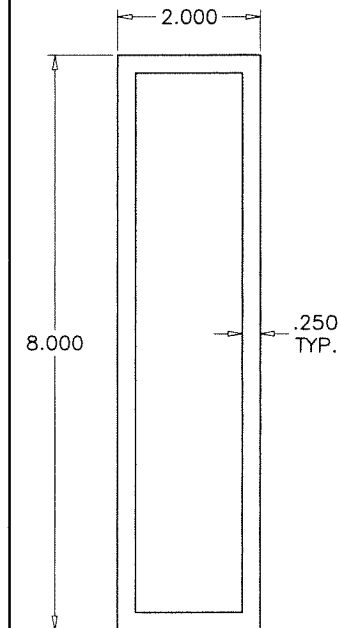

$I_x = 32.599 \text{ IN}^4$
 $S_x = 8.150 \text{ IN}^3$
2 X 8
TUBE MULLION
6063-T6

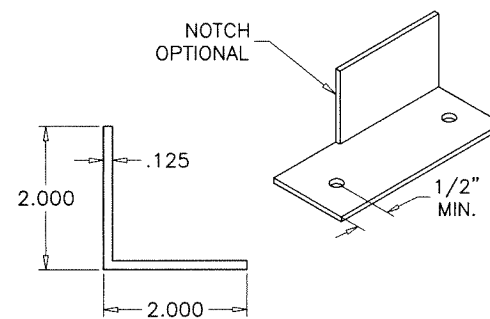

ANGLE CLIP
6063-T6

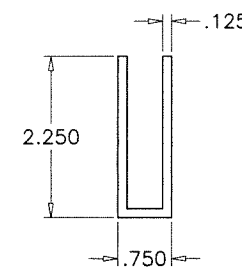

'U' CLIP
6063-T6

Sealed: 7/21/2023

FL #40673

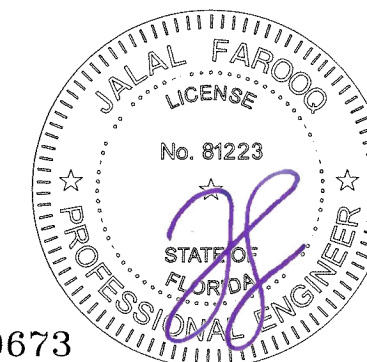

afc
AL-FAROOQ CORPORATION
ENGINEERS & PRODUCT DEVELOPMENT
9360 SUNSET DRIVE, SUITE 220
MIAMI, FLORIDA 33173
WWW.AFCENG.COM
TEL. (305) 264-8100
FBPE #3538
MULLION 21-75F-MG

EXTRUDED ALUMINUM CLIPPED MULLIONS
MR-GLASS DOORS & WINDOWS MANUFACTURING, LLC
8051 N.W. 79th Place
Medley, FL. 33166
Tel. (305) 764-3963
www.mrglasswindows.com

revisions:	no	date	by	description
date:	12-21-21	scale:	3/8" = 1"	
dr. by:	TARIQ	chk. by:		
drawing no.	21-75F			
sheet	2 of 17			

DESIGN LOAD CAPACITY - PSF (TUBE MULLIONS)							
WINDOW DIMS.		1 X 3	1 X 4	2 X 4	2 X 6	2 X 6	2 X 8
WIDTH (W)	MULL SPAN	TUBE	TUBE	TUBE	STD.	HEAVY	TUBE
19-1/8"	38-3/8"	150.0	150.0	150.0	150.0	150.0	150.0
26-1/2"		150.0	150.0	150.0	150.0	150.0	150.0
30"		150.0	150.0	150.0	150.0	150.0	150.0
37"		150.0	150.0	150.0	150.0	150.0	150.0
42"		150.0	150.0	150.0	150.0	150.0	150.0
48"		140.6	150.0	150.0	150.0	150.0	150.0
54"		124.9	150.0	150.0	150.0	150.0	150.0
60"		112.5	150.0	150.0	150.0	150.0	150.0
66"		102.2	150.0	150.0	150.0	150.0	150.0
72"	93.7	149.6	150.0	150.0	150.0	150.0	
19-1/8"	50-5/8"	150.0	150.0	150.0	150.0	150.0	150.0
26-1/2"		143.9	150.0	150.0	150.0	150.0	150.0
30"		127.1	150.0	150.0	150.0	150.0	150.0
37"		103.0	150.0	150.0	150.0	150.0	150.0
42"		90.8	144.7	150.0	150.0	150.0	150.0
48"		79.4	126.6	150.0	150.0	150.0	150.0
54"		70.6	112.5	150.0	150.0	150.0	150.0
60"		63.5	101.3	150.0	150.0	150.0	150.0
66"		57.8	92.1	142.6	150.0	150.0	150.0
72"	53.0	84.4	130.7	150.0	150.0	150.0	
19-1/8"	63"	123.3	150.0	150.0	150.0	150.0	150.0
26-1/2"		89.0	145.6	150.0	150.0	150.0	150.0
30"		78.6	128.6	150.0	150.0	150.0	150.0
37"		63.7	104.3	150.0	150.0	150.0	150.0
42"		56.1	91.9	143.3	150.0	150.0	150.0
48"		49.1	80.4	125.4	150.0	150.0	150.0
54"		43.7	71.5	111.5	150.0	150.0	150.0
60"		39.3	64.3	100.3	150.0	150.0	150.0
66"		35.7	58.5	91.2	150.0	150.0	150.0
72"	32.7	53.6	83.6	150.0	150.0	150.0	
19-1/8"	74-1/4"	75.3	143.2	150.0	150.0	150.0	150.0
26-1/2"		54.4	103.4	150.0	150.0	150.0	150.0
30"		48.0	91.3	143.4	150.0	150.0	150.0
37"		38.9	74.0	116.3	150.0	150.0	150.0
42"		34.3	65.2	102.4	150.0	150.0	150.0
48"		30.0	57.1	89.6	150.0	150.0	150.0
54"		26.7	50.7	79.7	146.3	150.0	150.0
60"		24.0	45.7	71.7	131.7	150.0	150.0
66"		21.8	41.5	65.2	119.7	150.0	150.0
72"	20.0	38.0	59.7	109.7	150.0	150.0	
19-1/8"	76"	70.2	136.4	150.0	150.0	150.0	150.0
26-1/2"		50.7	98.5	150.0	150.0	150.0	150.0
30"		44.8	87.0	136.7	150.0	150.0	150.0
37"		36.3	70.5	110.8	150.0	150.0	150.0
42"		32.0	62.1	97.6	150.0	150.0	150.0
48"		28.0	54.4	85.4	150.0	150.0	150.0
54"		24.9	48.3	75.9	139.5	150.0	150.0
60"		22.4	43.5	68.4	125.5	150.0	150.0
66"		20.3	39.5	62.1	114.1	150.0	150.0
72"	-	36.2	57.0	104.6	150.0	150.0	

DESIGN LOAD CAPACITY - PSF (TUBE MULLIONS)							
WINDOW DIMS.		1 X 3	1 X 4	2 X 4	2 X 6	2 X 6	2 X 8
WIDTH (W)	MULL SPAN	TUBE	TUBE	TUBE	STD.	HEAVY	TUBE
19-1/8"	84"	52.0	110.6	150.0	150.0	150.0	150.0
26-1/2"		37.5	79.8	117.7	150.0	150.0	150.0
30"		33.2	70.5	104.0	150.0	150.0	150.0
37"		26.9	57.2	84.3	150.0	150.0	150.0
42"		23.7	50.4	74.3	146.0	150.0	150.0
48"		20.7	44.1	65.0	127.7	150.0	150.0
54"		-	39.2	57.8	113.5	150.0	150.0
60"		-	35.3	52.0	102.2	150.0	150.0
66"		-	32.1	47.3	92.9	150.0	150.0
72"	-	29.4	43.3	85.2	150.0	150.0	
19-1/8"	96"	34.8	74.8	109.3	150.0	150.0	150.0
26-1/2"		25.1	54.0	78.9	150.0	150.0	150.0
30"		22.2	47.7	69.7	150.0	150.0	150.0
37"		-	38.7	56.5	125.9	150.0	150.0
42"		-	34.1	49.8	110.9	150.0	150.0
48"		-	29.8	43.5	97.0	150.0	150.0
54"		-	26.5	38.7	86.2	150.0	150.0
60"		-	23.8	34.8	77.6	142.0	150.0
66"		-	21.7	31.7	70.6	129.1	150.0
72"	-	-	29.0	64.7	118.3	150.0	
19-1/8"	108"	24.5	52.5	76.8	150.0	150.0	150.0
26-1/2"		-	37.9	55.4	137.8	150.0	150.0
30"		-	33.5	48.9	121.8	150.0	150.0
37"		-	27.2	39.7	98.7	150.0	150.0
42"		-	23.9	35.0	87.0	150.0	150.0
48"		-	20.9	30.6	76.1	139.2	150.0
54"		-	-	27.2	67.6	123.7	150.0
60"		-	-	24.5	60.9	111.3	150.0
66"		-	-	22.2	55.3	101.2	150.0
72"	-	-	20.4	50.7	92.8	147.7	
19-1/8"	120"	-	38.3	56.0	150.0	150.0	150.0
26-1/2"		-	27.6	40.4	110.9	150.0	150.0
30"		-	24.4	35.7	97.9	150.0	150.0
37"		-	-	28.9	79.4	145.2	150.0
42"		-	-	25.5	69.9	127.9	150.0
48"		-	-	22.3	61.2	111.9	150.0
54"		-	-	-	54.4	99.5	150.0
60"		-	-	-	49.0	89.5	142.4
66"		-	-	-	44.5	81.4	129.4
72"	-	-	-	40.8	74.6	118.7	
19-1/8"	132"	-	28.8	42.0	116.8	150.0	150.0
26-1/2"		-	20.8	30.3	84.3	150.0	150.0
30"		-	-	26.8	74.5	136.7	150.0
37"		-	-	21.7	60.4	110.8	150.0
42"		-	-	-	53.2	97.6	150.0
48"		-	-	-	46.5	85.4	146.0
54"		-	-	-	41.4	75.9	129.8
60"		-	-	-	37.2	68.4	116.8
66"		-	-	-	33.8	62.1	106.2
72"	-	-	-	31.0	57.0	97.3	

DESIGN LOAD CAPACITY - PSF (TUBE MULLIONS)							
WINDOW DIMS.		1 X 3	1 X 4	2 X 4	2 X 6	2 X 6	2 X 8
WIDTH (W)	MULL SPAN	TUBE	TUBE	TUBE	STD.	HEAVY	TUBE
19-1/8"	144"	-	22.2	32.4	90.0	150.0	150.0
26-1/2"		-	-	23.4	64.9	119.2	150.0
30"		-	-	20.6	57.4	105.3	150.0
37"		-	-	-	46.5	85.4	150.0
42"		-	-	-	41.0	75.2	139.2
48"		-	-	-	35.8	65.8	121.8
54"		-	-	-	31.9	58.5	108.2
60"		-	-	-	28.7	52.6	97.4
66"		-	-	-	26.1	47.9	88.6
72"	-	-	-	23.9	43.9	81.2	
19-1/8"	156"	-	-	-	70.8	129.9	150.0
26-1/2"		-	-	-	51.1	93.8	150.0
30"		-	-	-	45.1	82.8	150.0
37"		-	-	-	36.6	67.1	133.6
42"		-	-	-	32.2	59.2	117.7
48"		-	-	-	28.2	51.8	103.0
54"		-	-	-	25.1	46.0	91.6
60"		-	-	-	22.6	41.4	82.4
66"		-	-	-	20.5	37.6	74.9
72"	-	-	-	-	34.5	68.7	
19-1/8"	168"	-	-	-	57.7	105.9	150.0
26-1/2"		-	-	-	41.6	76.4	150.0
30"		-	-	-	36.8	67.5	141.1
37"		-	-	-	29.8	54.7	114.4
42"		-	-	-	26.3	48.2	100.8
48"		-	-	-	23.0	42.2	88.2
54"		-	-	-	20.4	37.5	78.4
60"		-	-	-	-	33.7	70.6
66"		-	-	-	-	30.7	64.2
72"	-	-	-	-	28.1	58.8	

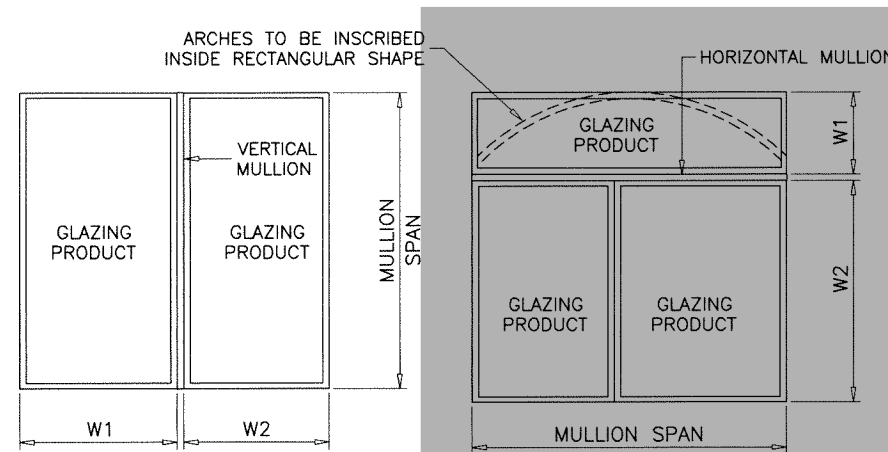

TYPICAL MULLION ARRANGEMENTS

$$WIDTH (W) = \frac{W1 + W2}{2}$$

NOTE:
MULLIONS RATED IN THESE CHARTS MAY BE ORIENTED VERTICALLY OR HORIZONTALLY.
(INTERPOLATION BETWEEN WIDTHS ALLOWED)

Sealed: 7/21/2023



ALL LOADS ARE EXT.(+)/INT.(-).

FL #40673

afc
AL-FAROOQ CORPORATION
ENGINEERS & PRODUCT DEVELOPMENT
9360 SUNSET DRIVE, SUITE 220
MIAMI, FLORIDA 33173
WWW.AFCENG.COM
TEL. (305) 264-8100
FBPE #3538
MULLION 21-75F-MG

EXTRUDED ALUMINUM CLIPPED MULLIONS

MR-GLASS DOORS & WINDOWS MANUFACTURING, LLC
8051 N.W. 79th Place
Medley, FL 33166
Tel. (305) 764-3963
www.mrglasswindows.com

revisions:
no. date by description

date: 12-21-21
scale: -
dr. by: TARIQ
chk. by:

drawing no. 21-75F
sheet 3 of 17

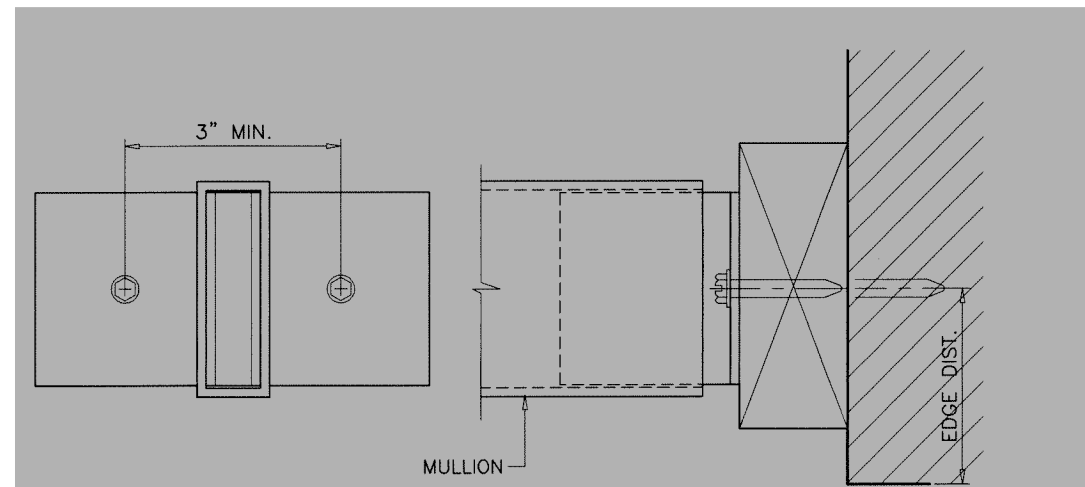
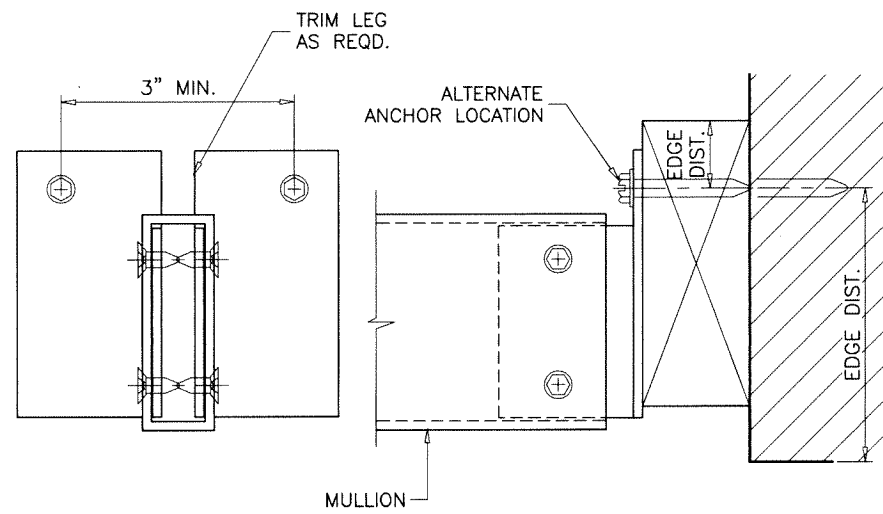
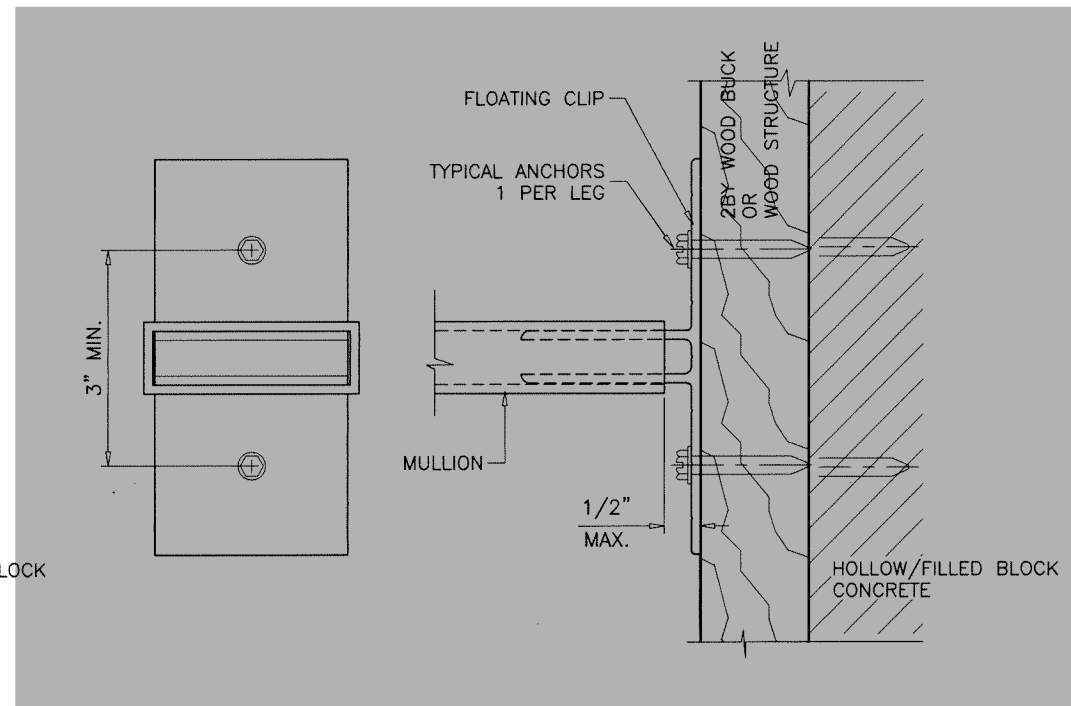
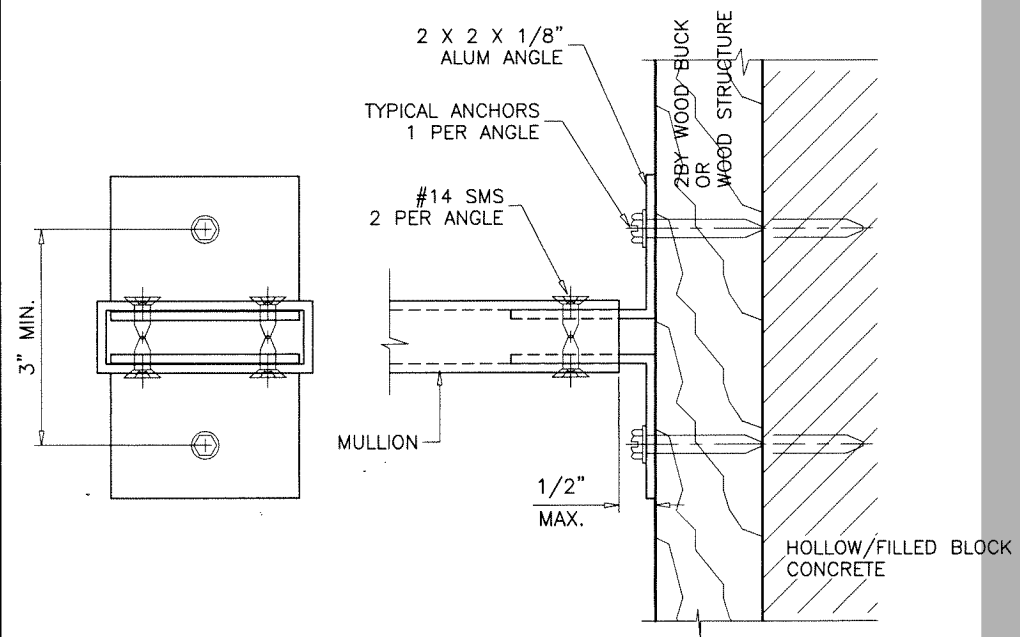

TYPICAL ANCHORS TYPE 'W2'
 INTO 2BY WOOD BUCKS OR WOOD STRUCTURES
 THRU 1BY BUCKS INTO CONC. OR MASONRY
 SEE SHEET 6 FOR 'T' CLIP ANCHOR CAPACITIES

afc
AL-FAROOQ CORPORATION
 ENGINEERS & PRODUCT DEVELOPMENT
 9360 SUNSET DRIVE, SUITE 220
 MIAMI, FLORIDA 33173
 WWW.AFCENG.COM
 TEL. (305) 264-8100
 FBPE #3538
 MULLION\21-75F-MG

EXTRUDED ALUMINUM CLIPPED MULLIONS
MR-GLASS DOORS & WINDOWS MANUFACTURING, LLC
 8051 N.W. 79th Place
 Medley, FL. 33166
 Tel. (305) 764-3963
 www.mrglasswindows.com

revisions:	
no	date by description

date: 12-21-21
 scale: 3/8" = 1"
 dr. by: TARIQ
 chk. by:

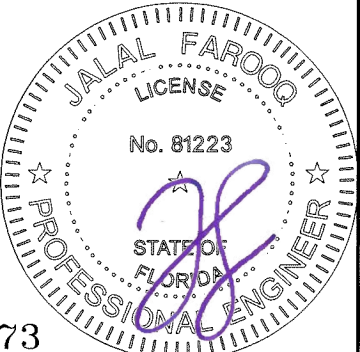

Sealed: 7/21/2023

FL #40673

drawing no.
21-75F
 sheet 4 of 17

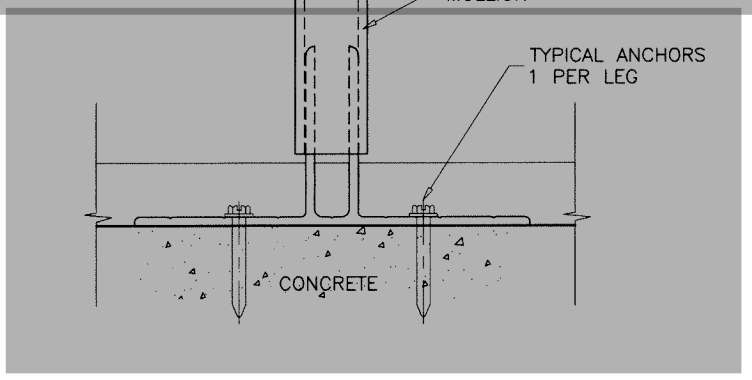
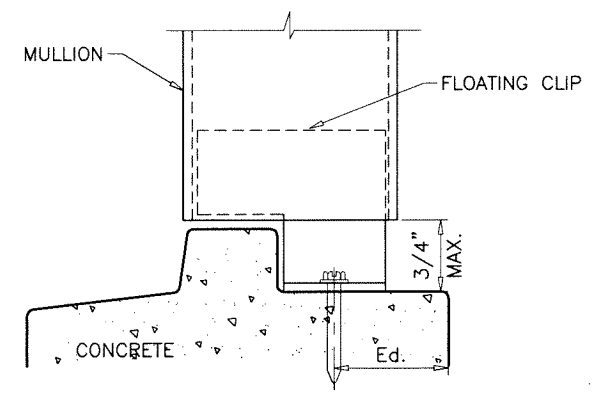
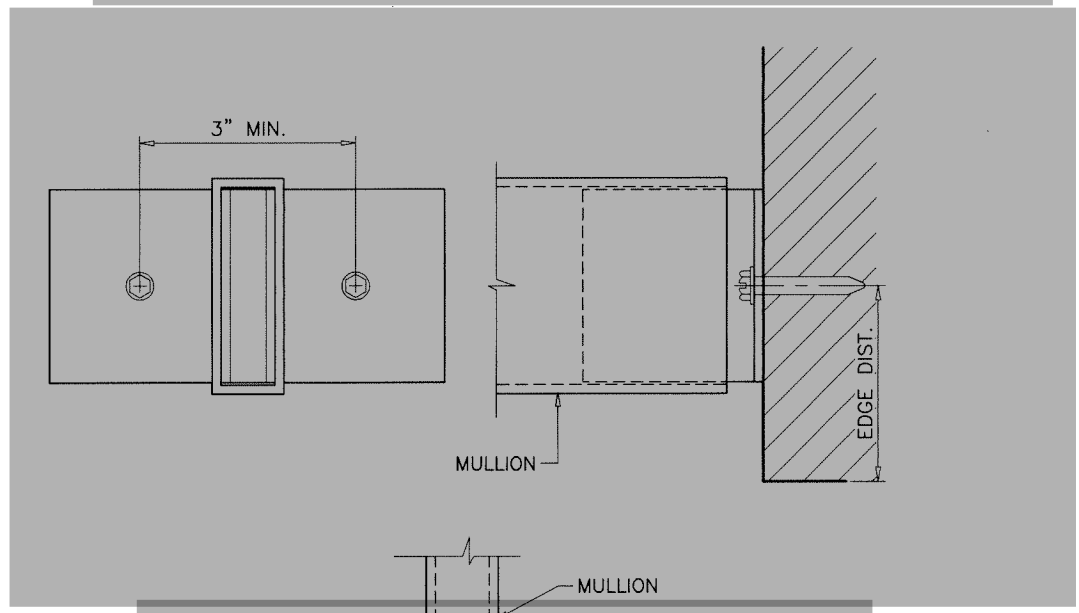
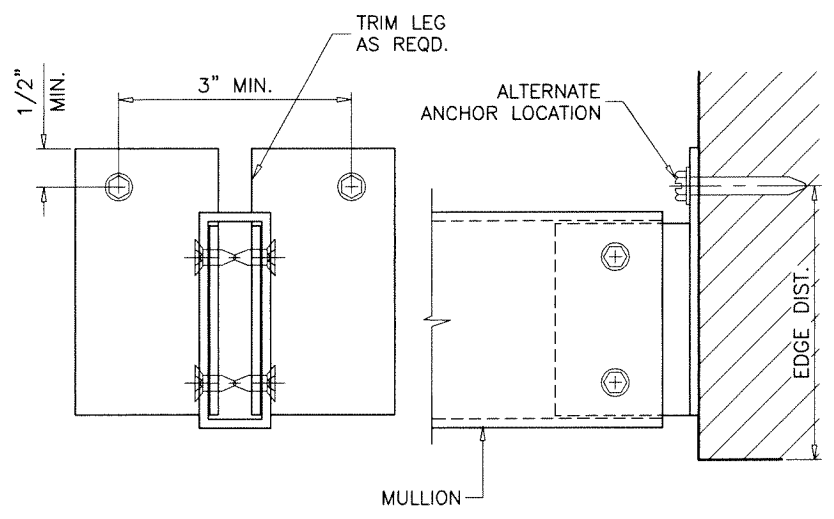
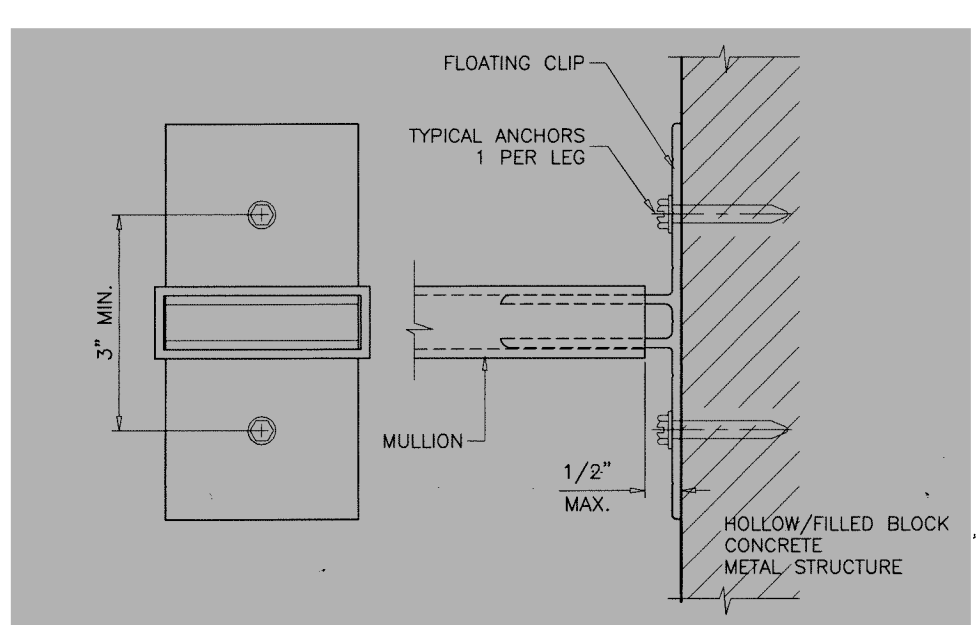
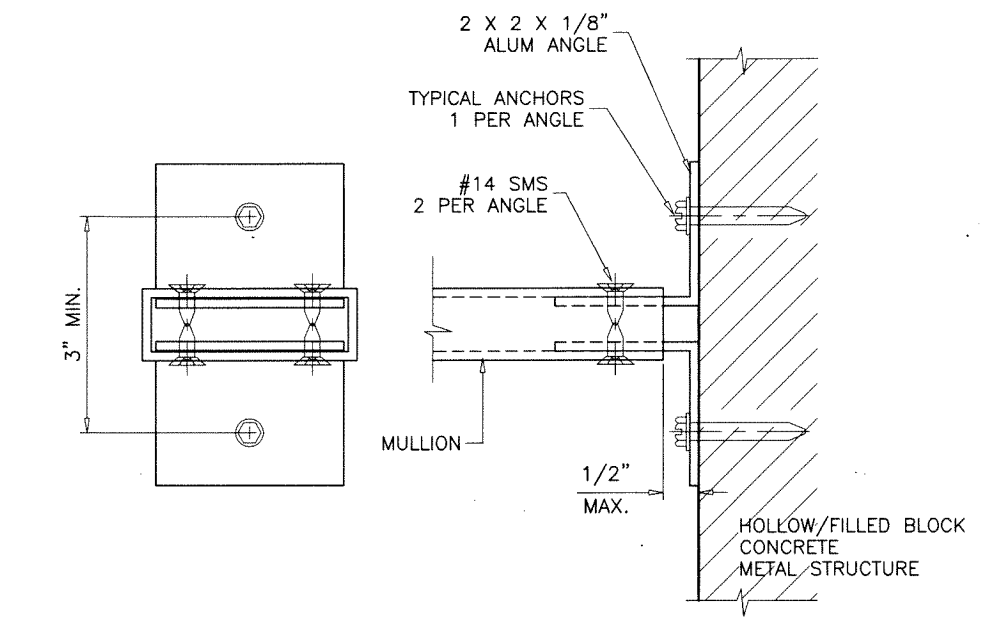

TYPICAL ANCHORS TYPE 'B2', 'C2', 'M2'

DIRECTLY INTO HOLLOW/FILLED BLOCK
 DIRECTLY INTO CONCRETE
 INTO METAL STRUCTURES

SEE SHEET 6 FOR 'T' CLIP ANCHOR CAPACITIES

Sealed: 7/21/2023

FL #40673

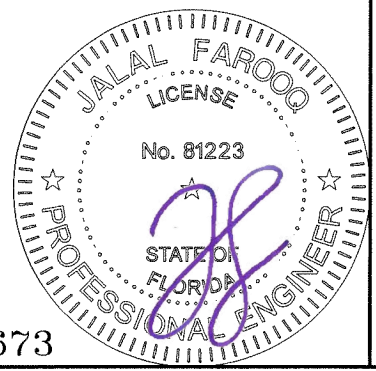

afC
AL-FAROOQ CORPORATION
 ENGINEERS & PRODUCT DEVELOPMENT
 9360 SUNSET DRIVE, SUITE 220
 MIAMI, FLORIDA 33173
 TEL: (305) 264-8100 WWW.AFCENG.COM
 FBPE #8588
 MULLION\21-75F-MG

EXTRUDED ALUMINUM CLIPPED MULLIONS
MR-GLASS DOORS & WINDOWS MANUFACTURING, LLC
 8051 N.W. 79th Place
 Medley, FL. 33166
 Tel. (305) 764-3963 www.mrglasswindows.com

revisions:	
no	date by description

date: 12-21-21	scale: 3/8" = 1"	dr. by: TARIQ	chk. by:
drawing no. 21-75F			
sheet 5 of 17			

DESIGN LOAD CAPACITY - PSF					
WINDOW DIMS.		ANCHORS TYPE			
WIDTH (W)	MULL SPAN	W2T	B2T	C2T	M2T
19-1/8"	38-3/8"	150.0	150.0	150.0	150.0
26-1/2"		149.5	150.0	150.0	150.0
30"		132.1	145.1	150.0	150.0
37"		107.1	117.6	150.0	150.0
42"		94.3	103.6	150.0	139.7
48"		82.6	90.7	133.5	122.3
54"		73.4	80.6	118.7	108.7
60"		66.0	72.5	106.8	97.8
66"		60.0	66.0	97.1	88.9
72"		55.0	60.5	89.0	81.5
19-1/8"	50-5/8"	150.0	150.0	150.0	150.0
26-1/2"		113.3	124.5	150.0	150.0
30"		100.1	110.0	150.0	148.3
37"		81.2	89.2	131.3	120.2
42"		71.5	78.6	115.7	105.9
48"		62.6	68.7	101.2	92.7
54"		55.6	61.1	90.0	82.4
60"		50.1	55.0	81.0	74.1
66"		45.5	50.0	73.6	67.4
72"		41.7	45.8	67.5	61.8
19-1/8"	63"	126.2	138.6	150.0	150.0
26-1/2"		91.1	100.1	147.3	134.9
30"		80.5	88.4	130.1	119.2
37"		65.2	71.7	105.5	96.6
42"		57.5	63.1	93.0	85.1
48"		50.3	55.2	81.3	74.5
54"		44.7	49.1	72.3	66.2
60"		40.2	44.2	65.1	59.6
66"		36.6	40.2	59.2	54.2
72"		33.5	36.8	54.2	49.7
19-1/8"	74-1/4"	107.1	117.6	150.0	150.0
26-1/2"		77.3	84.9	125.0	114.5
30"		68.3	75.0	110.4	101.1
37"		55.4	60.8	89.5	82.0
42"		48.8	53.6	78.9	72.2
48"		42.7	46.9	69.0	63.2
54"		37.9	41.7	61.3	56.2
60"		34.1	37.5	55.2	50.6
66"		31.0	34.1	50.2	46.0
72"		28.4	31.2	46.0	42.1
19-1/8"	76"	104.6	114.9	150.0	150.0
26-1/2"		75.5	82.9	122.1	111.8
30"		66.7	73.3	107.9	98.8
37"		54.1	59.4	87.5	80.1
42"		47.6	52.3	77.1	70.6
48"		41.7	45.8	67.4	61.7
54"		37.1	40.7	59.9	54.9
60"		33.3	36.6	53.9	49.4
66"		30.3	33.3	49.0	44.9
72"		27.8	30.5	44.9	41.2

DESIGN LOAD CAPACITY - PSF					
WINDOW DIMS.		ANCHORS TYPE			
WIDTH (W)	MULL SPAN	W2T	B2T	C2T	M2T
19-1/8"	84"	94.7	104.0	150.0	140.2
26-1/2"		68.3	75.0	110.5	101.2
30"		60.3	66.3	97.6	89.4
37"		48.9	53.7	79.1	72.5
42"		43.1	47.3	69.7	63.8
48"		37.7	41.4	61.0	55.9
54"		33.5	36.8	54.2	49.7
60"		30.2	33.1	48.8	44.7
66"		27.4	30.1	44.4	40.6
72"		25.1	27.6	40.7	37.2
19-1/8"	96"	82.8	91.0	134.0	122.7
26-1/2"		59.8	65.7	96.7	88.5
30"		52.8	58.0	85.4	78.2
37"		42.8	47.0	69.2	63.4
42"		37.7	41.4	61.0	55.9
48"		33.0	36.3	53.4	48.9
54"		29.3	32.2	47.4	43.4
60"		26.4	29.0	42.7	39.1
66"		24.0	26.4	38.8	35.5
72"		22.0	24.2	35.6	32.6
19-1/8"	108"	73.6	80.9	119.1	109.0
26-1/2"		53.1	58.4	85.9	78.7
30"		46.9	51.6	75.9	69.5
37"		38.1	41.8	61.5	56.4
42"		33.5	36.8	54.2	49.7
48"		29.3	32.2	47.4	43.4
54"		26.1	28.6	42.2	38.6
60"		23.5	25.8	38.0	34.8
66"		21.3	23.4	34.5	31.6
72"		-	21.5	31.6	29.0
19-1/8"	120"	66.3	72.8	107.2	98.1
26-1/2"		47.8	52.5	77.3	70.8
30"		42.2	46.4	68.3	62.6
37"		34.2	37.6	55.4	50.7
42"		30.2	33.1	48.8	44.7
48"		26.4	29.0	42.7	39.1
54"		23.5	25.8	38.0	34.8
60"		21.1	23.2	34.2	31.3
66"		-	21.1	31.1	28.4
72"		-	-	28.5	26.1
19-1/8"	132"	60.2	66.2	97.4	89.2
26-1/2"		43.5	47.8	70.3	64.4
30"		38.4	42.2	62.1	56.9
37"		31.1	34.2	50.4	46.1
42"		27.4	30.1	44.4	40.6
48"		24.0	26.4	38.8	35.5
54"		21.3	23.4	34.5	31.6
60"		-	21.1	31.1	28.4
66"		-	-	28.2	25.9
72"		-	-	25.9	23.7

DESIGN LOAD CAPACITY - PSF					
WINDOW DIMS.		ANCHORS TYPE			
WIDTH (W)	MULL SPAN	W2T	B2T	C2T	M2T
19-1/8"	144"	55.2	60.7	89.3	81.8
26-1/2"		39.8	43.8	64.5	59.0
30"		35.2	38.7	56.9	52.1
37"		28.5	31.4	46.2	42.3
42"		25.1	27.6	40.7	37.2
48"		22.0	24.2	35.6	32.6
54"		-	21.5	31.6	29.0
60"		-	-	28.5	26.1
66"		-	-	25.9	23.7
72"		-	-	23.7	21.7
19-1/8"	156"	51.0	56.0	82.4	75.5
26-1/2"		36.8	40.4	59.5	54.5
30"		32.5	35.7	52.6	48.1
37"		26.3	28.9	42.6	39.0
42"		23.2	25.5	37.5	34.4
48"		20.3	22.3	32.8	30.1
54"		-	-	29.2	26.7
60"		-	-	26.3	24.1
66"		-	-	23.9	21.9
72"		-	-	21.9	20.1
19-1/8"	168"	47.3	52.0	76.5	70.1
26-1/2"		34.2	37.5	55.2	50.6
30"		30.2	33.1	48.8	44.7
37"		24.5	26.9	39.6	36.2
42"		21.6	23.7	34.9	31.9
48"		-	20.7	30.5	27.9
54"		-	-	27.1	24.8
60"		-	-	24.2	22.3
66"		-	-	22.2	20.3
72"		-	-	20.3	-

TYPICAL ANCHORS AT 'T' CLIP:

1/4" DIA. ULTRACON+ BY 'DEWALT' (Fu=164 KSI, Fy=148 KSI)

W2T: INTO 2BY WOOD BUCKS OR WOOD STRUCTURES
1-1/2" MIN. PENETRATION INTO WOOD

W2T: THRU 1BY BUCKS INTO CONCRETE OR BLOCKS
1-1/4" MIN. EMBED INTO CONCRETE OR BLOCKS

B2T: DIRECTLY INTO HOLLOW/FILLED BLOCKS
1-1/4" MIN. EMBED INTO BLOCKS

C2T: DIRECTLY INTO CONCRETE
1-3/4" MIN. EMBED INTO CONCRETE

#14 SMS OR SELF-DRILLING SCREWS (GRADE 2 CRS)

M2T: INTO METAL STRUCTURES
(3) THREADS MIN. TO EXTEND BEYOND METAL THICKNESS
ALUMINUM: 1/8" THK. MIN. (6063-T5 MIN.)
STEEL: 1/8" THK. MIN. (Fy = 36 KSI MIN.)
(STEEL IN CONTACT WITH ALUMINUM TO BE PLATED OR PAINTED)

TYPICAL EDGE DISTANCE

INTO CONCRETE AND BLOCKS = 2-1/2" MIN.
INTO WOOD STRUCTURE = 1" MIN.
INTO METAL STRUCTURE = 3/4" MIN.

WOOD AT HEAD, SILL OR JAMBS SG = 0.55 MIN.
CONCRETE AT HEAD, SILL OR JAMBS f'c = 3000 PSI MIN.
C-90 HOLLOW/FILLED NORMAL WEIGHT BLOCK AT JAMBS f'm = 2000 PSI MIN.

ANCHORS MAY BE HEX OR FLAT HEAD

NOTE:
ANY ANCHOR CONDITION SHOWN HEREIN MAY COVER LOCATIONS
AT HEAD, SILL OR JAMB ENDS.
SEE SHEETS 4 & 5 FOR ANCHOR DETAILS.

(INTERPOLATION BETWEEN WIDTHS OR SPANS ALLOWED)

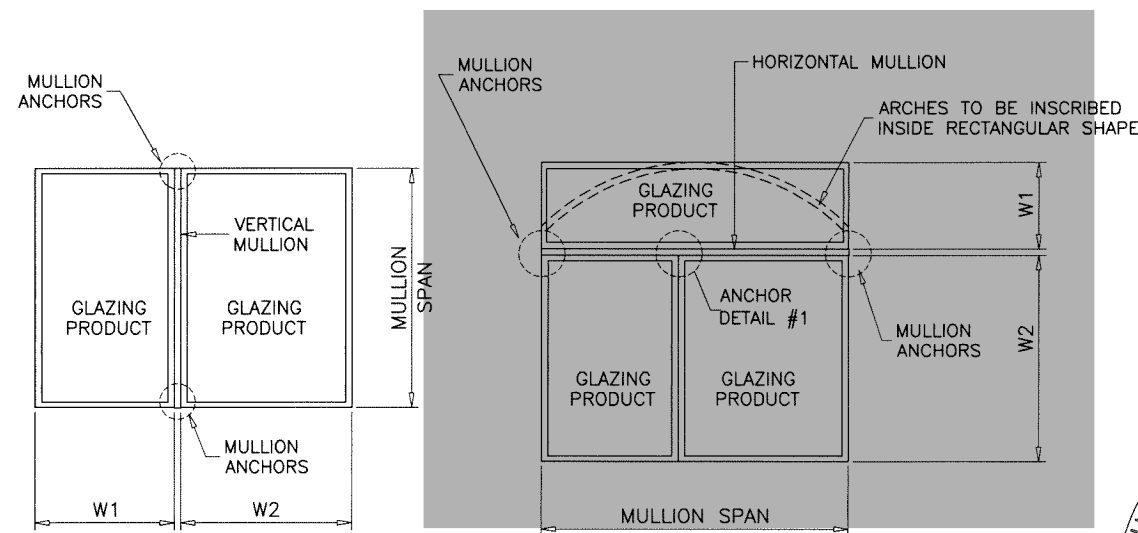

TYPICAL MULLION ARRANGEMENTS

$$\text{WIDTH (W)} = \frac{W1 + W2}{2}$$

Sealed: 7/21/2023

FL #40673

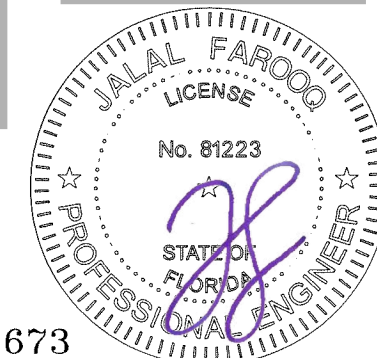

ALL LOADS ARE EXT.(+)/INT.(-).

afC
AL-FAROOQ CORPORATION
ENGINEERS & PRODUCT DEVELOPMENT
9360 SUNSET DRIVE, SUITE 220
MIAMI, FLORIDA 33173
TEL. (305) 264-8100
WWW.AFCENG.COM
MULLION \ 21-75F-MG
FBPE #3538

EXTRUDED ALUMINUM CLIPPED MULLIONS
MR-GLASS DOORS & WINDOWS MANUFACTURING, LLC
8051 N.W. 79th Place
Medley, FL. 33166
Tel. (305) 764-3963
www.mrglasswindows.com

revisions:
no. date by description
date: 12-21-21
scale: -
dr. by: TARIQ
chk. by:
drawing no.
21-75F
sheet 6 of 17

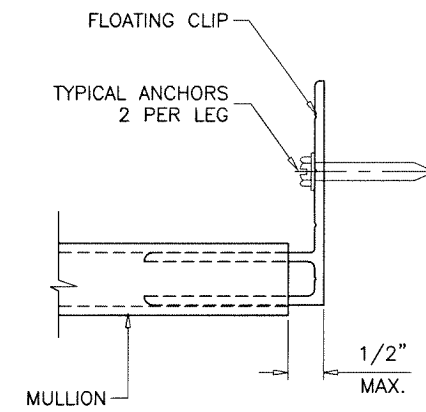
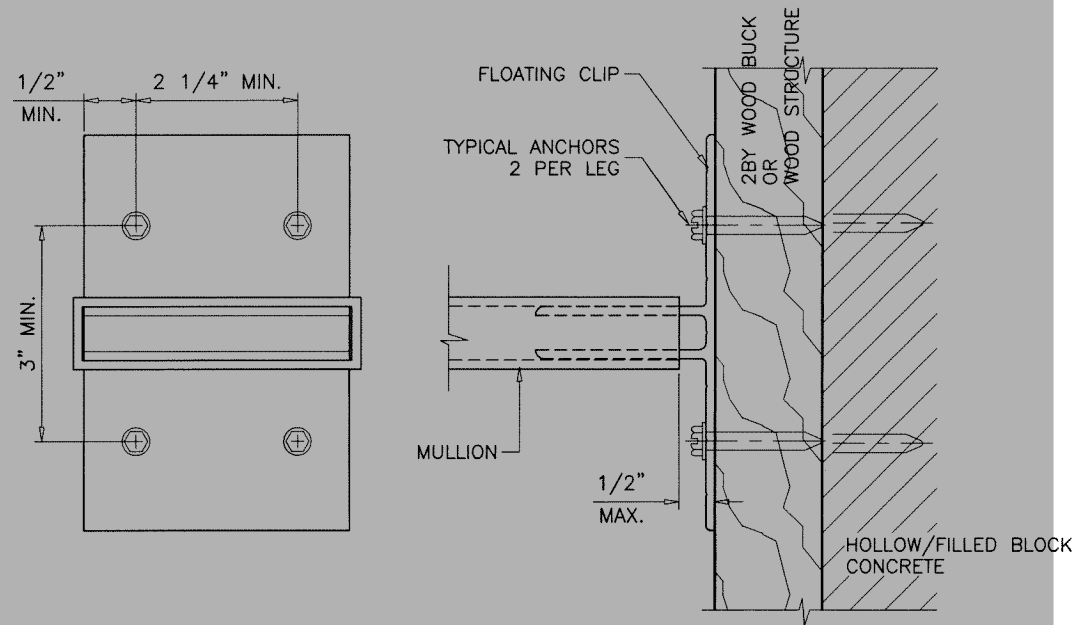
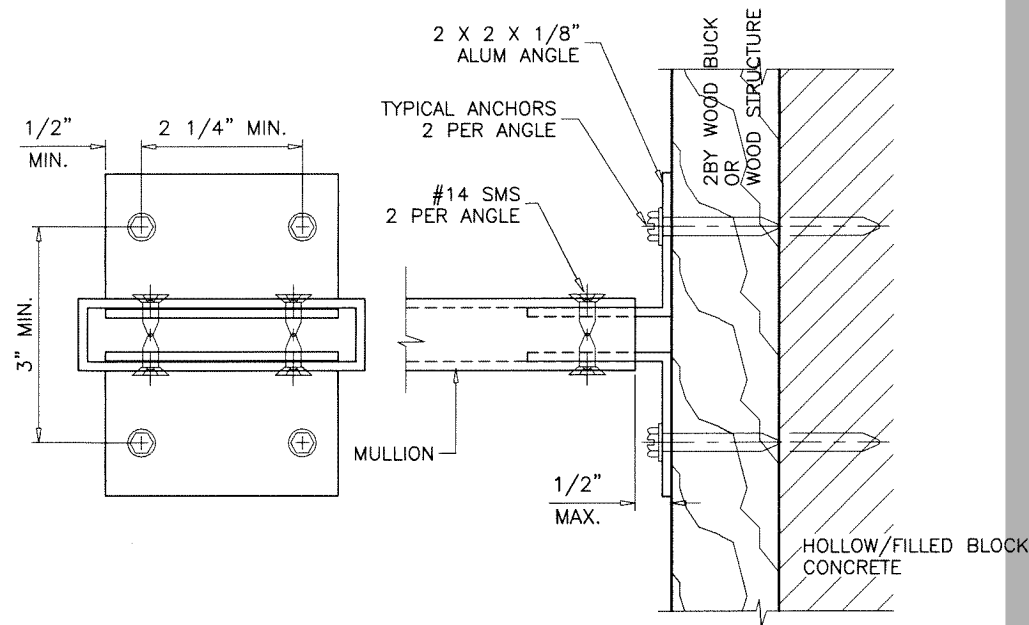

'F' CLIP DETAIL
 APPLICABLE TO ALL SUBSTRATES
 SHOWN FOR 'T' CLIP

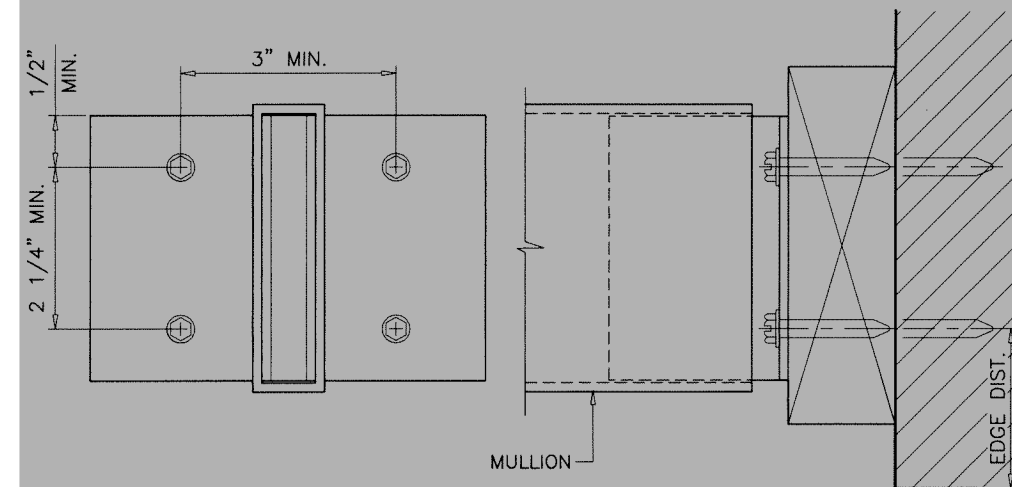
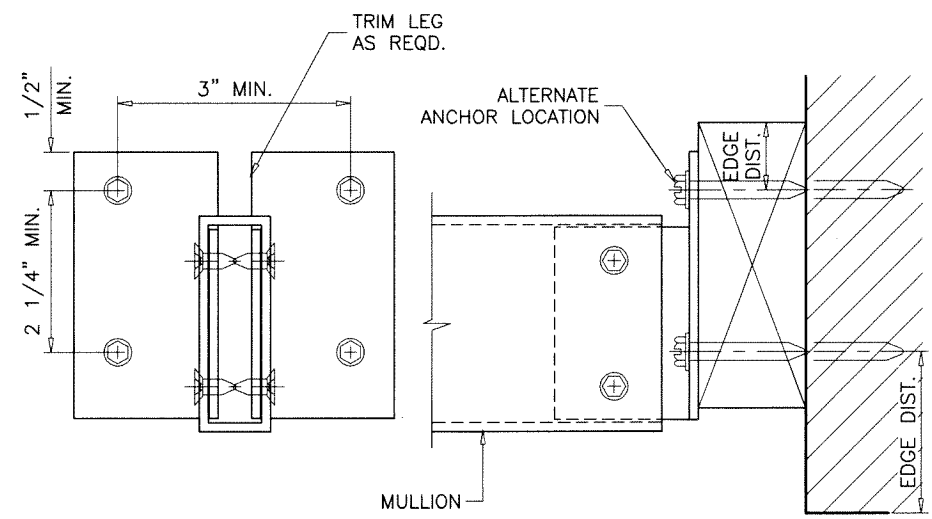

TYPICAL ANCHORS TYPE 'W4'
 INTO 2BY WOOD BUCKS OR WOOD STRUCTURES
 THRU 1BY BUCKS INTO CONC. OR MASONRY

SEE SHEET 9 FOR 'T' CLIP ANCHOR CAPACITIES
 SEE SHEET 9.1 FOR 'F' CLIP ANCHOR CAPACITIES

afc
AL-FAROOQ CORPORATION
 ENGINEERS & PRODUCT DEVELOPMENT
 9360 SUNSET DRIVE, SUITE 220
 MIAMI, FLORIDA 33173
 TEL. (305) 264-8100 WWW.AFCENG.COM
 FBPE #3538 MULLION\21-75F-MG

EXTRUDED ALUMINUM CLIPPED MULLIONS
MR-GLASS DOORS & WINDOWS MANUFACTURING, LLC
 8051 N.W. 79th Place
 Medley, FL. 33166
 Tel. (305) 764-3963 www.mrglasswindows.com

revisions:	no	date	by	description

date: 12-21-21
 scale: 3/8" = 1"
 dr. by: TARIQ
 chk. by:

drawing no.
21-75F
 sheet 7 of 17

Sealed: 7/21/2023

FL #40673



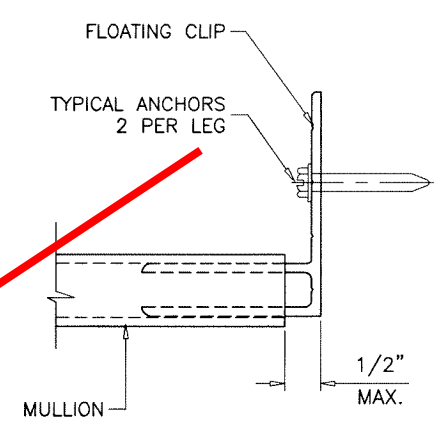
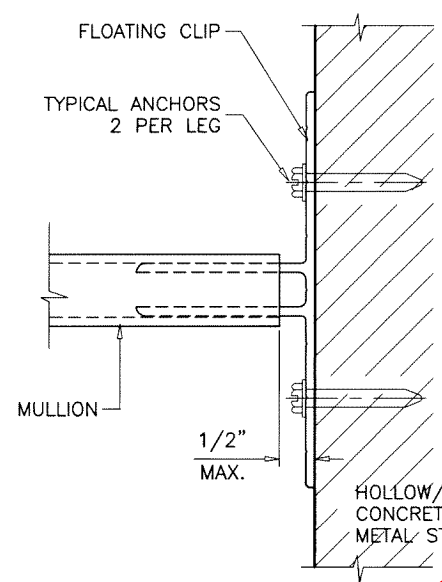
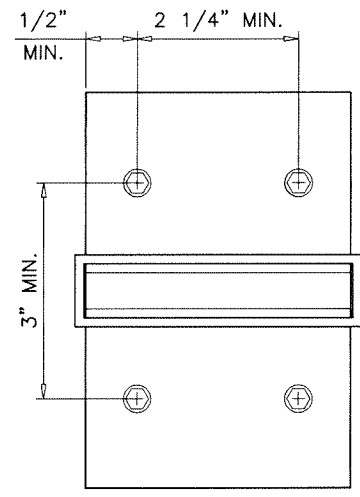
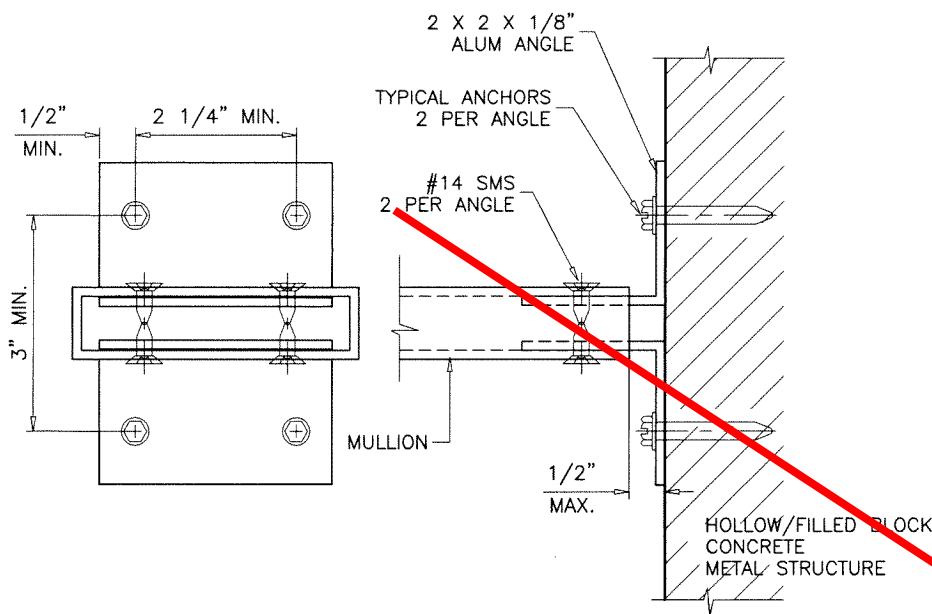

'F' CLIP DETAIL
 APPLICABLE TO ALL SUBSTRATES
 SHOWN FOR 'T' CLIP

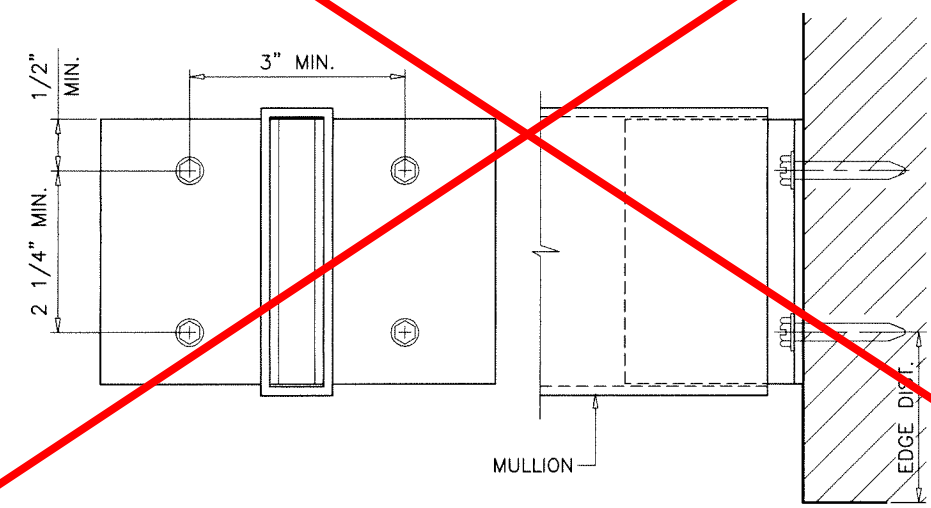
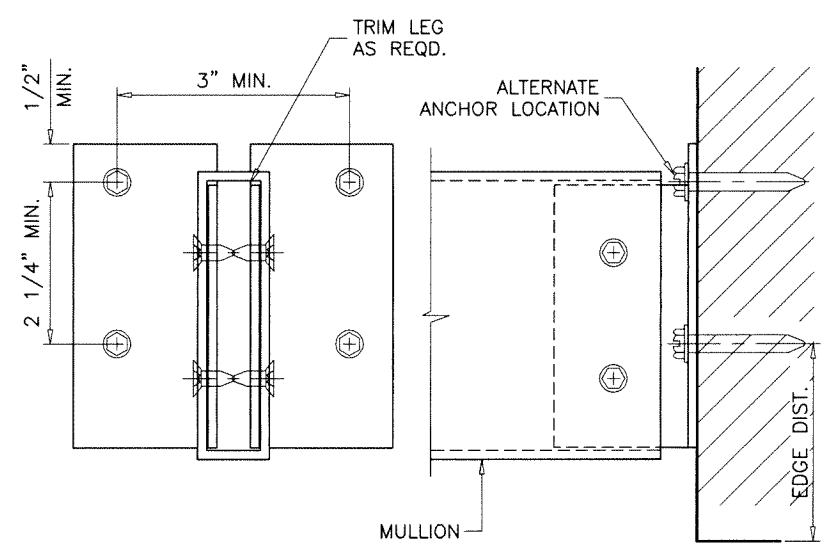

TYPICAL ANCHORS TYPE 'B4', 'C4', 'M4'
 DIRECTLY INTO HOLLOW/FILLED BLOCK
 DIRECTLY INTO CONCRETE
 INTO METAL STRUCTURES

SEE SHEET 9 FOR 'T' CLIP ANCHOR CAPACITIES
 SEE SHEET 9.1 FOR 'F' CLIP ANCHOR CAPACITIES

af c
AL-FAROOQ CORPORATION
 ENGINEERS & PRODUCT DEVELOPMENT
 9360 SUNSET DRIVE, SUITE 220
 MIAMI, FLORIDA 33173
 TEL. (305) 264-8100 WWW.AFCENG.COM
 FBPE #3538 MULLION\21-75F-MG

EXTRUDED ALUMINUM CLIPPED MULLIONS
MR-GLASS DOORS & WINDOWS MANUFACTURING, LLC
 8051 N.W. 79th Place
 Medley, FL. 33166
 Tel. (305) 764-3963 www.mrglasswindows.com

revisions:	
no	date by description

date: 12-21-21	scale: 3/8" = 1"
dr. by: TARIQ	chk. by:

drawing no.	21-75F
sheet	8 of 17



Sealed: 7/21/2023

FL #40673

DESIGN LOAD CAPACITY - PSF					
WINDOW DIMS.		ANCHORS TYPE			
WIDTH (W)	MULL SPAN	W4T	B4T	C4T	M4T
19-1/8"	38-3/8"	150.0	150.0	150.0	150.0
26-1/2"		150.0	150.0	150.0	150.0
30"		150.0	150.0	150.0	150.0
37"		150.0	150.0	150.0	150.0
42"		150.0	150.0	150.0	150.0
48"		150.0	150.0	150.0	150.0
54"		146.8	147.5	150.0	150.0
60"		132.1	132.6	150.0	150.0
66"		120.1	120.5	150.0	150.0
72"	110.1	110.5	150.0	150.0	
19-1/8"	50-5/8"	150.0	150.0	150.0	150.0
26-1/2"		150.0	150.0	150.0	150.0
30"		150.0	150.0	150.0	150.0
37"		150.0	150.0	150.0	150.0
42"		143.0	143.6	150.0	150.0
48"		125.2	125.6	150.0	150.0
54"		111.2	111.7	150.0	150.0
60"		100.1	100.5	150.0	148.3
66"		91.0	91.4	145.8	134.8
72"	83.4	83.8	133.7	123.6	
19-1/8"	63"	150.0	150.0	150.0	150.0
26-1/2"		150.0	150.0	150.0	150.0
30"		150.0	150.0	150.0	150.0
37"		130.5	131.0	150.0	150.0
42"		114.9	115.4	150.0	150.0
48"		100.6	101.0	150.0	149.0
54"		89.4	89.7	143.2	132.4
60"		80.5	80.8	128.9	119.2
66"		73.1	73.4	117.2	108.3
72"	67.0	67.3	107.4	99.3	
19-1/8"	74-1/4"	150.0	150.0	150.0	150.0
26-1/2"		150.0	150.0	150.0	150.0
30"		136.5	137.1	150.0	150.0
37"		110.7	111.1	150.0	150.0
42"		97.5	97.9	150.0	144.4
48"		85.3	85.7	136.7	126.4
54"		75.9	76.1	121.5	112.3
60"		68.3	68.5	109.4	101.1
66"		62.1	62.3	99.4	91.9
72"	56.9	57.1	91.2	84.3	
19-1/8"	76"	150.0	150.0	150.0	150.0
26-1/2"		150.0	150.0	150.0	150.0
30"		133.4	133.9	150.0	150.0
37"		108.2	108.6	150.0	150.0
42"		95.3	95.6	150.0	141.1
48"		83.4	83.7	133.6	123.5
54"		74.1	74.4	118.7	109.8
60"		66.7	66.9	106.9	98.8
66"		60.6	60.9	97.1	89.8
72"	55.6	55.8	89.1	82.3	

DESIGN LOAD CAPACITY - PSF					
WINDOW DIMS.		ANCHORS TYPE			
WIDTH (W)	MULL SPAN	W4T	B4T	C4T	M4T
19-1/8"	84"	150.0	150.0	150.0	150.0
26-1/2"		136.6	137.1	150.0	150.0
30"		120.7	121.1	150.0	150.0
37"		97.9	98.2	150.0	144.9
42"		86.2	86.5	138.1	127.7
48"		75.4	75.7	120.9	111.7
54"		67.0	67.3	107.4	99.3
60"		60.3	60.6	96.7	89.4
66"		54.9	55.1	87.9	81.2
72"	50.3	50.5	80.6	74.5	
19-1/8"	96"	150.0	150.0	150.0	150.0
26-1/2"		119.5	120.0	150.0	150.0
30"		105.6	106.0	150.0	150.0
37"		85.6	85.9	137.2	126.8
42"		75.4	75.7	120.9	111.7
48"		66.0	66.3	105.8	97.8
54"		58.7	58.9	94.0	86.9
60"		52.8	53.0	84.6	78.2
66"		48.0	48.2	76.9	71.1
72"	44.0	44.2	50.5	65.2	
19-1/8"	108"	147.2	147.8	150.0	150.0
26-1/2"		106.3	106.7	150.0	150.0
30"		93.9	94.2	150.0	139.0
37"		76.1	76.4	121.9	112.7
42"		67.0	67.3	107.4	99.3
48"		58.7	58.9	94.0	86.9
54"		52.1	52.3	83.6	77.2
60"		46.9	47.1	75.2	69.5
66"		42.7	42.8	68.4	63.2
72"	39.1	39.3	62.7	57.9	
19-1/8"	120"	132.5	133.0	150.0	150.0
26-1/2"		95.6	96.0	150.0	141.6
30"		84.5	84.8	135.4	125.1
37"		68.5	68.8	109.8	101.4
42"		60.3	60.6	96.7	89.4
48"		52.8	53.0	84.6	78.2
54"		46.9	47.1	75.2	69.5
60"		42.2	42.4	67.7	62.6
66"		38.4	38.5	61.5	56.9
72"	35.2	35.3	56.4	52.1	
19-1/8"	132"	120.5	120.9	150.0	150.0
26-1/2"		86.9	87.3	139.3	128.8
30"		76.8	77.1	123.1	113.7
37"		62.3	62.5	99.8	92.2
42"		54.9	55.1	87.9	81.2
48"		48.0	48.2	76.9	71.1
54"		42.7	42.8	68.4	63.2
60"		38.4	38.5	61.5	56.9
66"		34.9	35.0	55.9	51.7
72"	32.0	32.1	51.3	47.4	

DESIGN LOAD CAPACITY - PSF					
WINDOW DIMS.		ANCHORS TYPE			
WIDTH (W)	MULL SPAN	W4T	B4T	C4T	M4T
19-1/8"	144"	110.4	110.8	150.0	150.0
26-1/2"		79.7	80.0	127.7	118.0
30"		70.4	70.7	112.8	104.3
37"		57.1	57.3	91.5	84.5
42"		50.3	50.5	80.6	74.5
48"		44.0	44.2	70.5	65.2
54"		39.1	39.3	62.7	57.9
60"		35.2	35.3	56.4	52.1
66"		32.0	32.1	51.3	47.4
72"	29.3	29.4	47.0	43.4	
19-1/8"	156"	101.9	102.3	150.0	150.0
26-1/2"		73.6	73.8	117.9	109.0
30"		65.0	65.2	104.1	96.2
37"		52.7	52.9	84.4	78.0
42"		46.4	46.6	74.4	68.7
48"		40.6	40.8	66.5	60.2
54"		36.1	36.2	57.8	53.5
60"		32.5	32.6	52.1	48.1
66"		29.5	29.7	47.3	43.7
72"	27.1	27.2	43.4	40.1	
19-1/8"	168"	94.7	95.0	150.0	140.2
26-1/2"		68.3	68.6	109.5	101.2
30"		60.3	60.6	96.7	89.4
37"		48.9	49.1	78.4	72.5
42"		43.1	43.3	69.1	63.8
48"		37.7	37.9	60.4	55.9
54"		33.5	33.7	53.7	49.7
60"		30.2	30.3	48.3	44.7
66"		27.4	27.5	43.9	40.6
72"	25.1	25.2	40.3	37.2	

TYPICAL ANCHORS AT 'T' CLIP:

1/4" DIA. ULTRACON+ BY 'DEWALT' (Fu=164 KSI, Fy=148 KSI)

- W4T: INTO 2BY WOOD BUCKS OR WOOD STRUCTURES
1-1/2" MIN. PENETRATION INTO WOOD
- W4T: THRU 1BY BUCKS INTO CONCRETE OR BLOCKS
1-1/4" MIN. EMBED INTO CONCRETE OR BLOCKS
- B4T: DIRECTLY INTO HOLLOW/FILLED BLOCKS
1-1/4" MIN. EMBED INTO BLOCK
- C4T: DIRECTLY INTO CONCRETE
1-3/4" MIN. EMBED INTO CONCRETE

#14 SMS OR SELF-DRILLING SCREWS (GRADE 2 CRS)

- M4T: INTO METAL STRUCTURES
(3) THREADS MIN. TO EXTEND BEYOND METAL THICKNESS
ALUMINUM: 1/8" THK. MIN. (6063-T5 MIN.)
STEEL: 1/8" THK. MIN. (Fy = 36 KSI MIN.)
(STEEL IN CONTACT WITH ALUMINUM TO BE PLATED OR PAINTED)

TYPICAL EDGE DISTANCE

- INTO CONCRETE AND BLOCKS = 2-1/2" MIN.
- INTO WOOD STRUCTURE = 1" MIN.
- INTO METAL STRUCTURE = 3/4" MIN.

WOOD AT HEAD, SILL OR JAMBS SG = 0.55 MIN.
CONCRETE AT HEAD, SILL OR JAMBS f'c = 3000 PSI MIN.
C-90 HOLLOW/FILLED NORMAL WEIGHT BLOCK AT JAMBS f'm = 2000 PSI MIN.

ANCHORS MAY BE HEX OR FLAT HEAD

NOTE:
ANY ANCHOR CONDITION SHOWN HEREIN MAY COVER LOCATIONS AT HEAD, SILL OR JAMB ENDS.
SEE SHEETS 7 & 8 FOR ANCHOR DETAILS.

(INTERPOLATION BETWEEN WIDTHS OR SPANS ALLOWED)

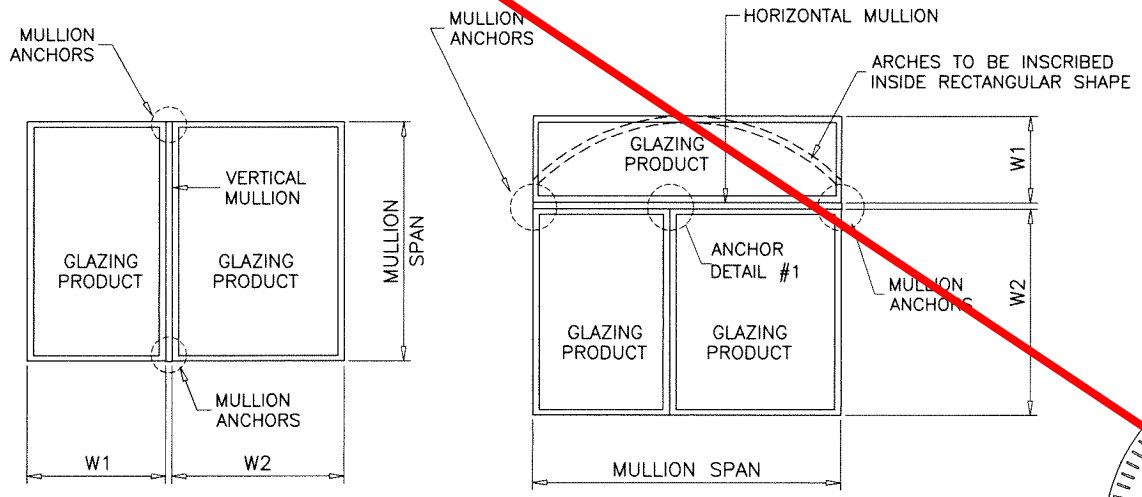

TYPICAL MULLION ARRANGEMENTS

$$\text{WIDTH (W)} = \frac{W1 + W2}{2}$$

ALL LOADS ARE EXT.(+)/INT.(-).

Sealed: 7/21/2023

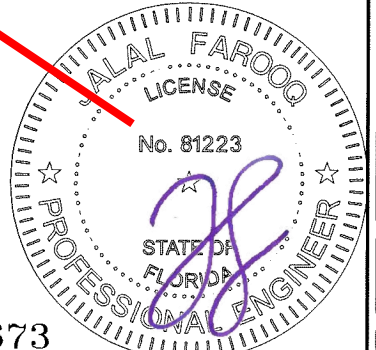

FL #40673

afC
AL-FAROOQ CORPORATION
 ENGINEERS & PRODUCT DEVELOPMENT
 9360 SUNSET DRIVE, SUITE 220
 MIAMI, FLORIDA 33173
 TEL: (305) 264-8100
 WWW.AFCENG.COM
 FBPE #3598

EXTRUDED ALUMINUM CLIPPED MULLIONS
MR-GLASS DOORS & WINDOWS MANUFACTURING, LLC
 8051 N.W. 79th Place
 Medley, FL. 33166
 Tel. (305) 764-3963
 www.mrglasswindows.com

revisions:	no.	date	by	description
date:	12-21-21			
scale:	-			
dr. by:	TARIQ			
chk. by:				
drawing no.	21-75F			
sheet	9 of 17			

DESIGN LOAD CAPACITY - PSF				
WINDOW DIMS.		ANCHORS TYPE		
WIDTH (W)	MULL SPAN	W2F	B2F	M2F
19-1/8"	38-3/8"	150.0	150.0	150.0
26-1/2"		149.5	150.0	150.0
30"		132.1	132.6	150.0
37"		107.1	107.5	150.0
42"		94.3	94.7	150.0
48"		82.6	82.9	132.3
54"		73.4	73.7	107.6
60"		66.0	66.3	105.8
66"		60.0	60.3	96.2
72"		55.0	55.2	88.2
19-1/8"	50-5/8"	150.0	150.0	150.0
26-1/2"		113.3	113.8	150.0
30"		100.1	100.5	150.0
37"		81.2	81.5	130.1
42"		71.5	71.8	114.6
48"		62.6	62.8	100.3
54"		55.6	55.8	89.1
60"		50.1	50.3	80.2
66"		45.5	45.7	72.9
72"		41.7	41.9	66.8
19-1/8"	63"	126.2	126.7	150.0
26-1/2"		91.1	91.4	145.9
30"		80.5	80.8	128.9
37"		65.2	65.5	104.5
42"		57.5	57.7	92.1
48"		50.3	50.5	80.6
54"		44.7	44.9	71.6
60"		40.2	40.4	64.5
66"		36.6	36.7	58.6
72"		33.5	33.7	53.7
19-1/8"	74-1/4"	107.1	107.5	150.0
26-1/2"		77.3	77.6	123.8
30"		68.3	68.5	109.4
37"		55.4	55.6	88.7
42"		48.8	48.9	78.1
48"		42.7	42.8	68.4
54"		37.9	38.1	60.8
60"		34.1	34.3	54.7
66"		31.0	31.1	49.7
72"		28.4	28.6	45.6
19-1/8"	76"	104.6	105.0	150.0
26-1/2"		75.5	75.8	121.0
30"		66.7	66.9	106.9
37"		54.1	54.3	86.6
42"		47.6	47.8	76.3
48"		41.7	41.8	66.8
54"		37.1	37.2	59.4
60"		33.3	33.5	53.4
66"		30.3	30.4	48.6
72"		27.8	27.9	44.5

DESIGN LOAD CAPACITY - PSF				
WINDOW DIMS.		ANCHORS TYPE		
WIDTH (W)	MULL SPAN	W2F	B2F	M2F
19-1/8"	84"	94.7	95.0	150.0
26-1/2"		68.3	68.6	109.5
30"		60.3	60.6	96.7
37"		48.9	49.1	78.4
42"		43.1	43.3	69.1
48"		37.7	37.9	60.4
54"		33.5	33.7	53.7
60"		30.2	30.3	48.3
66"		27.4	27.5	43.9
72"		25.1	25.2	40.3
19-1/8"	96"	82.8	83.1	132.7
26-1/2"		59.8	60.0	95.8
30"		52.8	53.0	84.6
37"		42.8	43.0	68.6
42"		37.7	37.9	60.4
48"		33.0	33.1	52.9
54"		29.3	29.4	47.0
60"		26.4	26.5	42.3
66"		24.0	24.1	38.5
72"		22.0	22.1	35.3
19-1/8"	108"	73.6	73.9	118.0
26-1/2"		53.1	53.3	85.1
30"		46.9	47.1	75.2
37"		38.1	38.2	61.0
42"		33.5	33.7	53.7
48"		29.3	29.4	47.0
54"		26.1	26.2	41.8
60"		23.5	23.6	37.6
66"		21.3	21.4	34.2
72"		-	-	31.3
19-1/8"	120"	66.3	66.5	106.2
26-1/2"		47.8	48.0	76.6
30"		42.2	42.4	67.7
37"		34.2	34.4	54.9
42"		30.2	30.3	48.3
48"		26.4	26.5	42.3
54"		23.5	23.6	37.6
60"		21.1	21.2	33.8
66"		-	-	30.8
72"		-	-	28.2
19-1/8"	132"	60.2	60.5	96.5
26-1/2"		43.5	43.6	69.7
30"		38.4	38.5	61.5
37"		31.1	31.3	49.9
42"		27.4	27.5	43.9
48"		24.0	24.1	38.5
54"		21.3	21.4	34.2
60"		-	-	30.8
66"		-	-	28.0
72"		-	-	25.6

DESIGN LOAD CAPACITY - PSF				
WINDOW DIMS.		ANCHORS TYPE		
WIDTH (W)	MULL SPAN	W2F	B2F	M2F
19-1/8"	144"	55.2	55.4	88.5
26-1/2"		39.8	40.0	63.8
30"		35.2	35.3	56.4
37"		28.5	28.6	45.7
42"		25.1	25.2	40.3
48"		22.0	22.1	35.3
54"		-	-	31.3
60"		-	-	28.2
66"		-	-	25.6
72"		-	-	23.5
19-1/8"	156"	51.0	51.2	81.7
26-1/2"		36.8	36.9	58.9
30"		32.5	32.6	52.1
37"		26.3	26.4	42.2
42"		23.2	23.3	37.2
48"		20.3	20.4	32.5
54"		-	-	28.9
60"		-	-	25.0
66"		-	-	23.7
72"		-	-	21.7
19-1/8"	168"	47.3	47.5	75.8
26-1/2"		34.2	34.3	54.7
30"		30.2	30.3	48.3
37"		24.5	24.6	39.2
42"		21.6	21.6	34.5
48"		-	-	30.2
54"		-	-	26.9
60"		-	-	24.2
66"		-	-	22.0
72"		-	-	20.1

TYPICAL ANCHORS AT 'F' CLIP:

1/4" DIA. ULTRACON+ BY 'DEWALT' (Fu=164 KSI, Fy=148 KSI)

W2F: INTO 2BY WOOD BUCKS OR WOOD STRUCTURES
1-1/2" MIN. PENETRATION INTO WOOD

W2F: THRU 1BY BUCKS INTO CONCRETE OR BLOCKS
1-1/4" MIN. EMBED INTO CONCRETE OR BLOCKS

B2F: DIRECTLY INTO HOLLOW/FILLED BLOCKS
1-1/4" MIN. EMBED INTO BLOCK

C2F: DIRECTLY INTO CONCRETE
1-3/4" MIN. EMBED INTO CONCRETE

#14 SMS OR SELF-DRILLING SCREWS (GRADE 2 CRS)

M2F: INTO METAL STRUCTURES
(3) THREADS MIN. TO EXTEND BEYOND METAL THICKNESS
ALUMINUM: 1/8" THK. MIN. (6063-T5 MIN.)
STEEL: 1/8" THK. MIN. (Fy = 36 KSI MIN.)
(STEEL IN CONTACT WITH ALUMINUM TO BE PLATED OR PAINTED)

TYPICAL EDGE DISTANCE

INTO CONCRETE AND BLOCKS = 2-1/2" MIN.
INTO WOOD STRUCTURE = 1" MIN.
INTO METAL STRUCTURE = 3/4" MIN.

WOOD AT HEAD, SILL OR JAMBS SG = 0.55 MIN.
CONCRETE AT HEAD, SILL OR JAMBS f'c = 3000 PSI MIN.
C-90 HOLLOW/FILLED NORMAL WEIGHT BLOCK AT JAMBS f'm = 2000 PSI MIN.

ANCHORS MAY BE HEX OR FLAT HEAD

NOTE:
ANY ANCHOR CONDITION SHOWN HEREIN MAY COVER LOCATIONS
AT HEAD, SILL OR JAMB ENDS.
SEE SHEETS 7 & 8 FOR ANCHOR DETAILS.

(INTERPOLATION BETWEEN WIDTHS OR SPANS ALLOWED)

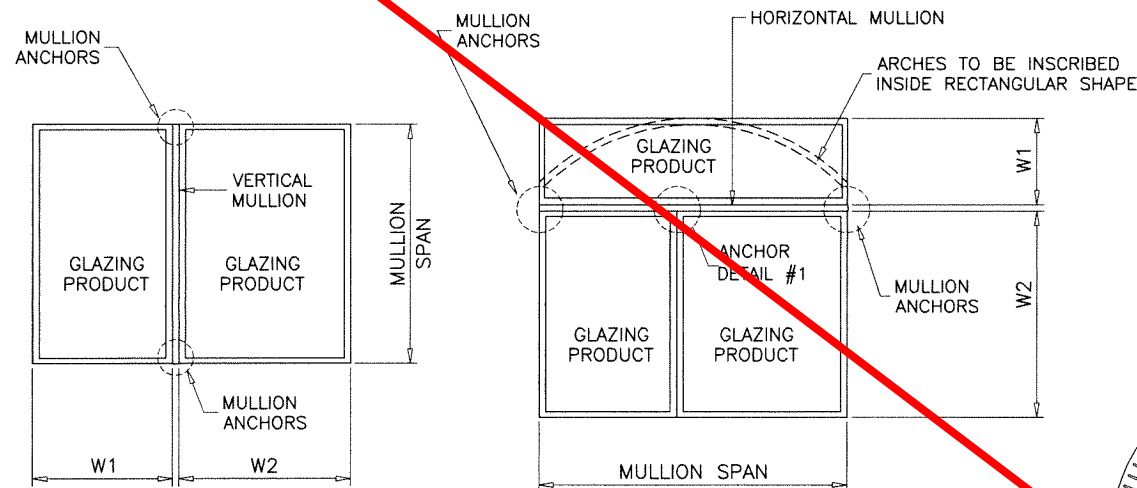

TYPICAL MULLION ARRANGEMENTS

$$\text{WIDTH (W)} = \frac{W1 + W2}{2}$$

Sealed: 7/21/2023

FL #40673

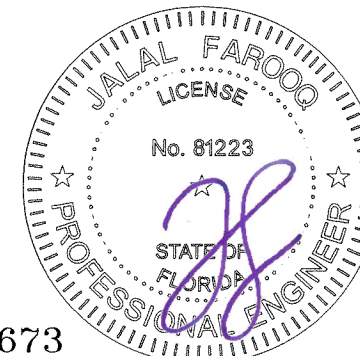

afC
AL-FAROOQ CORPORATION
ENGINEERS & PRODUCT DEVELOPMENT
9360 SUNSET DRIVE, SUITE 220
MIAMI, FLORIDA 33173
TEL. (305) 264-8100
WWW.AFCENG.COM
FBPE #3598

EXTRUDED ALUMINUM CLIPPED MULLIONS
MR-GLASS DOORS & WINDOWS MANUFACTURING, LLC
8051 N.W. 79th Place
Medley, FL. 33166
Tel. (305) 764-3963
www.mrglasswindows.com

revisions:	no.	date	by	description
date:	12-21-21			
scale:	-			
dr. by:	TARIQ			
chk. by:				
drawing no.	21-75F			
sheet	9.1 of 17			

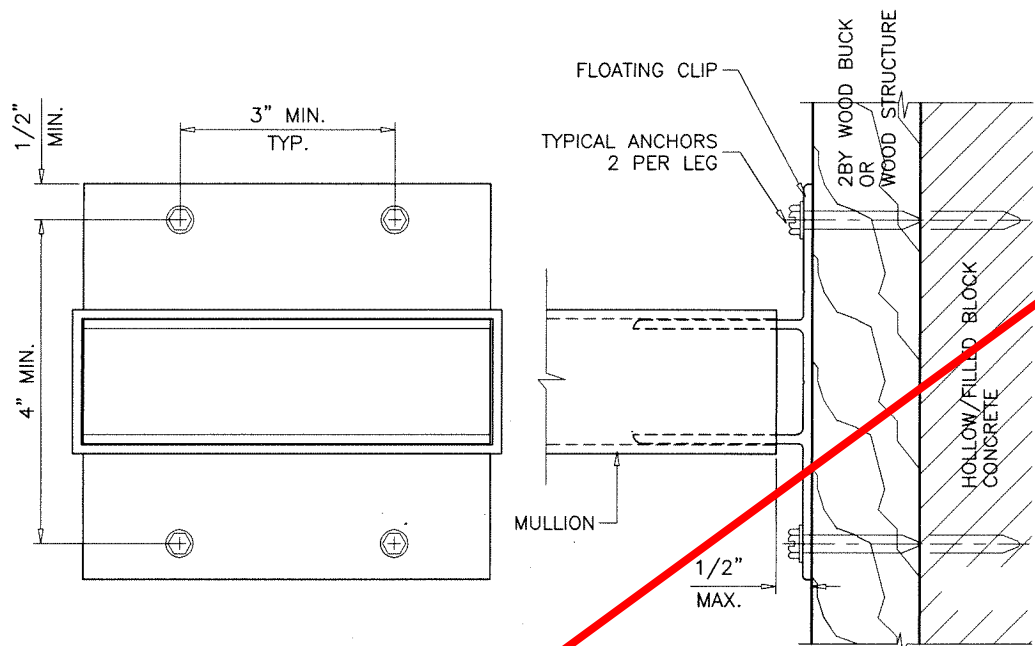
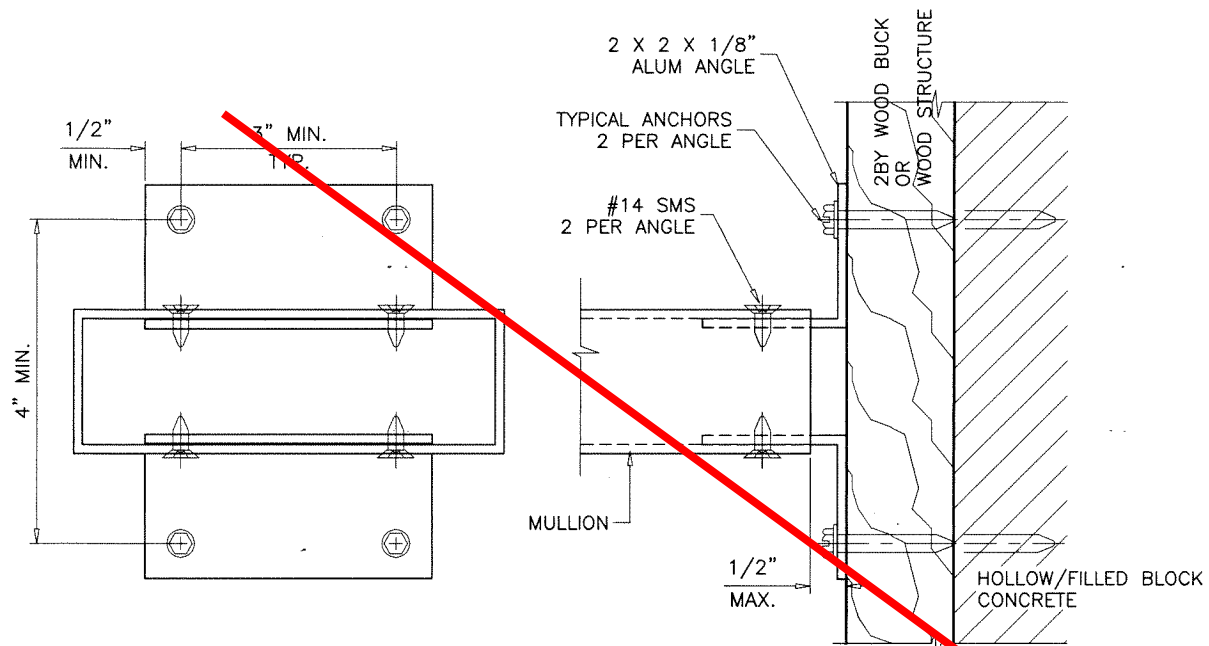

'F' CLIP DETAIL
 APPLICABLE TO ALL SUBSTRATES
 SHOWN FOR 'T' CLIP

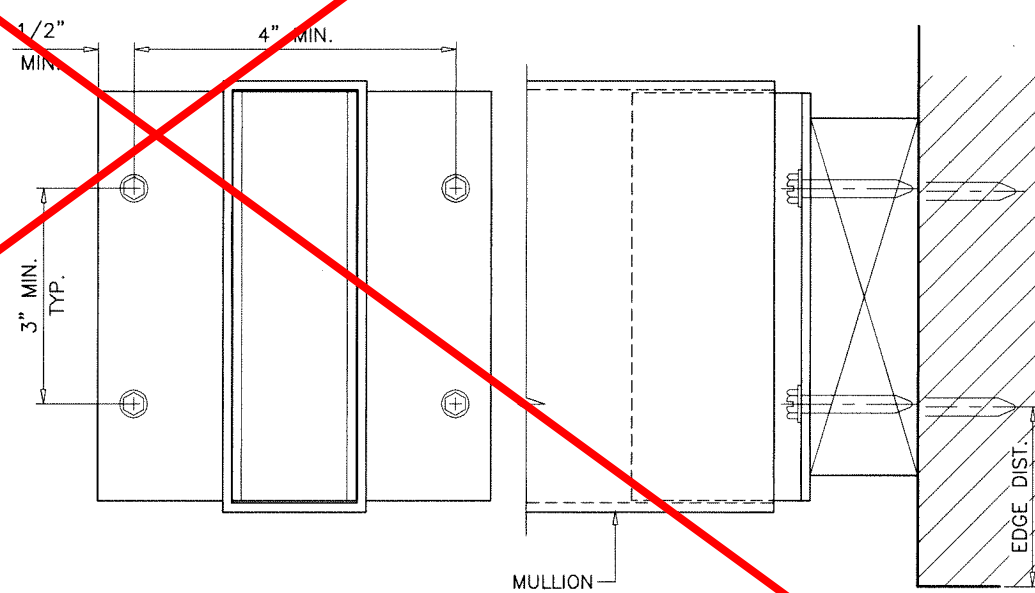
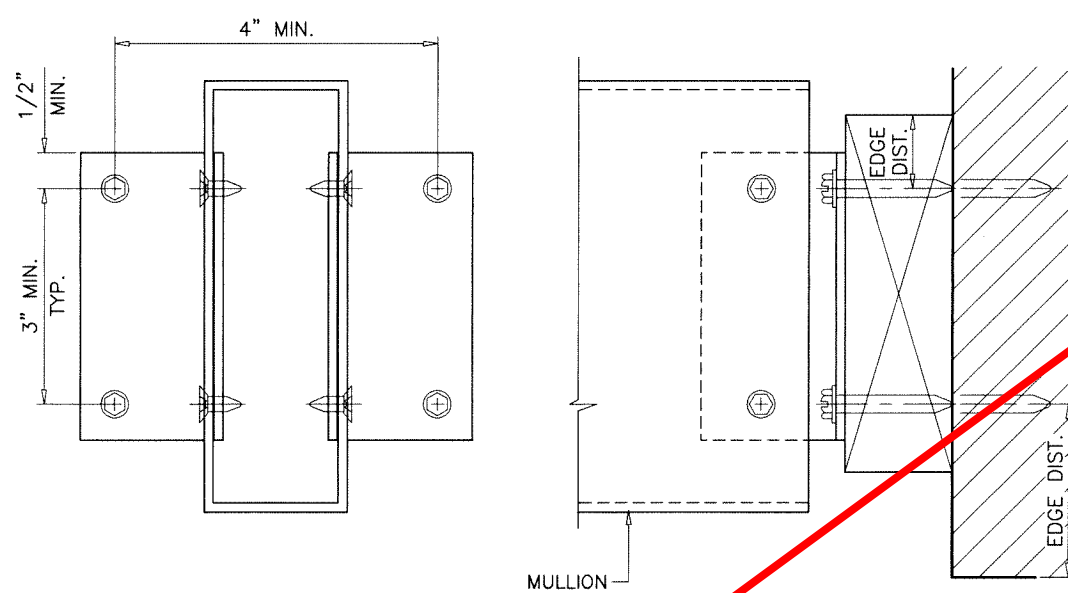

TYPICAL ANCHORS TYPE 'W4A'
 INTO 2BY WOOD BUCKS OR WOOD STRUCTURES
 THRU 1BY BUCKS INTO CONC. OR MASONRY
 SEE SHEET 12 FOR 'T' CLIP ANCHOR CAPACITIES
 SEE SHEET 12.1 FOR 'F' CLIP ANCHOR CAPACITIES



Sealed: 7/21/2023

FL #40673

af c
AL-FAROOQ CORPORATION
 ENGINEERS & PRODUCT DEVELOPMENT
 9360 SUNSET DRIVE, SUITE 220
 MIAMI, FLORIDA 33173
 TEL. (305) 264-8100 WWW.AFCENG.COM
 FBPE #8538 MULLION 21-75F-MG

EXTRUDED ALUMINUM CLIPPED MULLIONS
MR-GLASS DOORS & WINDOWS MANUFACTURING, LLC
 8051 N.W. 79th Place
 Medley, FL. 33166
 Tel. (305) 764-3963 www.mrglasswindows.com

revisions:	no	date	by	description

date: 12-21-21
 scale: 3/8" = 1"
 dr. by: TARIQ
 chk. by:

drawing no.
21-75F
 sheet 10 of 17

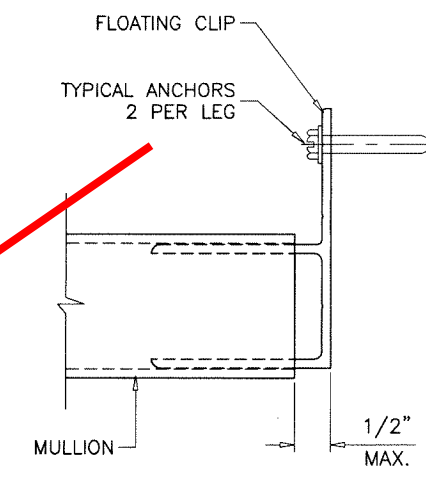
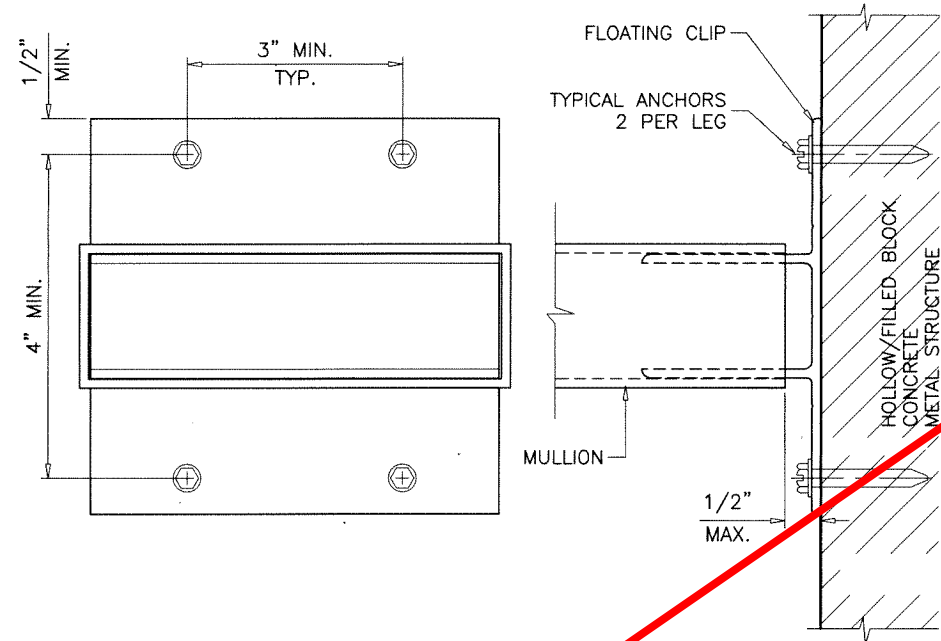
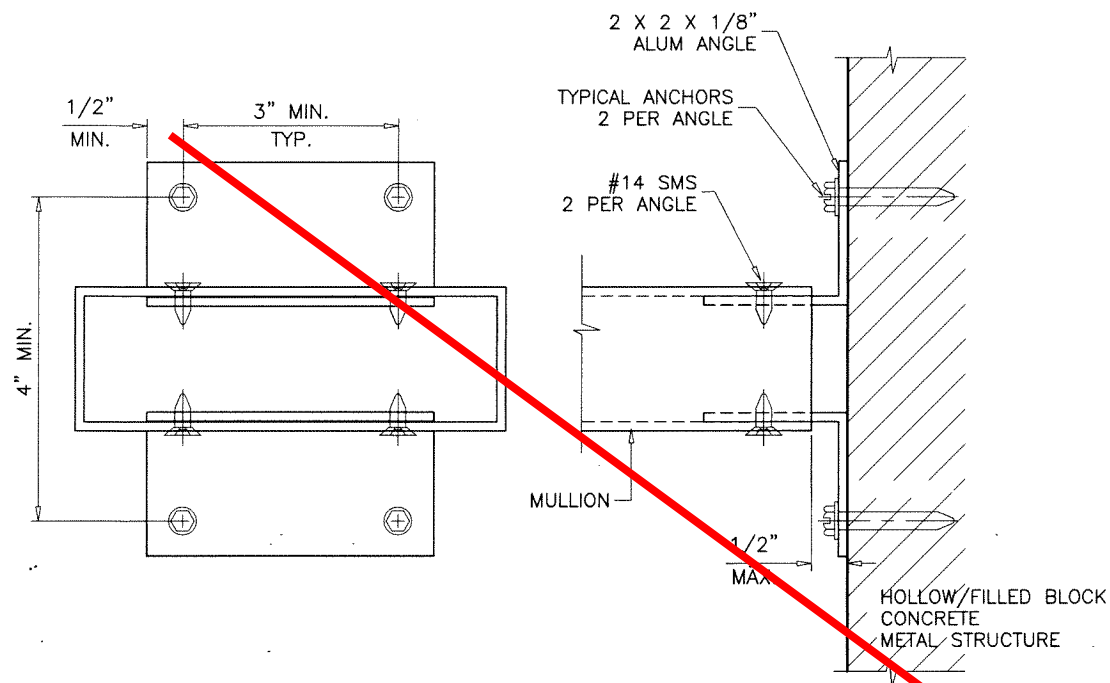

'F' CLIP DETAIL
 APPLICABLE TO ALL SUBSTRATES
 SHOWN FOR 'T' CLIP

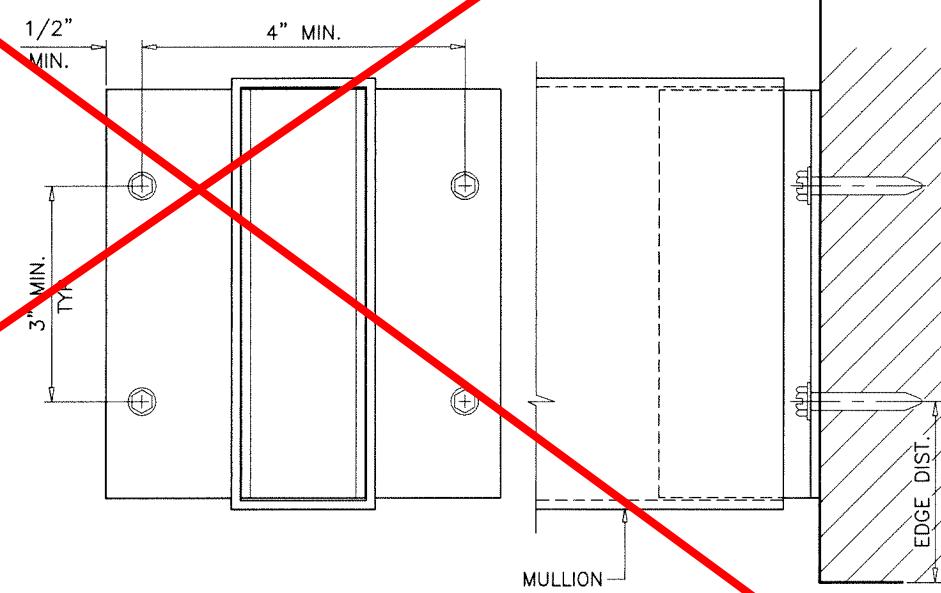
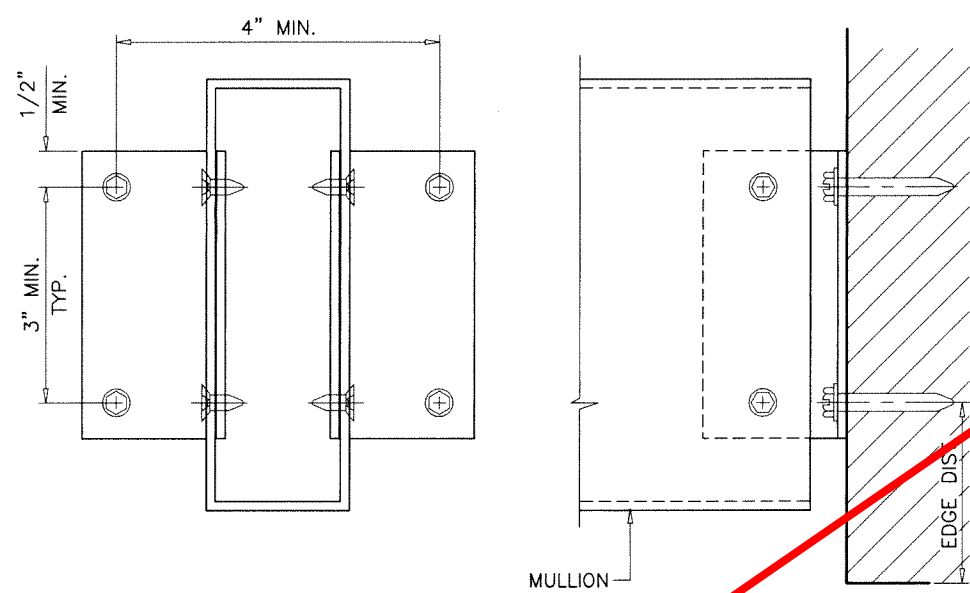

TYPICAL ANCHORS TYPE 'B4A', 'C4A', 'M4A'
 DIRECTLY INTO HOLLOW/FILLED BLOCK
 DIRECTLY INTO CONCRETE
 INTO METAL STRUCTURES

SEE SHEET 12 FOR 'T' CLIP ANCHOR CAPACITIES
 SEE SHEET 12.1 FOR 'F' CLIP ANCHOR CAPACITIES

afC
AL-FAROOQ CORPORATION
 ENGINEERS & PRODUCT DEVELOPMENT
 9360 SUNSET DRIVE, SUITE 220
 MIAMI, FLORIDA 33173
 TEL. (305) 264-8100 WWW.AFCENG.COM
 FBPE #8598 MULLION\21-75F-MG

EXTRUDED ALUMINUM CLIPPED MULLIONS
MR-GLASS DOORS & WINDOWS MANUFACTURING, LLC
 8051 N.W. 79th Place
 Medley, FL. 33166
 Tel. (305) 764-3963 www.mrglasswindows.com

revisions:	
no	date by description

date: 12-21-21	scale: 3/8" = 1"	dr. by: TARIQ	chk. by:
----------------	------------------	---------------	----------

drawing no.
21-75F
 sheet 11 of 17

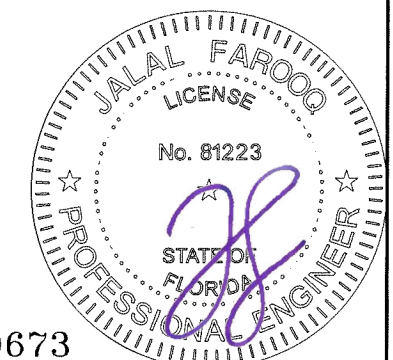

Sealed: 7/21/2023

FL #40673

DESIGN LOAD CAPACITY - PSF					
WINDOW DIMS.		ANCHORS TYPE			
WIDTH (W)	MULL SPAN	W4AT	B4AT	C4AT	M4AT
19-1/8"	38-3/8"	150.0	150.0	150.0	150.0
26-1/2"		150.0	150.0	150.0	150.0
30"		150.0	150.0	150.0	150.0
37"		150.0	150.0	150.0	150.0
42"		150.0	150.0	150.0	150.0
48"		150.0	150.0	150.0	150.0
54"		146.8	150.0	150.0	150.0
60"		132.1	145.1	150.0	150.0
66"		120.1	131.9	150.0	150.0
72"		110.1	120.9	150.0	150.0
19-1/8"	50-5/8"	150.0	150.0	150.0	150.0
26-1/2"		150.0	150.0	150.0	150.0
30"		150.0	150.0	150.0	150.0
37"		150.0	150.0	150.0	150.0
42"		143.0	150.0	150.0	150.0
48"		125.2	137.5	150.0	150.0
54"		111.2	122.2	150.0	150.0
60"		100.1	110.0	150.0	148.3
66"		91.0	100.0	147.2	134.8
72"		83.4	91.7	135.0	123.6
19-1/8"	63"	150.0	150.0	150.0	150.0
26-1/2"		150.0	150.0	150.0	150.0
30"		150.0	150.0	150.0	150.0
37"		130.5	143.3	150.0	150.0
42"		114.9	126.3	150.0	150.0
48"		100.6	110.5	150.0	149.0
54"		89.4	98.2	144.6	132.4
60"		80.5	88.4	130.1	119.2
66"		73.1	80.3	118.3	108.3
72"		67.0	73.7	108.4	99.3
19-1/8"	74-1/4"	150.0	150.0	150.0	150.0
26-1/2"		150.0	150.0	150.0	150.0
30"		136.5	150.0	150.0	150.0
37"		110.7	121.6	150.0	150.0
42"		97.5	107.1	150.0	144.4
48"		85.3	93.7	138.0	126.4
54"		75.9	83.3	122.7	112.3
60"		68.3	75.0	110.4	101.1
66"		62.1	68.2	100.4	91.9
72"		56.9	62.5	92.0	84.3
19-1/8"	76"	150.0	150.0	150.0	150.0
26-1/2"		150.0	150.0	150.0	150.0
30"		133.4	146.5	150.0	150.0
37"		108.2	118.8	150.0	150.0
42"		95.3	104.7	150.0	141.1
48"		83.4	91.6	134.8	123.5
54"		74.1	81.4	119.9	109.8
60"		66.7	73.7	107.9	98.8
66"		60.6	66.6	98.1	89.8
72"		55.6	61.1	89.9	82.3

DESIGN LOAD CAPACITY - PSF					
WINDOW DIMS.		ANCHORS TYPE			
WIDTH (W)	MULL SPAN	W4AT	B4AT	C4AT	M4AT
19-1/8"	84"	150.0	150.0	150.0	150.0
26-1/2"		136.6	150.0	150.0	150.0
30"		120.7	132.6	150.0	150.0
37"		97.9	107.5	150.0	144.9
42"		86.2	94.7	139.4	127.7
48"		75.4	82.9	122.0	111.7
54"		67.0	73.7	108.4	99.3
60"		60.3	66.3	97.6	89.4
66"		54.9	60.3	88.7	81.2
72"		50.3	55.2	81.3	74.5
19-1/8"	96"	150.0	150.0	150.0	150.0
26-1/2"		119.5	131.3	150.0	150.0
30"		105.6	116.0	150.0	150.0
37"		85.6	94.1	138.5	126.8
42"		75.4	82.9	122.0	111.7
48"		66.0	72.5	106.8	97.8
54"		58.7	64.1	94.9	86.9
60"		52.8	58.0	85.4	78.2
66"		48.0	52.7	77.0	71.1
72"		44.0	48.3	71.2	65.2
19-1/8"	108"	147.2	150.0	150.0	150.0
26-1/2"		106.3	116.7	150.0	150.0
30"		93.9	103.1	150.0	139.0
37"		76.1	83.6	123.1	112.7
42"		67.0	73.7	108.4	99.3
48"		58.7	64.4	94.9	86.9
54"		52.1	57.3	84.3	77.2
60"		46.9	51.6	75.9	69.5
66"		42.7	46.9	69.0	63.2
72"		39.1	43.0	63.3	57.9
19-1/8"	120"	132.5	145.6	150.0	150.0
26-1/2"		95.6	105.1	150.0	141.8
30"		84.5	92.8	136.6	125.1
37"		68.5	75.2	116.8	101.4
42"		60.3	66.3	97.6	89.4
48"		52.8	58.0	85.4	78.2
54"		46.9	51.6	75.9	69.5
60"		42.2	46.4	68.3	62.6
66"		38.4	42.2	62.1	56.9
72"		35.2	38.7	56.9	52.1
19-1/8"	132"	120.5	132.3	150.0	150.0
26-1/2"		86.9	95.5	140.6	128.8
30"		76.8	84.4	124.2	113.7
37"		62.3	68.4	100.7	92.2
42"		54.9	60.3	88.7	81.2
48"		48.0	52.7	77.6	71.1
54"		42.7	46.9	69.0	63.2
60"		38.4	42.2	62.1	56.9
66"		34.9	38.3	56.5	51.7
72"		32.0	35.2	51.8	47.4

DESIGN LOAD CAPACITY - PSF					
WINDOW DIMS.		ANCHORS TYPE			
WIDTH (W)	MULL SPAN	W4AT	B4AT	C4AT	M4AT
19-1/8"	144"	110.4	121.3	150.0	150.0
26-1/2"		79.7	87.5	128.9	118.0
30"		70.4	77.3	113.9	104.3
37"		57.1	62.7	92.3	84.5
42"		50.3	55.2	81.3	74.5
48"		44.0	48.3	71.2	65.2
54"		39.1	43.0	63.3	57.9
60"		35.2	38.7	56.9	52.1
66"		32.0	35.2	51.8	47.4
72"		29.3	32.2	47.4A	43.4
19-1/8"	156"	101.9	112.0	150.0	150.0
26-1/2"		73.6	80.8	119.0	109.0
30"		65.0	71.4	105.1	96.2
37"		52.7	57.9	85.2	78.0
42"		46.4	51.0	75.1	68.7
48"		40.6	44.6	65.7	60.2
54"		36.1	39.7	58.4	53.5
60"		32.5	35.7	52.6	48.1
66"		29.5	32.4	47.8	43.7
72"		27.1	29.7	43.8	40.1
19-1/8"	168"	94.7	104.0	150.0	140.2
26-1/2"		68.3	75.0	110.5	101.2
30"		60.3	66.5	97.6	89.4
37"		48.9	53.7	79.1	72.5
42"		43.1	47.3	69.7	63.8
48"		37.7	41.4	61.0	55.9
54"		33.5	36.8	54.2	49.7
60"		30.2	33.1	48.8	44.7
66"		27.4	30.1	44.4	40.6
72"		25.1	27.6	40.7	37.2

TYPICAL ANCHORS AT 'T' CLIP:

1/4" DIA. ULTRACON+ BY 'DEWALT' (Fu=164 KSI, Fy=148 KSI)

W4AT: INTO 2BY WOOD BUCKS OR WOOD STRUCTURES
1-1/2" MIN. PENETRATION INTO WOOD

W4AT: THRU 1BY BUCKS INTO CONCRETE OR BLOCKS
1-1/4" MIN. EMBED INTO CONCRETE OR BLOCKS

B4AT: DIRECTLY INTO HOLLOW/FILLED BLOCKS
1-1/4" MIN. EMBED INTO BLOCK

C4AT: DIRECTLY INTO CONCRETE
1-3/4" MIN. EMBED INTO CONCRETE

#14 SMS OR SELF-DRILLING SCREWS (GRADE 2 CRS)

M4AT: INTO METAL STRUCTURES
(3) THREADS MIN. TO EXTEND BEYOND METAL THICKNESS
ALUMINUM: 1/8" THK. MIN. (6063-T5 MIN.)
STEEL: 1/8" THK. MIN. (Fy = 36 KSI MIN.)
(STEEL IN CONTACT WITH ALUMINUM TO BE PLATED OR PAINTED)

TYPICAL EDGE DISTANCE

INTO CONCRETE AND BLOCKS = 2-1/2" MIN.
INTO WOOD STRUCTURE = 1" MIN.
INTO METAL STRUCTURE = 3/4" MIN.

WOOD AT HEAD, SILL OR JAMBS SG = 0.55 MIN.
CONCRETE AT HEAD, SILL OR JAMBS f'c = 3000 PSI MIN.
C-90 HOLLOW/FILLED NORMAL WEIGHT BLOCK AT JAMBS f'm = 2000 PSI MIN.

ANCHORS MAY BE HEX OR FLAT HEAD

NOTE:
ANY ANCHOR CONDITION SHOWN HEREIN MAY COVER LOCATIONS
AT HEAD, SILL OR JAMB ENDS.
SEE SHEETS 10 & 11 FOR ANCHOR DETAILS.

(INTERPOLATION BETWEEN WIDTHS OR SPANS ALLOWED)

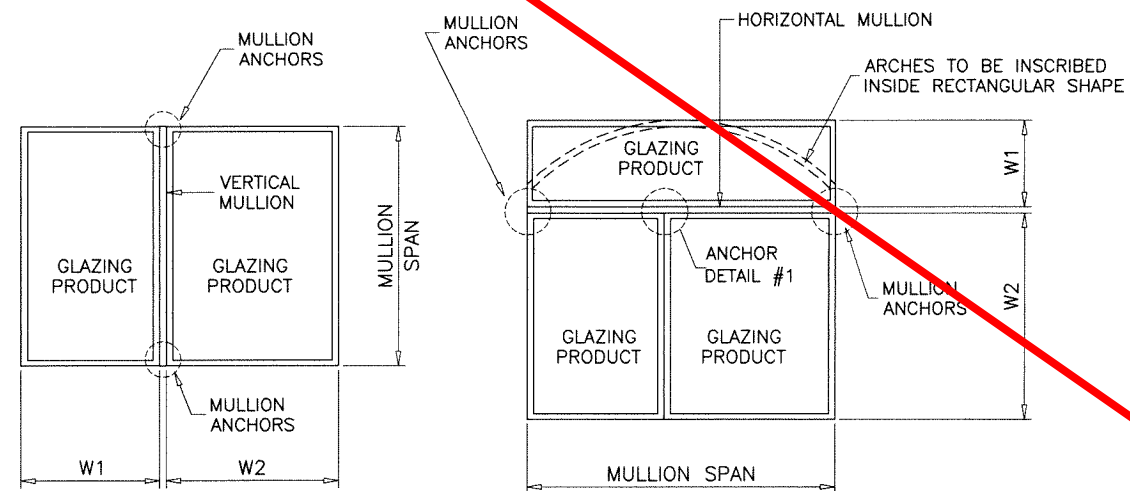

TYPICAL MULLION ARRANGEMENTS

$$\text{WIDTH (W)} = \frac{W1 + W2}{2}$$

ALL LOADS ARE EXT.(+)/INT.(-).

Sealed: 7/21/2023

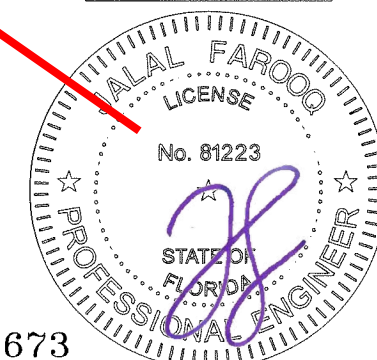

afC
AL-FAROOQ CORPORATION
ENGINEERS & PRODUCT DEVELOPMENT
9360 SUNSET DRIVE, SUITE 220
MIAMI, FLORIDA 33173
TEL. (305) 264-8100
WWW.AFCENG.COM
FBPE #8538

EXTRUDED ALUMINUM CLIPPED MULLIONS
MR-GLASS DOORS & WINDOWS MANUFACTURING, LLC
8051 N.W. 79th Place
Medley, FL. 33166
Tel. (305) 764-3963
www.mrglasswindows.com

revisions:	no	date	by	description
date:	12-21-21			
scale:	-			
dr. by:	TARIQ			
chk. by:				
drawing no.	21-75F			
sheet	12 of 17			

DESIGN LOAD CAPACITY - PSF					
WINDOW DIMS.		ANCHORS TYPE			
WIDTH (W)	MULL SPAN	W2AF	B2AF	C2AF	M2AF
19-1/8"	38-3/8"	150.0	150.0	150.0	150.0
26-1/2"		149.5	150.0	150.0	150.0
30"		132.1	145.1	150.0	150.0
37"		107.1	117.6	150.0	150.0
42"		94.3	103.6	150.0	139.7
48"		82.6	90.7	133.5	122.3
54"		73.4	80.6	118.7	108.7
60"		66.0	72.5	106.8	97.8
66"		60.0	66.0	97.1	88.0
72"		55.0	60.5	89.0	81.5
19-1/8"	50-5/8"	150.0	150.0	150.0	150.0
26-1/2"		113.3	124.5	150.0	150.0
30"		100.1	110.0	150.0	148.3
37"		81.2	89.2	131.3	120.2
42"		71.5	78.6	115.7	105.9
48"		62.6	68.7	101.2	92.7
54"		55.6	61.1	90.0	82.4
60"		50.1	55.0	81.0	74.1
66"		45.5	50.0	73.6	67.4
72"		41.7	45.8	67.5	61.8
19-1/8"	63"	126.2	138.6	150.0	150.0
26-1/2"		91.1	100.1	147.3	134.9
30"		80.5	88.4	130.1	119.2
37"		65.2	71.7	105.5	96.6
42"		57.5	63.1	93.0	85.1
48"		50.3	55.2	81.3	74.5
54"		44.7	49.1	72.3	66.2
60"		40.2	44.2	65.1	59.6
66"		36.6	40.2	59.2	54.2
72"		33.5	36.8	54.2	49.7
19-1/8"	74-1/4"	107.1	117.6	150.0	150.0
26-1/2"		77.3	84.9	125.0	114.5
30"		68.3	75.0	110.4	101.1
37"		55.4	60.8	89.5	82.0
42"		48.8	53.6	78.9	72.2
48"		42.7	46.9	69.0	63.2
54"		37.9	41.7	61.3	56.2
60"		34.1	37.5	55.2	50.6
66"		31.0	34.1	50.2	46.0
72"		28.4	31.2	46.0	42.1
19-1/8"	76"	104.6	114.9	150.0	150.0
26-1/2"		75.5	82.9	122.1	111.8
30"		66.7	73.3	107.9	98.8
37"		54.1	59.4	87.5	80.1
42"		47.6	52.3	77.1	70.6
48"		41.7	45.8	67.4	61.7
54"		37.1	40.7	59.9	54.9
60"		33.3	36.6	53.9	49.4
66"		30.3	33.3	49.0	44.9
72"		27.8	30.5	44.9	41.2

DESIGN LOAD CAPACITY - PSF					
WINDOW DIMS.		ANCHORS TYPE			
WIDTH (W)	MULL SPAN	W2AF	B2AF	C2AF	M2AF
19-1/8"	84"	94.7	104.0	150.0	140.2
26-1/2"		68.3	75.0	110.5	101.2
30"		60.3	66.3	97.6	89.4
37"		48.9	53.7	79.1	72.5
42"		43.1	47.3	69.7	63.8
48"		37.7	41.4	61.0	55.9
54"		33.5	36.8	54.2	49.7
60"		30.2	33.1	48.8	44.7
66"		27.4	30.1	44.4	40.6
72"		25.1	27.6	40.7	37.2
19-1/8"	96"	82.8	91.0	134.0	122.7
26-1/2"		59.8	65.7	96.7	88.5
30"		52.8	58.0	85.4	78.2
37"		42.8	47.0	69.2	63.4
42"		37.7	41.4	61.0	55.9
48"		33.7	36.3	53.4	48.9
54"		29.3	32.2	47.4	43.4
60"		26.4	29.0	42.7	39.1
66"		24.0	26.4	38.8	35.5
72"		22.0	24.2	35.6	32.6
19-1/8"	108"	73.6	80.9	119.1	109.0
26-1/2"		53.1	58.4	85.9	78.7
30"		46.9	51.6	75.9	69.5
37"		38.1	41.8	61.5	56.4
42"		33.5	36.8	54.2	49.7
48"		29.3	32.2	47.4	43.4
54"		26.1	28.6	42.2	38.6
60"		23.5	25.8	38.0	34.8
66"		21.3	23.4	34.5	31.6
72"		-	21.5	31.5	29.0
19-1/8"	120"	66.3	72.8	107.2	98.1
26-1/2"		47.8	52.5	77.3	70.8
30"		42.2	46.4	68.3	62.6
37"		34.2	37.6	55.4	50.7
42"		30.2	33.1	48.8	44.7
48"		26.4	29.0	42.7	39.1
54"		23.5	25.8	38.0	34.8
60"		21.1	23.2	34.2	31.3
66"		-	21.1	31.1	28.4
72"		-	-	28.5	26.1
19-1/8"	132"	60.2	66.2	97.4	89.2
26-1/2"		43.5	47.8	70.3	64.4
30"		38.4	42.2	62.1	56.9
37"		31.1	34.2	50.4	46.1
42"		27.4	30.1	44.4	40.6
48"		24.0	26.4	38.8	35.5
54"		21.3	23.4	34.5	31.6
60"		-	21.1	31.1	28.4
66"		-	-	28.2	25.9
72"		-	-	25.9	23.7

DESIGN LOAD CAPACITY - PSF					
WINDOW DIMS.		ANCHORS TYPE			
WIDTH (W)	MULL SPAN	W2AF	B2AF	C2AF	M2AF
19-1/8"	144"	55.2	60.7	89.3	81.8
26-1/2"		39.8	43.8	64.5	59.0
30"		35.2	38.7	56.9	52.1
37"		28.5	31.4	46.2	42.3
42"		25.1	27.6	40.7	37.2
48"		22.0	24.2	35.6	32.6
54"		-	21.5	31.6	29.0
60"		-	-	28.5	26.1
66"		-	-	25.9	23.7
72"		-	-	23.7	21.7
19-1/8"	156"	51.0	56.0	82.4	75.5
26-1/2"		36.8	40.4	59.5	54.5
30"		32.5	35.7	52.6	48.1
37"		26.3	28.9	42.6	39.0
42"		23.2	25.5	37.5	34.4
48"		20.3	22.3	32.8	30.1
54"		-	-	29.2	26.7
60"		-	-	26.5	24.1
66"		-	-	23.9	21.9
72"		-	-	21.9	20.1
19-1/8"	168"	47.3	52.0	76.5	70.1
26-1/2"		34.2	37.5	55.2	50.6
30"		30.2	33.1	48.8	44.7
37"		24.5	26.9	39.6	36.2
42"		21.6	23.7	34.9	31.9
48"		-	20.7	30.5	27.9
54"		-	-	27.1	24.8
60"		-	-	24.4	22.3
66"		-	-	22.2	20.3
72"		-	-	20.3	-

TYPICAL ANCHORS AT 'F' CLIP:

1/4" DIA. ULTRACON+ BY 'DEWALT' (Fu=164 KSI, Fy=148 KSI)

W2AF: INTO 2BY WOOD BUCKS OR WOOD STRUCTURES
1-1/2" MIN. PENETRATION INTO WOOD

W2AF: THRU 1BY BUCKS INTO CONCRETE OR BLOCKS
1-1/4" MIN. EMBED INTO CONCRETE OR BLOCKS

B2AF: DIRECTLY INTO HOLLOW/FILLED BLOCKS
1-1/4" MIN. EMBED INTO BLOCK

C2AF: DIRECTLY INTO CONCRETE
1-3/4" MIN. EMBED INTO CONCRETE

#14 SMS OR SELF-DRILLING SCREWS (GRADE 2 CRS)

M2AF: INTO METAL STRUCTURES
(3) THREADS MIN. TO EXTEND BEYOND METAL THICKNESS
ALUMINUM: 1/8" THK. MIN. (6063-T5 MIN.)
STEEL: 1/8" THK. MIN. (Fy = 36 KSI MIN.)
(STEEL IN CONTACT WITH ALUMINUM TO BE PLATED OR PAINTED)

TYPICAL EDGE DISTANCE

INTO CONCRETE AND BLOCKS = 2-1/2" MIN.
INTO WOOD STRUCTURE = 1" MIN.
INTO METAL STRUCTURE = 3/4" MIN.

WOOD AT HEAD, SILL OR JAMBS SG = 0.55 MIN.
CONCRETE AT HEAD, SILL OR JAMBS f'c = 3000 PSI MIN.
C-90 HOLLOW/FILLED NORMAL WEIGHT BLOCK AT JAMBS f'm = 2000 PSI MIN.

ANCHORS MAY BE HEX OR FLAT HEAD

NOTE:
ANY ANCHOR CONDITION SHOWN HEREIN MAY COVER LOCATIONS
AT HEAD, SILL OR JAMB ENDS.
SEE SHEETS 10 & 11 FOR ANCHOR DETAILS.

(INTERPOLATION BETWEEN WIDTHS OR SPANS ALLOWED)

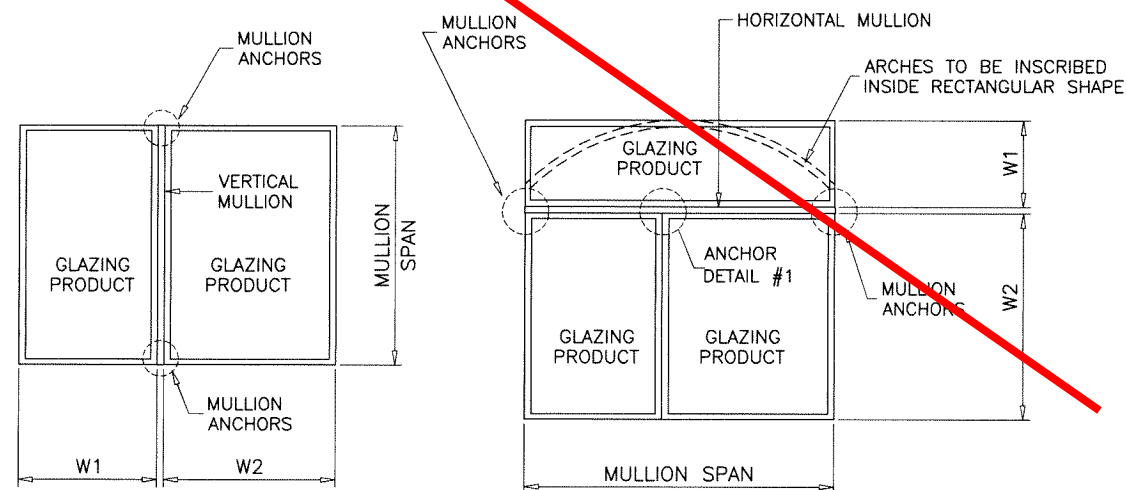

TYPICAL MULLION ARRANGEMENTS

$$\text{WIDTH (W)} = \frac{W1 + W2}{2}$$

Sealed: 7/21/2023

FL #40673

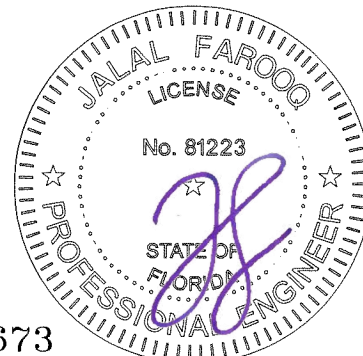

ALL LOADS ARE EXT.(+)/INT.(-).

AL-FAROOQ CORPORATION
ENGINEERS & PRODUCT DEVELOPMENT
9360 SUNSET DRIVE, SUITE 220
MIAMI, FLORIDA 33173
TEL: (305) 264-8100 WWW.AFCENG.COM
FBPE #3538

EXTRUDED ALUMINUM CLIPPED MULLIONS
MR-GLASS DOORS & WINDOWS MANUFACTURING, LLC
8051 N.W. 79th Place
Medley, FL. 33166
Tel. (305) 764-3963 www.mrglasswindows.com

revisions:	no.	date	description
date:	12-21-21	scale:	-
dr. by:	TARIO	chk. by:	
drawing no.	21-75F		
sheet	12.1 of 17		

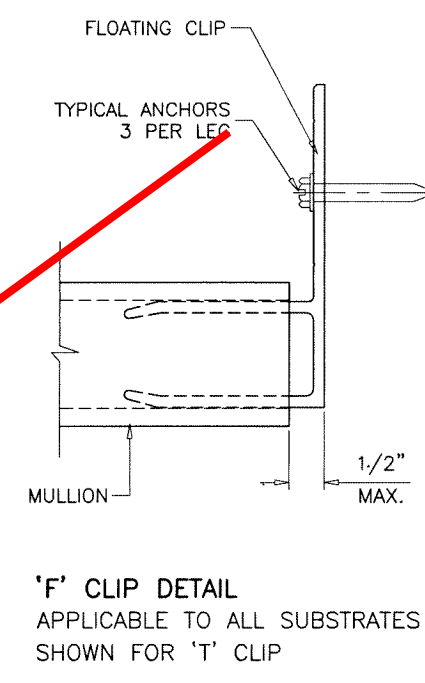
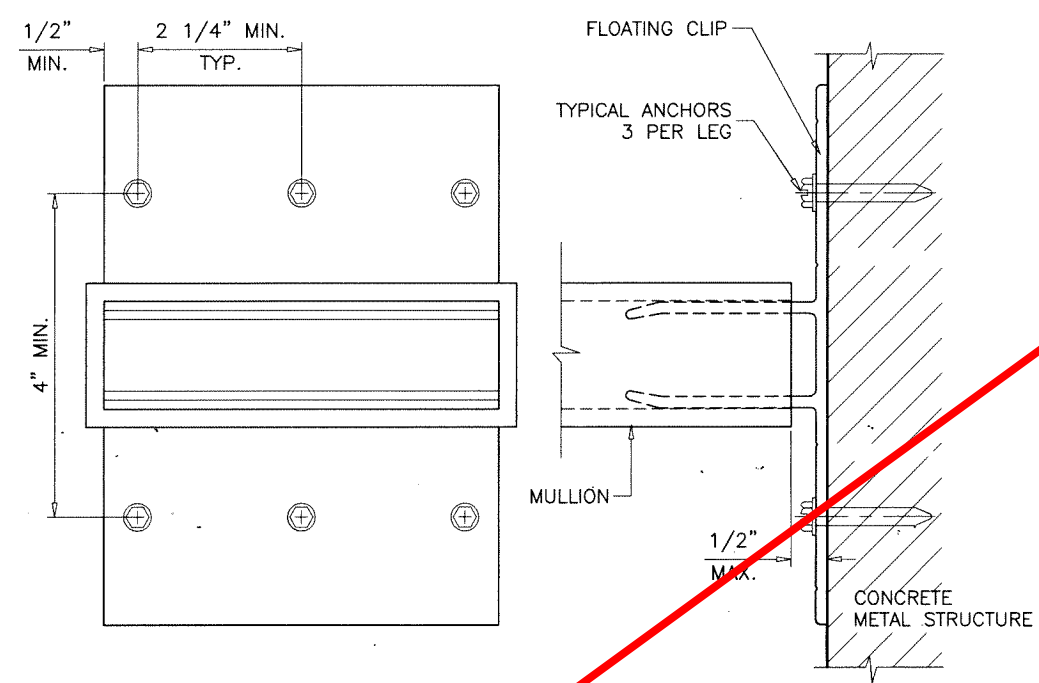
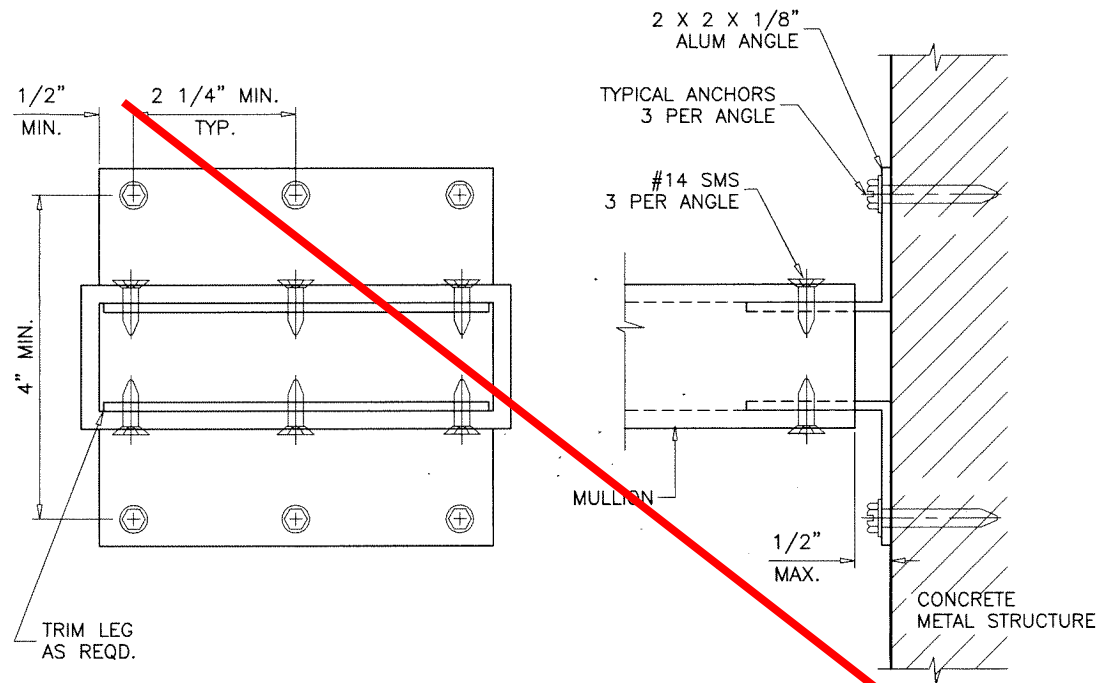

'F' CLIP DETAIL
 APPLICABLE TO ALL SUBSTRATES
 SHOWN FOR 'T' CLIP

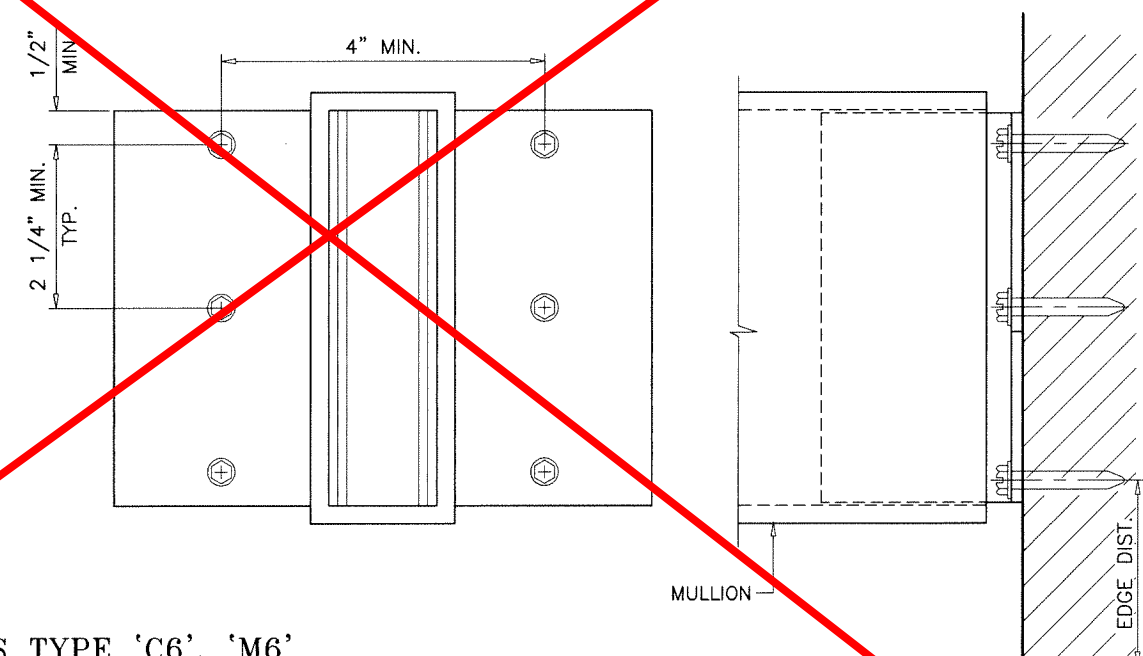

TYPICAL ANCHORS TYPE 'C6', 'M6'
 DIRECTLY INTO CONCRETE
 INTO METAL STRUCTURES
 SEE SHEET 14 FOR 'T' CLIP ANCHOR CAPACITIES
 SEE SHEET 14.1 FOR 'F' CLIP ANCHOR CAPACITIES

af c
AL-FAROOQ CORPORATION
 ENGINEERS & PRODUCT DEVELOPMENT
 9360 SUNSET DRIVE, SUITE 220
 MIAMI, FLORIDA 33173
 TEL. (305) 264-8100
 WWW.AFCENG.COM
 FBPE #3538
 MULLION\21-75F-MG

EXTRUDED ALUMINUM CLIPPED MULLIONS
MR-GLASS DOORS & WINDOWS MANUFACTURING, LLC
 8051 N.W. 79th Place
 Medley, FL. 33166
 Tel. (305) 764-3963
 www.mrglasswindows.com

revisions:	no	date	by	description

date: 12-21-21
 scale: 3/8" = 1"
 dr. by: TARIQ
 chk. by:

drawing no.
21-75F
 sheet 13 of 17

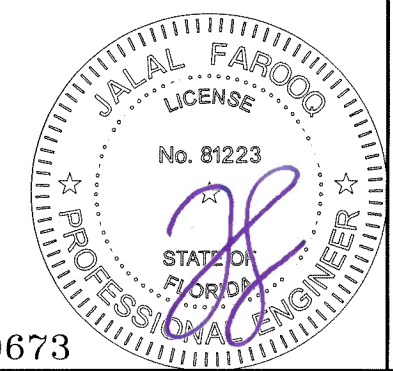

Sealed: 7/21/2023

FL #40673

DESIGN LOAD CAPACITY - PSF				DESIGN LOAD CAPACITY - PSF				DESIGN LOAD CAPACITY - PSF			
WINDOW DIMS.		ANCHORS TYPE		WINDOW DIMS.		ANCHORS TYPE		WINDOW DIMS.		ANCHORS TYPE	
WIDTH (W)	MULL SPAN	C6T	M6T	WIDTH (W)	MULL SPAN	C6T	M6T	WIDTH (W)	MULL SPAN	C6T	M6T
19-1/8"	38-3/8"	150.0	150.0	19-1/8"	84"	150.0	150.0	19-1/8"	144"	150.0	150.0
26-1/2"		150.0	150.0	26-1/2"		150.0	150.0	26-1/2"		150.0	150.0
30"		150.0	150.0	30"		150.0	150.0	30"		150.0	150.0
37"		150.0	150.0	37"		150.0	150.0	37"		137.2	126.8
42"		150.0	150.0	42"		150.0	150.0	42"		120.9	111.7
48"		150.0	150.0	48"		150.0	150.0	48"		105.8	97.8
54"		150.0	150.0	54"		150.0	149.0	54"		94.0	86.9
60"		150.0	150.0	60"		145.0	134.1	60"		84.6	78.2
66"	150.0	150.0	66"	131.8	121.9	66"	76.9	71.1			
72"	150.0	150.0	72"	120.9	111.7	72"	70.5	65.2			
19-1/8"	50-5/8"	150.0	150.0	19-1/8"	96"	150.0	150.0	19-1/8"	156"	150.0	150.0
26-1/2"		150.0	150.0	26-1/2"		150.0	150.0	26-1/2"		150.0	150.0
30"		150.0	150.0	30"		150.0	150.0	30"		150.0	144.4
37"		150.0	150.0	37"		150.0	150.0	37"		126.6	117.1
42"		150.0	150.0	42"		150.0	150.0	42"		111.6	103.1
48"		150.0	150.0	48"		150.0	146.6	48"		97.6	90.2
54"		150.0	150.0	54"		141.0	130.3	54"		86.8	80.2
60"		150.0	150.0	60"		126.9	117.3	60"		78.0	72.2
66"	150.0	150.0	66"	115.4	106.6	66"	71.0	65.6			
72"	150.0	150.0	72"	105.8	97.8	72"	65.1	60.2			
19-1/8"	63"	150.0	150.0	19-1/8"	108"	150.0	150.0	19-1/8"	168"	150.0	150.0
26-1/2"		150.0	150.0	26-1/2"		150.0	150.0	26-1/2"		150.0	150.0
30"		150.0	150.0	30"		150.0	150.0	30"		145.0	134.1
37"		150.0	150.0	37"		150.0	150.0	37"		117.6	108.7
42"		150.0	150.0	42"		150.0	149.0	42"		103.6	95.8
48"		150.0	150.0	48"		141.0	130.3	48"		90.6	83.8
54"		150.0	150.0	54"		125.3	115.9	54"		80.6	74.5
60"		150.0	150.0	60"		112.8	104.3	60"		72.5	67.0
66"	150.0	150.0	66"	102.5	94.8	66"	65.9	60.9			
72"	150.0	149.0	72"	94.0	86.9	72"	60.4	55.9			
19-1/8"	74-1/4"	150.0	150.0	19-1/8"	120"	150.0	150.0	19-1/8"	180"	150.0	150.0
26-1/2"		150.0	150.0	26-1/2"		150.0	150.0	26-1/2"		150.0	150.0
30"		150.0	150.0	30"		150.0	150.0	30"		150.0	150.0
37"		150.0	150.0	37"		150.0	150.0	37"		150.0	150.0
42"		150.0	150.0	42"		145.0	134.1	42"		145.0	134.1
48"		150.0	150.0	48"		126.9	117.3	48"		126.9	117.3
54"		150.0	150.0	54"		112.8	104.3	54"		112.8	104.3
60"		150.0	150.0	60"		101.5	93.8	60"		101.5	93.8
66"	149.2	137.9	66"	92.3	85.3	66"	92.3	85.3			
72"	136.7	126.4	72"	84.6	78.2	72"	84.6	78.2			
19-1/8"	76"	150.0	150.0	19-1/8"	132"	150.0	150.0	19-1/8"	192"	150.0	150.0
26-1/2"		150.0	150.0	26-1/2"		150.0	150.0	26-1/2"		150.0	150.0
30"		150.0	150.0	30"		150.0	150.0	30"		150.0	150.0
37"		150.0	150.0	37"		149.7	138.3	37"		149.7	138.3
42"		150.0	150.0	42"		131.8	121.9	42"		131.8	121.9
48"		150.0	150.0	48"		115.4	106.6	48"		115.4	106.6
54"		150.0	150.0	54"		102.5	94.8	54"		102.5	94.8
60"		150.0	148.2	60"		92.3	85.3	60"		92.3	85.3
66"	145.7	134.7	66"	83.9	77.6	66"	83.9	77.6			
72"	133.6	123.5	72"	76.9	71.1	72"	76.9	71.1			

ALL LOADS ARE EXT.(+)/INT.(-).

TYPICAL ANCHORS AT 'T' CLIP:

1/4" DIA. ULTRACON+ BY 'DEWALT' (Fu=164 KSI, Fy=148 KSI)

C6T: DIRECTLY INTO CONCRETE
1-3/4" MIN. EMBED INTO CONCRETE

#14 SMS OR SELF-DRILLING SCREWS (GRADE 2 CRS)

M6T: INTO METAL STRUCTURES
(3) THREADS MIN. TO EXTEND BEYOND METAL THICKNESS
ALUMINUM: 1/8" THK. MIN. (6063-T5 MIN.)
STEEL: 1/8" THK. MIN. (Fy = 36 KSI MIN.)
(STEEL IN CONTACT WITH ALUMINUM TO BE PLATED OR PAINTED)

TYPICAL EDGE DISTANCE

INTO CONCRETE = 2-1/2" MIN.
INTO METAL STRUCTURE = 3/4" MIN.

CONCRETE AT HEAD, SILL OR JAMBS f'c = 3000 PSI MIN.

ANCHORS MAY BE HEX OR FLAT HEAD

NOTE:
ANY ANCHOR CONDITION SHOWN HEREIN MAY COVER LOCATIONS
AT HEAD, SILL OR JAMB ENDS.
SEE SHEET 13 FOR ANCHOR DETAILS.

(INTERPOLATION BETWEEN WIDTHS OR SPANS ALLOWED)

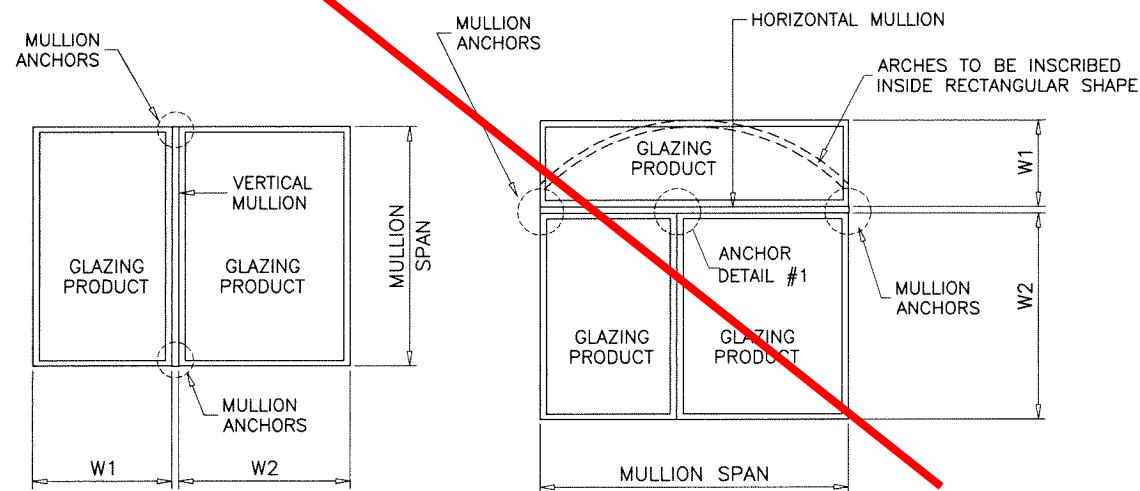

TYPICAL MULLION ARRANGEMENTS

$$\text{WIDTH (W)} = \frac{W1 + W2}{2}$$

Sealed: 7/21/2023

FL #40673

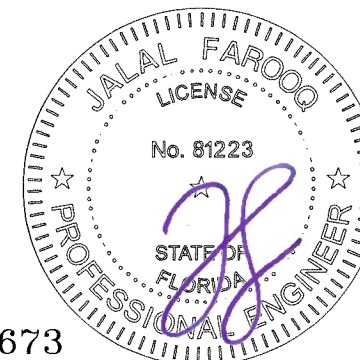

a f c
AL-FAROOQ CORPORATION
 ENGINEERS & PRODUCT DEVELOPMENT
 9360 SUNSET DRIVE, SUITE 220
 MIAMI, FLORIDA 33173
 TEL. (305) 264-8100
 WWW.AFCENG.COM
 FBPE #3598

EXTRUDED ALUMINUM CLIPPED MULLIONS
MR-GLASS DOORS & WINDOWS MANUFACTURING, LLC
 8051 N.W. 79th Place
 Medley, FL. 33166
 Tel. (305) 764-3963
 www.mrglasswindows.com

revisions:	no	date	by	description
date:	12-21-21			
scale:	-			
dr. by:	TARIQ			
chk. by:				
drawing no.	21-75F			
sheet	14 of 17			

DESIGN LOAD CAPACITY - PSF				DESIGN LOAD CAPACITY - PSF				DESIGN LOAD CAPACITY - PSF			
WINDOW DIMS.		ANCHORS TYPE		WINDOW DIMS.		ANCHORS TYPE		WINDOW DIMS.		ANCHORS TYPE	
WIDTH (W)	MULL SPAN	C3F	M3F	WIDTH (W)	MULL SPAN	C3F	M3F	WIDTH (W)	MULL SPAN	C3F	M3F
19-1/8"	38-3/8"	150.0	150.0	19-1/8"	84"	150.0	150.0	19-1/8"	144"	132.7	122.7
26-1/2"		150.0	150.0	26-1/2"		150.0	150.0	26-1/2"		95.8	88.5
30"		150.0	150.0	30"		145.0	134.1	30"		84.5	78.2
37"		150.0	150.0	37"		117.6	108.7	37"		68.6	63.4
42"		150.0	150.0	42"		103.6	95.8	42"		60.4	55.9
48"		150.0	150.0	48"		90.6	83.8	48"		52.9	48.9
54"		150.0	150.0	54"		80.6	74.5	54"		47.0	43.4
60"		150.0	146.7	60"		72.5	67.0	60"		42.3	39.1
66"		144.3	133.4	66"		65.9	60.9	66"		38.5	35.5
72"		132.3	122.3	72"		60.4	55.9	72"		35.3	32.6
19-1/8"	50-5/8"	150.0	150.0	19-1/8"	96"	150.0	150.0	19-1/8"	156"	122.5	113.2
26-1/2"		150.0	150.0	26-1/2"		143.7	132.8	26-1/2"		88.4	81.7
30"		150.0	150.0	30"		126.9	117.3	30"		78.1	72.2
37"		150.0	150.0	37"		102.9	95.1	37"		63.3	58.5
42"		150.0	150.0	42"		90.6	83.8	42"		55.8	51.6
48"		150.0	139.0	48"		79.3	73.3	48"		48.8	45.1
54"		133.7	123.6	54"		70.5	65.2	54"		43.4	40.1
60"		120.3	111.2	60"		63.5	58.7	60"		39.0	36.1
66"		109.4	101.1	66"		57.7	53.3	66"		35.5	32.8
72"		100.3	92.7	72"		52.9	48.9	72"		32.5	30.1
19-1/8"	63"	150.0	150.0	19-1/8"	108"	150.0	150.0	19-1/8"	168"	113.7	105.1
26-1/2"		150.0	150.0	26-1/2"		127.7	118.0	26-1/2"		82.1	75.9
30"		150.0	150.0	30"		112.8	104.3	30"		72.5	67.0
37"		150.0	144.9	37"		91.5	84.5	37"		58.8	54.3
42"		138.1	127.7	42"		80.6	74.5	42"		51.8	47.9
48"		120.9	111.7	48"		70.5	65.2	48"		45.3	41.9
54"		107.4	99.3	54"		62.7	57.9	54"		40.3	37.2
60"		96.7	89.4	60"		56.4	52.1	60"		36.3	33.5
66"		87.9	81.2	66"		51.3	47.4	66"		33.0	30.5
72"		80.6	74.5	72"		47.0	43.4	72"		30.2	27.9
19-1/8"	74-1/4"	150.0	150.0	19-1/8"	120"	150.0	147.2	19-1/8"	180"	113.7	105.1
26-1/2"		150.0	150.0	26-1/2"		114.9	106.2	26-1/2"		82.1	75.9
30"		150.0	150.0	30"		101.5	93.8	30"		72.5	67.0
37"		133.0	123.0	37"		82.3	76.1	37"		58.8	54.3
42"		117.2	108.3	42"		72.5	67.0	42"		51.8	47.9
48"		102.5	94.8	48"		63.5	58.7	48"		45.3	41.9
54"		91.2	84.3	54"		56.4	52.1	54"		40.3	37.2
60"		82.0	75.8	60"		50.8	46.9	60"		36.3	33.5
66"		74.6	68.9	66"		46.1	42.7	66"		33.0	30.5
72"		68.4	63.2	72"		42.3	39.1	72"		30.2	27.9
19-1/8"	76"	150.0	150.0	19-1/8"	132"	144.8	133.8	19-1/8"	192"	113.7	105.1
26-1/2"		150.0	150.0	26-1/2"		104.5	96.6	26-1/2"		82.1	75.9
30"		150.0	148.2	30"		92.3	85.3	30"		72.5	67.0
37"		130.0	120.1	37"		74.8	69.2	37"		58.8	54.3
42"		114.5	105.8	42"		65.9	60.9	42"		51.8	47.9
48"		100.2	92.6	48"		57.7	53.3	48"		45.3	41.9
54"		89.1	82.3	54"		51.3	47.4	54"		40.3	37.2
60"		80.1	74.1	60"		46.1	42.7	60"		36.3	33.5
66"		72.9	67.3	66"		42.0	150.0	66"		33.0	30.5
72"		66.8	61.7	72"		38.5	150.0	72"		30.2	27.9

ALL LOADS ARE EXT.(+)/INT.(-).

TYPICAL ANCHORS AT 'F' CLIP:

1/4" DIA. ULTRACON+ BY 'DEWALT' (Fu=164 KSI, Fy=148 KSI)

C3F: DIRECTLY INTO CONCRETE
1-3/4" MIN. EMBED INTO CONCRETE

#14 SMS OR SELF-DRILLING SCREWS (GRADE 2 CRS)

M3F: INTO METAL STRUCTURES
(3) THREADS MIN. TO EXTEND BEYOND METAL THICKNESS
ALUMINUM: 1/8" THK. MIN. (6063-T5 MIN.)
STEEL: 1/8" THK. MIN. (Fy = 36 KSI MIN.)
(STEEL IN CONTACT WITH ALUMINUM TO BE PLATED OR PAINTED)

TYPICAL EDGE DISTANCE

INTO CONCRETE = 2-1/2" MIN.
INTO METAL STRUCTURE = 3/4" MIN.

CONCRETE AT HEAD, SILL OR JAMBS f'c = 3000 PSI MIN.

ANCHORS MAY BE HEX OR FLAT HEAD

NOTE:
ANY ANCHOR CONDITION SHOWN HEREIN MAY COVER LOCATIONS
AT HEAD, SILL OR JAMB ENDS.
SEE SHEET 13 FOR ANCHOR DETAILS.

(INTERPOLATION BETWEEN WIDTHS OR SPANS ALLOWED)

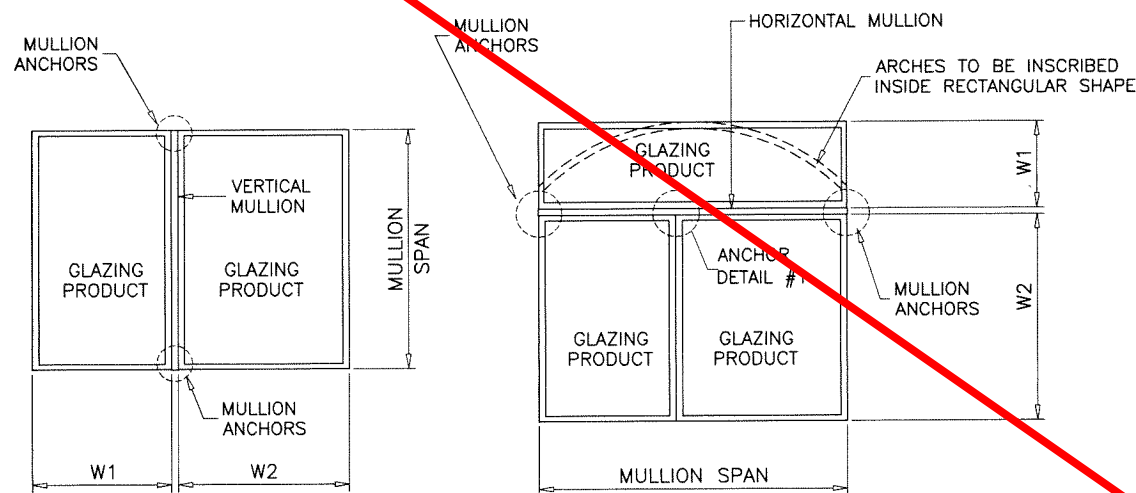

TYPICAL MULLION ARRANGEMENTS

$$\text{WIDTH (W)} = \frac{W1 + W2}{2}$$

Sealed: 7/21/2023

FL #40673

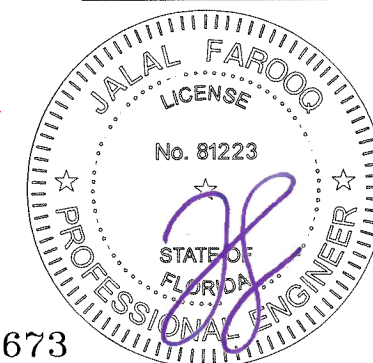

afC
AL-FAROOQ CORPORATION
 ENGINEERS & PRODUCT DEVELOPMENT
 9360 SUNSET DRIVE, SUITE 220
 MIAMI, FLORIDA 33173
 TEL. (305) 264-8100
 WWW.AFCENG.COM
 FBPE #3538
 MULLION 21-75F-MC

EXTRUDED ALUMINUM CLIPPED MULLIONS
MR-GLASS DOORS & WINDOWS MANUFACTURING, LLC
 8051 N.W. 79th Place
 Medley, FL. 33166
 Tel. (305) 764-3963
 www.mrglasswindows.com

revisions:
 no. date by description

date: 12-21-21
 scale: -
 dr. by: TARIQ
 chk. by:

drawing no.
21-75F

sheet 14.1 of 17

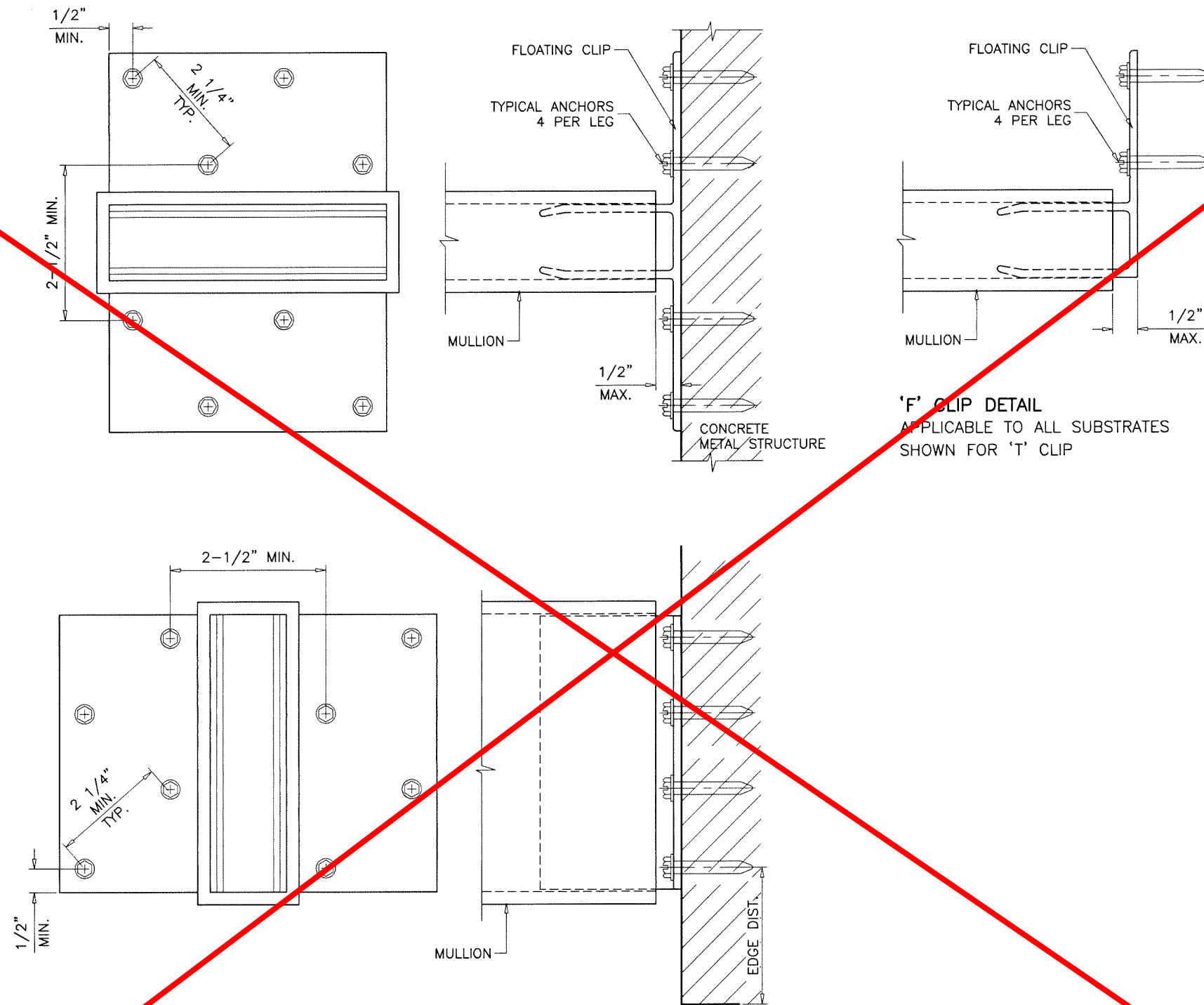

'F' CLIP DETAIL
 APPLICABLE TO ALL SUBSTRATES
 SHOWN FOR 'T' CLIP

TYPICAL ANCHORS TYPE 'C8', 'M8'
 DIRECTLY INTO CONCRETE
 INTO METAL STRUCTURES

SEE SHEET 16 FOR 'T' CLIP ANCHOR CAPACITIES
 SEE SHEET 16.1 FOR 'F' CLIP ANCHOR CAPACITIES

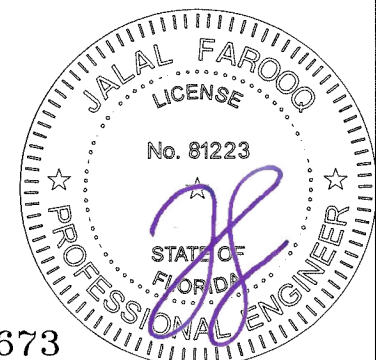

Sealed: 7/21/2023

FL #40673

afc

AL-FAROOQ CORPORATION
 ENGINEERS & PRODUCT DEVELOPMENT
 9360 SUNSET DRIVE, SUITE 220
 MIAMI, FLORIDA 33173
 TEL. (305) 264-8100
 WWW.AFCENG.COM
 FBPE #3538
 MULLION\21-75F-MG

EXTRUDED ALUMINUM CLIPPED MULLIONS

MR-GLASS DOORS & WINDOWS MANUFACTURING, LLC
 8051 N.W. 79th Place
 Medley, FL. 33166
 Tel. (305) 764-3963
 www.mrglasswindows.com

revisions:	no	date	description

date: 12-21-21
 scale: 3/8" = 1"
 dr. by: TARIQ
 chk. by:

drawing no.
21-75F

sheet 15 of 17

DESIGN LOAD CAPACITY - PSF				DESIGN LOAD CAPACITY - PSF				DESIGN LOAD CAPACITY - PSF			
WINDOW DIMS.		ANCHORS TYPE		WINDOW DIMS.		ANCHORS TYPE		WINDOW DIMS.		ANCHORS TYPE	
WIDTH (W)	MULL SPAN	C8T	M8T	WIDTH (W)	MULL SPAN	C8T	M8T	WIDTH (W)	MULL SPAN	C8T	M8T
19-1/8"	38-3/8"	150.0	150.0	19-1/8"	84"	150.0	150.0	19-1/8"	144"	150.0	150.0
26-1/2"		150.0	150.0	26-1/2"		150.0	150.0	26-1/2"		150.0	150.0
30"		150.0	150.0	30"		150.0	150.0	30"		150.0	150.0
37"		150.0	150.0	37"		150.0	150.0	37"		150.0	150.0
42"		150.0	150.0	42"		150.0	150.0	42"		150.0	149.0
48"		150.0	150.0	48"		150.0	150.0	48"		141.0	130.3
54"		150.0	150.0	54"		150.0	150.0	54"		125.3	115.9
60"		150.0	150.0	60"		150.0	150.0	60"		112.8	104.3
66"		150.0	150.0	66"		150.0	150.0	66"		102.5	94.8
72"		150.0	150.0	72"		150.0	149.0	72"		94.0	86.9
19-1/8"	50-5/8"	150.0	150.0	19-1/8"	96"	150.0	150.0	19-1/8"	156"	150.0	150.0
26-1/2"		150.0	150.0	26-1/2"		150.0	150.0	26-1/2"		150.0	150.0
30"		150.0	150.0	30"		150.0	150.0	30"		150.0	150.0
37"		150.0	150.0	37"		150.0	150.0	37"		150.0	150.0
42"		150.0	150.0	42"		150.0	150.0	42"		148.7	137.5
48"		150.0	150.0	48"		150.0	150.0	48"		130.2	120.3
54"		150.0	150.0	54"		150.0	150.0	54"		115.7	106.9
60"		150.0	150.0	60"		150.0	150.0	60"		104.1	96.2
66"		150.0	150.0	66"		150.0	142.2	66"		94.7	87.5
72"		150.0	150.0	72"		141.0	130.3	72"		86.8	80.2
19-1/8"	63"	150.0	150.0	19-1/8"	108"	150.0	150.0	19-1/8"	168"	150.0	150.0
26-1/2"		150.0	150.0	26-1/2"		150.0	150.0	26-1/2"		150.0	150.0
30"		150.0	150.0	30"		150.0	150.0	30"		150.0	150.0
37"		150.0	150.0	37"		150.0	150.0	37"		150.0	144.9
42"		150.0	150.0	42"		150.0	150.0	42"		138.1	127.7
48"		150.0	150.0	48"		150.0	150.0	48"		120.9	111.7
54"		150.0	150.0	54"		150.0	150.0	54"		107.4	99.3
60"		150.0	150.0	60"		150.0	139.0	60"		96.7	89.4
66"		150.0	150.0	66"		136.7	126.4	66"		87.9	81.2
72"		150.0	150.0	72"		125.3	115.9	72"		80.5	74.5
19-1/8"	74-1/4"	150.0	150.0	19-1/8"	120"	150.0	150.0	19-1/8"	180"	150.0	150.0
26-1/2"		150.0	150.0	26-1/2"		150.0	150.0	26-1/2"		150.0	150.0
30"		150.0	150.0	30"		150.0	150.0	30"		150.0	150.0
37"		150.0	150.0	37"		150.0	150.0	37"		150.0	150.0
42"		150.0	150.0	42"		150.0	150.0	42"		150.0	150.0
48"		150.0	150.0	48"		150.0	150.0	48"		150.0	150.0
54"		150.0	150.0	54"		150.0	139.0	54"		150.0	150.0
60"		150.0	150.0	60"		135.4	126.1	60"		150.0	150.0
66"		150.0	150.0	66"		123.1	113.7	66"		150.0	150.0
72"		150.0	150.0	72"		112.8	104.3	72"		150.0	150.0
19-1/8"	76"	150.0	150.0	19-1/8"	132"	150.0	150.0	19-1/8"	192"	150.0	150.0
26-1/2"		150.0	150.0	26-1/2"		150.0	150.0	26-1/2"		150.0	150.0
30"		150.0	150.0	30"		150.0	150.0	30"		150.0	150.0
37"		150.0	150.0	37"		150.0	150.0	37"		150.0	150.0
42"		150.0	150.0	42"		150.0	150.0	42"		150.0	150.0
48"		150.0	150.0	48"		150.0	142.2	48"		150.0	150.0
54"		150.0	150.0	54"		136.7	126.4	54"		150.0	150.0
60"		150.0	150.0	60"		123.1	113.7	60"		150.0	150.0
66"		150.0	150.0	66"		111.9	103.4	66"		150.0	150.0
72"		150.0	150.0	72"		102.5	94.8	72"		150.0	150.0

ALL LOADS ARE EXT.(+)/INT.(-).

TYPICAL ANCHORS AT 'T' CLIP:

1/4" DIA. ULTRACON+ BY 'DEWALT' (Fu=164 KSI, Fy=148 KSI)

C8T: DIRECTLY INTO CONCRETE
1-3/4" MIN. EMBED INTO CONCRETE

#14 SMS OR SELF-DRILLING SCREWS (GRADE 2 CRS)

M8T: INTO METAL STRUCTURES
(3) THREADS MIN. TO EXTEND BEYOND METAL THICKNESS
ALUMINUM: 1/8" THK. MIN. (6063-T5 MIN.)
STEEL: 1/8" THK. MIN. (Fy = 36 KSI MIN.)
(STEEL IN CONTACT WITH ALUMINUM TO BE PLATED OR PAINTED)

TYPICAL EDGE DISTANCE

INTO CONCRETE = 2-1/2" MIN.
INTO METAL STRUCTURE = 3/4" MIN.

CONCRETE AT HEAD, SILL OR JAMBS f'c = 3000 PSI MIN.

ANCHORS MAY BE HEX OR FLAT HEAD

NOTE:
ANY ANCHOR CONDITION SHOWN HEREIN MAY COVER LOCATIONS
AT HEAD, SILL OR JAMB ENDS.
SEE SHEET 15 FOR ANCHOR DETAILS.

(INTERPOLATION BETWEEN WIDTHS OR SPANS ALLOWED)

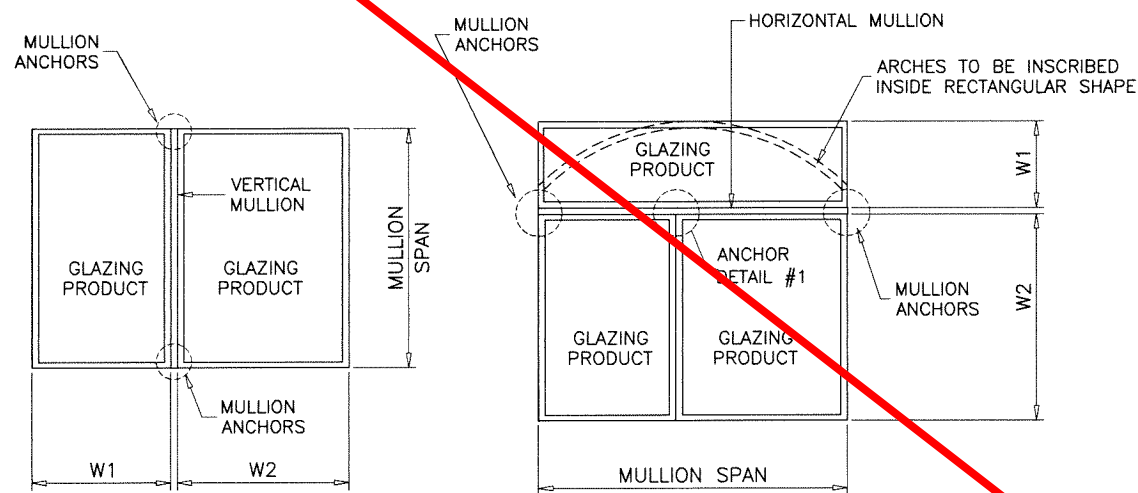

TYPICAL MULLION ARRANGEMENTS

$$\text{WIDTH (W)} = \frac{W1 + W2}{2}$$

Sealed: 7/21/2023

FL #40673

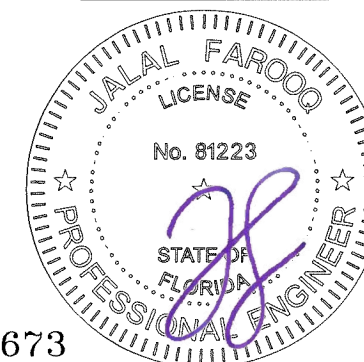

af c
AL-FAROOQ CORPORATION
 ENGINEERS & PRODUCT DEVELOPMENT
 9360 SUNSET DRIVE, SUITE 220
 MIAMI, FLORIDA 33173
 TEL. (305) 264-8100 WWW.AFCENG.COM
 MULLION\21-75F-MG
 FBPE #3538

EXTRUDED ALUMINUM CLIPPED MULLIONS
MR-GLASS DOORS & WINDOWS MANUFACTURING, LLC
 8051 N.W. 79th Place
 Medley, FL. 33166
 Tel. (305) 764-3963 www.mrglasswindows.com

revisions:	no	date	by	description

date: 12-21-21
 scale: -
 dr. by: TARIQ
 chk. by:

drawing no.
21-75F
 sheet 16 of 17

DESIGN LOAD CAPACITY - PSF				DESIGN LOAD CAPACITY - PSF				DESIGN LOAD CAPACITY - PSF			
WINDOW DIMS.		ANCHORS TYPE		WINDOW DIMS.		ANCHORS TYPE		WINDOW DIMS.		ANCHORS TYPE	
WIDTH (W)	MULL SPAN	C4F	M4F	WIDTH (W)	MULL SPAN	C4F	M4F	WIDTH (W)	MULL SPAN	C4F	M4F
19-1/8"	38-3/8"	150.0	150.0	19-1/8"	84"	150.0	150.0	19-1/8"	144"	150.0	150.0
26-1/2"		150.0	150.0	26-1/2"		150.0	150.0	26-1/2"		127.7	118.0
30"		150.0	150.0	30"		150.0	150.0	30"		112.8	104.3
37"		150.0	150.0	37"		150.0	144.9	37"		91.5	84.5
42"		150.0	150.0	42"		138.1	127.7	42"		80.6	74.5
48"		150.0	150.0	48"		120.9	111.7	48"		70.5	65.2
54"		150.0	150.0	54"		107.4	99.3	54"		62.7	57.9
60"		150.0	150.0	60"		96.7	89.4	60"		56.4	52.1
66"	150.0	150.0	66"	87.9	81.2	66"	51.3	47.4			
72"	150.0	150.0	72"	80.6	74.5	72"	47.0	43.4			
19-1/8"	50-5/8"	150.0	150.0	19-1/8"	96"	150.0	150.0	19-1/8"	156"	150.0	150.0
26-1/2"		150.0	150.0	26-1/2"		150.0	150.0	26-1/2"		117.9	109.0
30"		150.0	150.0	30"		150.0	150.0	30"		104.1	96.2
37"		150.0	150.0	37"		137.2	126.8	37"		84.4	78.0
42"		150.0	150.0	42"		120.9	111.7	42"		74.4	68.7
48"		150.0	150.0	48"		105.8	97.8	48"		65.1	60.2
54"		150.0	150.0	54"		94.0	86.9	54"		57.8	53.5
60"		150.0	148.3	60"		84.6	78.2	60"		52.1	48.1
66"	145.8	134.8	66"	76.9	71.1	66"	47.3	43.7			
72"	133.7	123.6	72"	70.5	65.2	72"	43.4	40.1			
19-1/8"	63"	150.0	150.0	19-1/8"	108"	150.0	150.0	19-1/8"	168"	150.0	140.2
26-1/2"		150.0	150.0	26-1/2"		150.0	150.0	26-1/2"		109.5	101.2
30"		150.0	150.0	30"		150.0	139.0	30"		96.7	89.4
37"		150.0	150.0	37"		121.9	112.7	37"		78.4	72.5
42"		150.0	150.0	42"		107.4	99.3	42"		69.1	63.8
48"		150.0	149.0	48"		94.0	86.9	48"		60.4	55.9
54"		143.2	132.4	54"		83.6	77.2	54"		53.7	49.7
60"		128.9	119.2	60"		75.2	69.5	60"		48.3	44.7
66"	117.2	108.3	66"	68.4	63.2	66"	43.9	40.6			
72"	107.4	99.3	72"	62.7	57.9	72"	40.3	37.2			
19-1/8"	74-1/4"	150.0	150.0	19-1/8"	120"	150.0	150.0	19-1/8"	180"	150.0	140.2
26-1/2"		150.0	150.0	26-1/2"		150.0	141.6	26-1/2"		109.5	101.2
30"		150.0	150.0	30"		135.4	125.1	30"		96.7	89.4
37"		150.0	150.0	37"		109.8	101.4	37"		78.4	72.5
42"		150.0	144.4	42"		96.7	89.4	42"		69.1	63.8
48"		136.7	126.4	48"		84.6	78.2	48"		60.4	55.9
54"		121.5	112.3	54"		75.2	69.5	54"		53.7	49.7
60"		109.4	101.1	60"		67.7	62.6	60"		48.3	44.7
66"	99.4	91.9	66"	61.5	56.9	66"	43.9	40.6			
72"	91.2	84.3	72"	56.4	52.1	72"	40.3	37.2			
19-1/8"	76"	150.0	150.0	19-1/8"	132"	150.0	150.0	19-1/8"	192"	150.0	140.2
26-1/2"		150.0	150.0	26-1/2"		139.3	128.8	26-1/2"		109.5	101.2
30"		150.0	150.0	30"		123.1	113.7	30"		96.7	89.4
37"		150.0	150.0	37"		99.8	92.2	37"		78.4	72.5
42"		150.0	141.1	42"		87.9	81.2	42"		69.1	63.8
48"		133.6	123.5	48"		76.9	71.1	48"		60.4	55.9
54"		118.7	109.8	54"		68.4	63.2	54"		53.7	49.7
60"		106.9	98.8	60"		61.5	56.9	60"		48.3	44.7
66"	97.1	89.8	66"	55.9	51.7	66"	43.9	40.6			
72"	89.1	82.3	72"	51.3	47.4	72"	40.3	37.2			

ALL LOADS ARE EXT.(+)/INT.(-).

TYPICAL ANCHORS AT 'F' CLIP:

1/4" DIA. ULTRACON+ BY 'DEWALT' (Fu=164 KSI, Fy=148 KSI)

C4F: DIRECTLY INTO CONCRETE
1-3/4" MIN. EMBED INTO CONCRETE

#14 SMS OR SELF-DRILLING SCREWS (GRADE 2 CRS)

M4F: INTO METAL STRUCTURES
(3) THREADS MIN. TO EXTEND BEYOND METAL THICKNESS
ALUMINUM: 1/8" THK. MIN. (6063-T5 MIN.)
STEEL: 1/8" THK. MIN. (Fy = 36 KSI MIN.)
(STEEL IN CONTACT WITH ALUMINUM TO BE PLATED OR PAINTED)

TYPICAL EDGE DISTANCE

INTO CONCRETE = 2-1/2" MIN.
INTO METAL STRUCTURE = 3/4" MIN.

CONCRETE AT HEAD, SILL OR JAMBS f'c = 3000 PSI MIN.

ANCHORS MAY BE HEX OR FLAT HEAD

NOTE:
ANY ANCHOR CONDITION SHOWN HEREIN MAY COVER LOCATIONS
AT HEAD, SILL OR JAMB ENDS.
SEE SHEET 15 FOR ANCHOR DETAILS.

(INTERPOLATION BETWEEN WIDTHS OR SPANS ALLOWED)

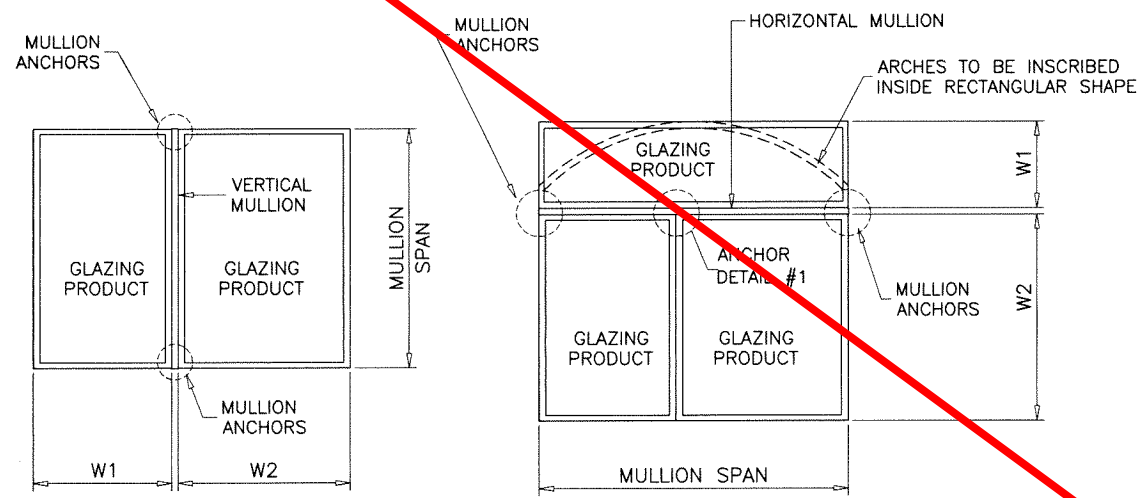

TYPICAL MULLION ARRANGEMENTS

$$\text{WIDTH (W)} = \frac{W1 + W2}{2}$$

Sealed: 7/21/2023

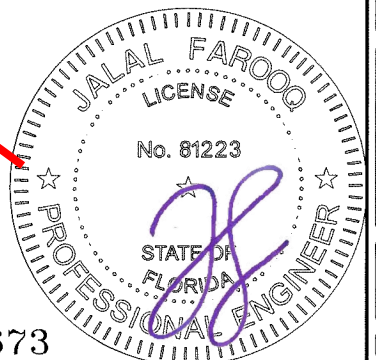

FL #40673

af c
AL-FAROOQ CORPORATION
ENGINEERS & PRODUCT DEVELOPMENT
9360 SUNSET DRIVE, SUITE 220
MIAMI, FLORIDA 33173
WWW.AFCENG.COM
TEL. (305) 264-8100
FBPE #3598

EXTRUDED ALUMINUM CLIPPED MULLIONS
MR-GLASS DOORS & WINDOWS MANUFACTURING, LLC
8051 N.W. 79th Place
Medley, FL 33166
Tel. (305) 764-3963
www.mrglasswindows.com

revisions:	no	date	by	description
date:	12-21-21	scale:	-	dr. by: TARIQ
chk. by:				

drawing no.
21-75F
sheet 16.1 of 17

DESIGN LOAD CAPACITY - PSF				DESIGN LOAD CAPACITY - PSF				DESIGN LOAD CAPACITY - PSF			
WINDOW DIMS.		ANCHORS TYPE		WINDOW DIMS.		ANCHORS TYPE		WINDOW DIMS.		ANCHORS TYPE	
WIDTH (W)	MULL SPAN	M2A	M3A	WIDTH (W)	MULL SPAN	M2A	M3A	WIDTH (W)	MULL SPAN	M2A	M3A
19-1/8"	38-3/8"	150.0	150.0	19-1/8"	84"	150.0	150.0	19-1/8"	144"	93.7	140.5
26-1/2"		150.0	150.0	26-1/2"		115.9	150.0	26-1/2"		67.6	101.4
30"		150.0	150.0	30"		102.4	150.0	30"		59.7	89.6
37"		150.0	150.0	37"		83.0	124.5	37"		48.4	72.6
42"		150.0	150.0	42"		73.1	109.7	42"		42.7	64.0
48"		140.1	150.0	48"		64.0	96.0	48"		37.3	56.0
54"		124.5	150.0	54"		56.9	85.3	54"		33.2	49.8
60"		112.1	150.0	60"		51.2	76.8	60"		29.9	44.8
66"		101.9	150.0	66"		46.5	69.8	66"		27.2	40.7
72"		93.4	140.1	72"		42.7	64.0	72"		24.9	37.3
19-1/8"	50-5/8"	150.0	150.0	19-1/8"	96"	140.5	150.0	19-1/8"	156"	86.5	129.7
26-1/2"		150.0	150.0	26-1/2"		101.4	150.0	26-1/2"		62.4	93.6
30"		150.0	150.0	30"		89.6	134.4	30"		55.1	82.7
37"		137.8	150.0	37"		72.6	109.0	37"		44.7	67.1
42"		121.4	150.0	42"		64.0	96.0	42"		39.4	59.1
48"		106.2	150.0	48"		56.0	84.0	48"		34.5	51.7
54"		94.4	141.6	54"		49.8	74.7	54"		30.6	45.9
60"		85.0	127.4	60"		44.8	67.2	60"		27.6	41.4
66"		77.2	115.8	66"		40.7	61.1	66"		25.1	37.6
72"		70.8	106.2	72"		37.3	56.0	72"		23.0	34.5
19-1/8"	63"	150.0	150.0	19-1/8"	108"	124.9	150.0	19-1/8"	168"	80.3	120.5
26-1/2"		150.0	150.0	26-1/2"		90.2	135.2	26-1/2"		58.0	86.9
30"		136.5	150.0	30"		79.6	119.5	30"		51.2	76.8
37"		110.7	150.0	37"		64.6	96.9	37"		41.5	62.3
42"		97.5	146.3	42"		56.9	85.3	42"		36.6	51.9
48"		85.3	128.0	48"		49.8	74.7	48"		32.0	48.0
54"		75.9	113.8	54"		44.2	66.4	54"		28.4	42.7
60"		68.3	102.4	60"		39.8	59.7	60"		25.6	38.4
66"		62.1	93.1	66"		36.2	54.3	66"		23.3	34.5
72"		56.9	85.3	72"		33.2	49.8	72"		21.3	32.0
19-1/8"	74-1/4"	150.0	150.0	19-1/8"	120"	112.4	150.0	19-1/8"	180"	74.2	114.5
26-1/2"		131.1	150.0	26-1/2"		81.1	121.7	26-1/2"		54.2	81.9
30"		115.8	150.0	30"		71.7	107.5	30"		47.2	71.9
37"		93.9	140.9	37"		58.1	87.2	37"		41.5	62.3
42"		82.7	124.1	42"		51.2	76.8	42"		36.6	51.9
48"		72.4	108.6	48"		44.8	67.2	48"		32.0	48.0
54"		64.4	96.5	54"		39.8	59.7	54"		28.4	42.7
60"		57.9	86.9	60"		35.8	53.8	60"		25.6	38.4
66"		52.7	79.0	66"		32.6	48.9	66"		23.3	34.5
72"		48.3	72.4	72"		29.9	44.8	72"		21.3	32.0
19-1/8"	76"	150.0	150.0	19-1/8"	132"	102.2	150.0	19-1/8"	192"	74.2	114.5
26-1/2"		128.1	150.0	26-1/2"		73.8	110.7	26-1/2"		54.2	81.9
30"		113.2	150.0	30"		65.2	97.7	30"		47.2	71.9
37"		91.8	137.7	37"		52.8	79.3	37"		41.5	62.3
42"		80.8	121.3	42"		46.5	69.8	42"		36.6	51.9
48"		70.7	106.1	48"		40.7	61.1	48"		32.0	48.0
54"		62.9	94.3	54"		36.2	54.3	54"		28.4	42.7
60"		56.6	84.9	60"		32.6	48.9	60"		25.6	38.4
66"		51.4	77.2	66"		29.6	44.4	66"		23.3	34.5
72"		47.2	70.7	72"		27.2	40.7	72"		21.3	32.0

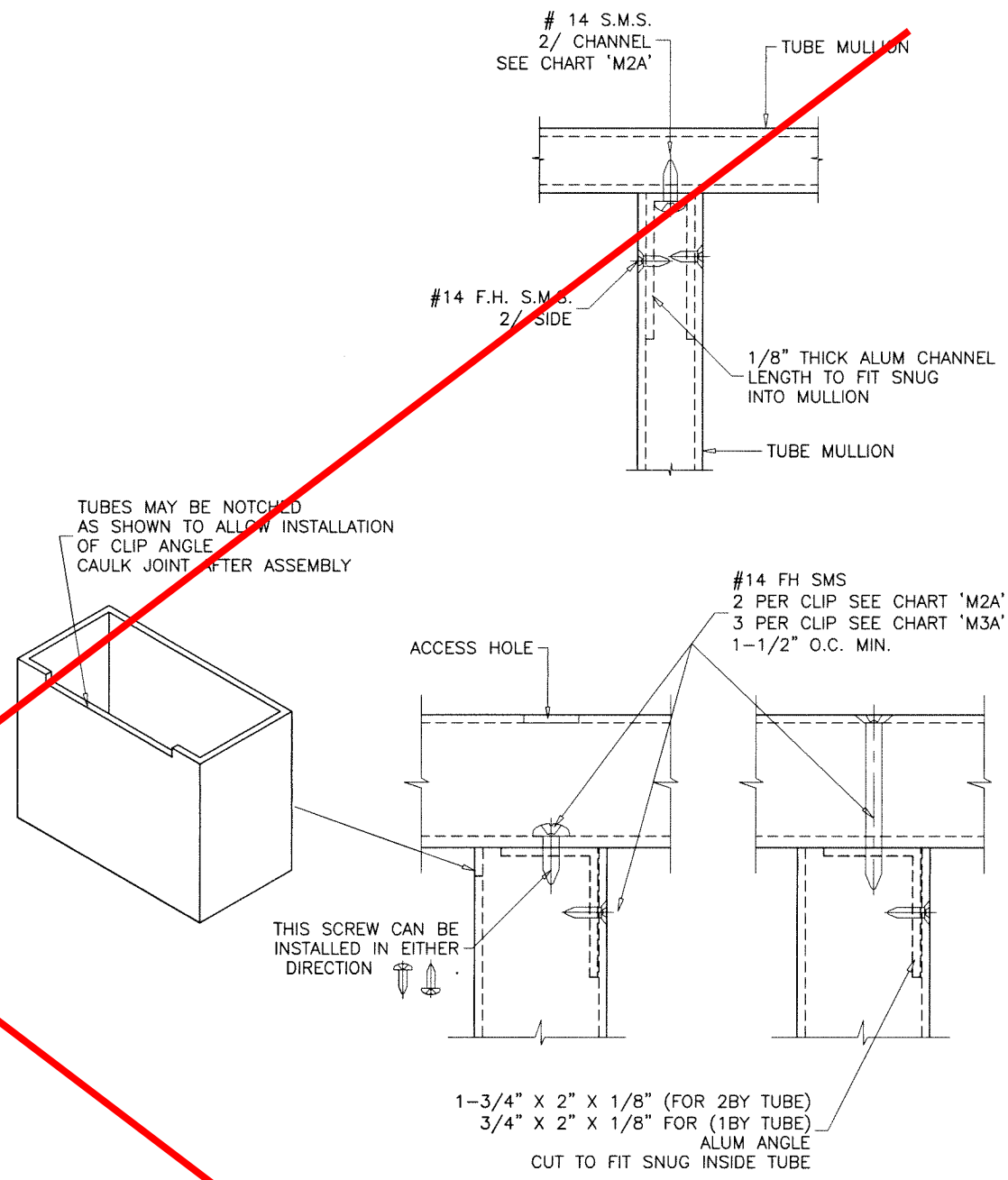

ANCHOR DETAIL #1
METAL TO METAL CONNECTION

Sealed: 7/21/2023

FL #40673

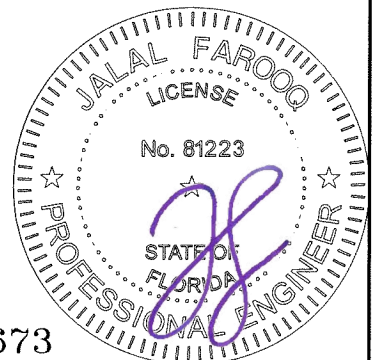

afc
AL-FAROOQ CORPORATION
 ENGINEERS & PRODUCT DEVELOPMENT
 9360 SUNSET DRIVE, SUITE 220
 MIAMI, FLORIDA 33173
 TEL. (305) 264-8100 WWW.AFCENG.COM
 FBPE #3558
 MULLION 21-75F-MG

EXTRUDED ALUMINUM CLIPPED MULLIONS
MR-GLASS DOORS & WINDOWS MANUFACTURING, LLC
 8051 N.W. 79th Place
 Medley, FL 33166
 Tel. (305) 764-3963
 www.mrglasswindows.com

revisions:	no	date	by	description
date:	12-21-21	scale:	3/8" = 1"	
dr. by:	TARIQ	chk. by:		
drawing no.	21-75F			
sheet	17 of 17			